

July 12, 2019

Estratto da “Lectures on Differential Topology”

Riccardo Benedetti

Author address:

DIPARTIMENTO DI MATEMATICA, UNIVERSITÀ DI PISA LARGO BRUNO PON-
TECORVO 5, 56127, PISA, ITALIA

E-mail address: `riccardo.benedetti@unipi.it`

Contents

| | |
|--|----|
| Preface | 9 |
| Chapter 1. The smooth category of open subsets of euclidean spaces | 11 |
| 1.1. Basic structures on \mathbb{R}^n | 11 |
| 1.2. Differential calculus | 13 |
| 1.3. The category of open subsets of euclidean spaces and smooth maps | 14 |
| 1.4. The chain rule and the tangent functor | 15 |
| 1.5. Tangent vector fields, riemannian metrics, gradient fields | 16 |
| 1.6. Inverse function theorem and applications | 17 |
| 1.7. Topologies on spaces of smooth maps | 21 |
| 1.8. Stability of summersions and immersions at a compact set | 22 |
| 1.9. An elementary division theorem | 22 |
| 1.10. A differential interpretation of the tangent spaces: derivations | 23 |
| 1.11. Morse lemma | 24 |
| 1.12. Bump functions and partitions of unity | 27 |
| 1.13. Homotopy, isotopy, diffeotopy | 29 |
| 1.14. Linearization of diffeomorphisms of \mathbb{R}^n up to isotopy | 30 |
| 1.15. Homogeneity | 30 |
| Chapter 2. The category of embedded smooth manifolds | 33 |
| 2.1. Basic properties and examples | 33 |
| 2.2. The embedded tangent functor | 36 |
| 2.3. Immersions, summersions, embeddings, Monge charts | 39 |
| 2.4. Topologies on spaces of smooth maps | 40 |
| 2.5. Homotopy, isotopy, diffeotopy, homogeneity | 41 |
| 2.6. Embedded fibre bundles | 41 |
| 2.7. Tensor functors | 42 |
| 2.8. Tensor fields, unitary tensor bundles | 44 |
| 2.9. Parallelizable, combable and orientable manifolds | 46 |
| 2.10. Manifolds with boundary, oriented boundary, proper submanifolds | 49 |
| 2.11. Product, manifolds with corners, smoothing | 51 |
| Chapter 3. Stiefel and Grassmann manifolds | 55 |
| 3.1. Stiefel manifolds | 55 |
| 3.2. Fibrations of Stiefel manifolds by Stiefel manifolds | 56 |
| 3.3. Grassmann manifolds | 58 |
| 3.4. Stiefel manifolds as fibre bundles over Grassmann manifolds | 59 |
| 3.5. A cellular decomposition of the Grassmann manifolds | 61 |
| 3.6. Stiefel and Grassmannian manifolds as regular real algebraic sets | 63 |
| Chapter 4. Tautological bundles and pull-back | 65 |
| 4.1. Tautological bundles | 65 |
| 4.2. Pull-back | 66 |
| 4.3. Categories of vector bundles | 68 |
| 4.4. The frame bundles | 69 |

| | | |
|-------------|---|-----|
| 4.5. | Limit tautological bundles | 70 |
| 4.6. | A classification theorem for compact manifolds | 71 |
| 4.7. | The rings of stable equivalence classes of vector bundles | 73 |
| Chapter 5. | Compact embedded smooth manifolds | 79 |
| 5.1. | Nice atlas and finite partitions of unity | 79 |
| 5.2. | Spaces of maps with compact source manifold | 80 |
| 5.3. | Tubular neighbourhoods and collars | 81 |
| 5.4. | Proper embedding and “double” of manifolds with boundary | 84 |
| 5.5. | A fibration theorem | 86 |
| 5.6. | Density of smooth among C^r -maps | 86 |
| 5.7. | Smooth homotopy groups - Vector bundles on spheres | 87 |
| 5.8. | Smooth approximation of compact embedded C^r -manifolds | 87 |
| 5.9. | Nash approximation of compact embedded smooth manifolds | 89 |
| 5.10. | Smooth and Nash Sard-Brown theorem | 91 |
| 5.11. | Morse functions via generic linear projections to lines | 93 |
| 5.12. | Morse functions via distance functions | 96 |
| 5.13. | Generic linear projections to hyperplanes | 97 |
| Chapter 6. | The category of smooth manifolds | 99 |
| 6.1. | The (abstract) tangent functor | 103 |
| 6.2. | Principal and associated bundles with given structural group | 105 |
| 6.3. | Embedding abstract compact manifolds | 106 |
| 6.4. | On complex manifolds | 108 |
| Chapter 7. | Cut and paste compact manifolds | 109 |
| 7.1. | Extension of isotopies to diffeotopies | 109 |
| 7.2. | Gluing manifolds together along boundary components | 111 |
| 7.3. | On corner smoothing | 113 |
| 7.4. | Uniqueness of smooth disks up to diffeotopy | 113 |
| 7.5. | Connected sum, shelling | 114 |
| 7.6. | Attaching handles | 117 |
| 7.7. | Strong embedding theorem, the Whitney Trick | 118 |
| 7.8. | On immersions of n -manifolds in \mathbb{R}^{2n-1} | 121 |
| 7.9. | Embedding n -manifolds in \mathbb{R}^{2n-1} up to surgery | 122 |
| 7.10. | Projectivized vector bundles and blowing up | 124 |
| Chapter 8. | Transversality | 129 |
| 8.1. | Basic transversality | 129 |
| 8.2. | Miscellaneous transversalities | 133 |
| Chapter 9. | Morse functions and handle decompositions | 139 |
| 9.1. | Dissections carried by generic Morse functions | 140 |
| 9.2. | Handle decompositions | 143 |
| 9.3. | Moves on handle decompositions | 144 |
| 9.4. | Compact 1-manifolds | 147 |
| Chapter 10. | Bordism | 149 |
| 10.1. | The bordism modules of a topological space | 149 |
| 10.2. | Bordism covariant functors | 151 |
| 10.3. | Relative bordism of topological pairs | 151 |
| 10.4. | On Eilenberg-Steenrod axioms | 152 |
| 10.5. | Bordism non triviality | 155 |
| 10.6. | Relation between bordism and homotopy group functors | 156 |
| 10.7. | Bordism categories | 158 |
| 10.8. | A glance to TQFT | 158 |

| | |
|--|-----|
| Chapter 11. Smooth cobordism | 161 |
| 11.1. Map transversality | 161 |
| 11.2. Cobordism contravariant functors | 162 |
| 11.3. The cobordism cup product | 164 |
| 11.4. Duality, intersection forms | 166 |
| 11.5. Cobordism theory for compact manifolds with boundary | 168 |
| Chapter 12. Applications of cobordism rings | 171 |
| 12.1. Fundamental class revised, Brouwer's fixed point Theorem | 171 |
| 12.2. A separation theorem | 171 |
| 12.3. Intersection numbers | 172 |
| 12.4. Linking numbers | 172 |
| 12.5. Degree | 173 |
| 12.6. The Euler class of a vector bundle | 175 |
| 12.7. Borsuk-Ulam theorem | 177 |
| Chapter 13. Line bundles, hypersurfaces and cobordism | 181 |
| 13.1. Real line bundles and hypersurfaces | 181 |
| 13.2. Real line bundles and $\text{Rep}(\pi_1, \mathbb{Z}/2\mathbb{Z})$ | 182 |
| 13.3. Oriented hypersurfaces and Ω^1 | 183 |
| 13.4. Complex line bundles and Ω^2 | 185 |
| 13.5. Seifert's surfaces | 186 |
| Chapter 14. Euler-Poincaré characteristic | 189 |
| 14.1. E-P characteristic via Morse functions | 189 |
| 14.2. The index of an isolated zero of a tangent vector field | 190 |
| 14.3. Index theorem | 191 |
| 14.4. E-P characteristic for non oriented manifolds | 191 |
| 14.5. Some examples and properties of χ | 192 |
| 14.6. The relative E-P characteristic of a triad, χ -additivity | 193 |
| 14.7. E-P characteristic of tubular neighbourhoods and the Gauss map | 194 |
| 14.8. Non triviality of η_\bullet and Ω_\bullet | 195 |
| 14.9. Combinatorial E-P characteristic | 196 |
| Chapter 15. Surfaces | 199 |
| 15.1. Classification of symmetric bilinear forms on $\mathbb{Z}/2\mathbb{Z}$ | 202 |
| 15.2. Classification of compact surfaces | 203 |
| 15.3. $\Omega_1(X)$ as the abelianization of the fundamental group | 206 |
| 15.4. Ω_2 and η_2 | 207 |
| 15.5. Stable equivalence - Rational models (2D Nash's conjecture) | 208 |
| 15.6. Quadratic enhancement of surface intersection forms | 209 |
| Chapter 16. Bordism characteristic numbers | 215 |
| 16.1. Stable η -numbers | 216 |
| 16.2. Completeness of stable η -numbers | 217 |
| 16.3. On Ω -characteristic numbers | 220 |
| Chapter 17. The Pontryagin-Thom construction | 223 |
| 17.1. Embedded and framed bordism | 223 |
| 17.2. The Pontryagin map | 225 |
| 17.3. Characterization of combable manifolds | 228 |
| 17.4. On (stable) homotopy groups of spheres | 228 |
| 17.5. Thom's spaces | 234 |
| Chapter 18. High dimensional manifolds | 239 |
| 18.1. On the h -cobordism theorem | 239 |

| | |
|--|-----|
| 18.2. Whitney trick and unlinking spheres into a sphere | 242 |
| Chapter 19. On 3-manifolds | 247 |
| 19.1. Heegaard splitting | 247 |
| 19.2. Surgery equivalence | 253 |
| 19.3. Proofs of $\Omega_3 = 0$ | 254 |
| 19.4. Proofs of Lickorish-Wallace theorem | 255 |
| 19.5. On $\eta_3 = 0$. | 258 |
| 19.6. Combing and framing | 259 |
| 19.7. What is the simplest proof that $\Omega_3 = 0$? | 271 |
| 19.8. The bordism group of immersed surfaces into a 3-manifold | 271 |
| 19.9. Tear and smooth-rational equivalences | 285 |
| Chapter 20. On 4-manifolds | 297 |
| 20.1. Symmetric unimodular \mathbb{Z} -bilinear forms | 297 |
| 20.2. Some 4-manifold counterparts | 301 |
| 20.3. Ω_4 | 305 |
| 20.4. Simply connected classification up to odd stabilization | 307 |
| 20.5. On the classification up to even stabilization | 308 |
| 20.6. Congruences modulo 16 | 309 |
| 20.7. On the topological classification of smooth 4-manifolds | 316 |
| Chapter 21. Appendix: baby categories | 319 |
| Bibliography | 321 |

Preface

Along the years I have taught several times courses of differential topology for the master curriculum in Mathematics at the University of Pisa. Typically the class was attended by students who had accomplished (or were accomplishing) a first three years curriculum in mathematics, together with a few peer physicists and a few beginner PhD students. With the constraints imposed by their presumable knowledges, time after time a certain body of topics, in different combinations, as well as a certain way to present them stabilized. This textbook summarizes such teaching experiences, so it keeps a character of “lecture notes” rather than of a comprehensive and systematic treatise. It happens in a class to prefer a shortcut towards some interesting application, giving up the largest generality. Similarly in this text, for example, we will mainly focus on *compact* manifolds (especially when we consider the sources of smooth maps). This allows simplifications in dealing for instance with *function spaces* or with certain “globalization procedures” of maps. There is already a plenty of interesting facts concerning compact manifolds, so we will do it without remorse.

There is a lot of classical wellknown references (like [M1], [GP], [H], [M2], [M3], [Mu], . . .) which I used in preparing the courses and have strongly influenced these pages. So, why a further textbook on differential topology? An important motivation came to me by looking at the personal polished notes of a few good students glimpsing the lines of a reasonable text, together with the remark made by someone of them that “they had not been able to find anywhere some of the topics treated in the course”. It would be very hard to claim any ‘originality’ in dealing with such a classical matter. However, the last sentence has perhaps a grain of truth, at least referring to textbooks mainly addressed to undergraduate readers. Let us indicate a main example. A theme of this text (alike others) is the synergy between *bordism* and *transversality*. One of the beforehand mentioned constraints is that we cannot assume any familiarity with algebraic topology or homological algebra (besides perhaps the very basic facts about homotopy groups); on another hand, it is very useful and meaningful to dispose of a (co)-homology theory suited to embody several differential topology constructions. We will show that (oriented or non oriented) bordism provides instances of covariant so called “generalized” homology theories for arbitrary pairs (X, A) of topological spaces, constructed via geometric means. Then, by restricting to compact smooth manifolds X , and after a reindexing of the bordism modules by the *codimension* (so that they are now called cobordism modules), transversality allows to incorporate the bordism modules into a *contravariant cobordism functor* with as target the category of *graded rings*; also the product on cobordism modules is defined by direct geometric means. This multiplicative structure is a substantial enrichment and will lead to several important and often very classical applications. For example it is the natural contest for unavoidable topics like the degree theory or the Poincaré-Hopf index theorem. Once the cobordism product has been well-defined, we are exempted from reproving it case by case for each specialization/application; moreover, the emphasis is on the “invariance up to bordism” rather than on the “invariance up to homotopy” as it

happens for most established references. Not assuming any familiarity with algebraic topology, this presentation could also be useful as an intuitive, geometrically based introduction to some themes of that discipline.

Overall this text, besides the very foundation topics, is a collection of themes - whose choice certainly is also matter of personal preference - in some case advanced and of historical importance, with the common feature that they can be treated by “*bare hands*”. This means by just combining specific differential-topological cut-and-paste procedures and applications of transversality, mainly through the cobordism multiplicative structure. This geometric constructive character provides the ‘tone’ of this text, would be accessible to motivated master undergraduate students, to PhD students and also useful to a more expert reader in order to recognize very basic reasons for some facts already known to her/him as resulting from more advanced theories and/or technologies.

Dedico tutto questo ai miei nipoti Pietro(lino) e Martin(in)a

Riccardo Benedetti

Sassetta XX/XX/XXXX

The smooth category of open subsets of euclidean spaces

We will be concerned with manifolds. Roughly, a manifold is a topological space locally modeled on some euclidean space \mathbb{R}^n , $n \in \mathbb{N}$. So let us recall a few facts about our favourite local models. Many of them should be familiar to the readers, so sometimes we will omit the proofs or just sketch them.

1.1. Basic structures on \mathbb{R}^n

Every space \mathbb{R}^n , $n \in \mathbb{N}$, is endowed with a variety of structures that case by case will be involved in the discussion.

\mathbb{R}^n is the *vector space* of columns vectors (with n rows). We stipulate that if $x \in \mathbb{R}^n$ occurs as a vector in any linear algebra formula then it is considered as a column.

The space $\mathcal{L}(\mathbb{R}^n, \mathbb{R}^m)$ of linear maps $L : \mathbb{R}^n \rightarrow \mathbb{R}^m$ coincides with the space of matrices $m \times n$, $M(m, n, \mathbb{R})$, so that for every $x \in \mathbb{R}^n$, $x \rightarrow Lx$ via the usual “lines by column” product. By using the lexicographic order on the entries of any matrix $L = (l_{i,j})_{i=1,\dots,m;j=1,\dots,n}$, we fix also the identification of $M(m, n, \mathbb{R})$ with \mathbb{R}^{mn} . As every vector space, \mathbb{R}^n has a canonical *affine space* structure determined by the map that associates to every couple of points $(x, y) \in \mathbb{R}^n \times \mathbb{R}^n$ the vector $\vec{xy} := y - x$. Every *affine map* $f : \mathbb{R}^n \rightarrow \mathbb{R}^m$ is of the form $f(x) = w + Lx$ where $w \in \mathbb{R}^m$ and $L \in \mathcal{L}(\mathbb{R}^n, \mathbb{R}^m)$.

\mathbb{R}^n is a *complete metric space* endowed with the *euclidean distance* $d = d_n$ defined by

$$d(x, y) = \sqrt{\sum_{j=1}^n (x_j - y_j)^2}.$$

The *standard positive definite scalar product* $(*, *) = (*, *)_n$ on \mathbb{R}^n is defined by

$$(x, y) := \sum_{j=1}^n x_j y_j = x^t I y$$

with the associated *norm* $\|x\| = \sqrt{(x, x)}$. We note that

$$d^2(x, y) = (x - y, x - y)$$

and that the familiar formula

$$(x, y) = \|x\| \cdot \|y\| \cos \theta$$

allows to recover the measure of the angle formed by the ordered and oriented lines spanned by two non zero vectors x, y ; in particular they are orthogonal iff $(x, y) = 0$. Hence many basic objects of elementary geometry can be expressed analytically by means of the standard scalar product.

\mathbb{R}^n is a *topological space* endowed with the topology $\tau = \tau_n$ induced by the distance d_n . As for any metrizable topological space, a subset U of \mathbb{R}^n is *open* if

and only if for every $x \in U$, there is $r > 0$ such that the “open” n -ball of center x and radius r

$$B^n(x, r) := \{y \in \mathbb{R}^n; d(x, y) < r\}$$

is contained in U . We will denote by

$$D^n = \overline{B}^n(0, 1)$$

the *closed unitary n -ball* also called the *unitary n -disk*, and by

$$S^{n-1} = \partial D^n = \{x \in \mathbb{R}^n; d(0, x) = \|x\| = 1\}$$

the *unitary sphere*. One verifies that the “open” balls are indeed open sets and the open balls with center in $\mathbb{Q}^n \subset \mathbb{R}^n$ and rational radius form a *countable basis of open sets of τ* (every open set is union of such balls). Any other scalar product

$$(x, y)_A := x^t A y$$

defined by a positive definite symmetric matrix $A = A^t$, determines (by the same formulas as above) a norm $\|\cdot\|_A$, a distance d_A and an associated topology τ_A . In fact all these distances are *topologically equivalent*, that is every $\tau_A = \tau$. This can be proved by means of the version of elementary *spectral theorem* stating that there exists a basis of \mathbb{R}^n which is simultaneously orthonormal for $(*, *)$ and orthogonal for $(*, *)_A$. Another topologically equivalent distance on \mathbb{R}^n is defined by

$$\delta(x, y) := \max\{|x_j - y_j|; j = 1, \dots, n\}.$$

Accordingly to general topological definitions, for every $X \subset \mathbb{R}^n$,

$$\tau \cap X = \{U \cap X; U \in \tau\}$$

is the topology on X that makes it a *topological subspace* of (\mathbb{R}^n, τ) ; given subspaces $X \subset \mathbb{R}^n$, $Y \subset \mathbb{R}^m$, a map $f : X \rightarrow Y$ is *continuous* if for every open set $U \subset Y$, the *inverse image* $f^{-1}(U) = \{x \in X; f(x) \in U\}$ is an open set of X . A continuous map $f : X \rightarrow Y$ is a *homeomorphism* if it is bijective and also the *inverse map* $f^{-1} : Y \rightarrow X$ is continuous.

Every subspace $X \subset \mathbb{R}^n$ is metrizable (hence in particular *Hausdorff*) by the restriction to X of the distance d (or of any distance topologically equivalent to d); the restriction of any (countable) basis of open sets of τ is a (countable) basis of $\tau \cap X$.

As for every Hausdorff space with a countable basis, a subspace X of \mathbb{R}^n is *compact* (i.e. every open covering of X admits a *finite* sub-covering) if and only if it is *sequentially compact* (i.e. every sequence a_n of points of X admits a subsequence a_{j_n} converging to some point x of X). A subspace is compact if and only if it is *closed* (i.e. the complementary is open) and *bounded* (i.e. it is contained in some ball $B^n(0, r)$). \mathbb{R}^n is *locally compact* (for every $x \in \mathbb{R}^n$ the family of *closed balls* $\overline{B}^n(x, r) = \{y \in \mathbb{R}^n; d(x, y) \leq r\}$, when $r > 0$ varies, is a basis of compact neighbourhoods of x). The same holds for every subspace X which is a closed subset of \mathbb{R}^n .

We have

PROPOSITION 1.1. *A non empty open subset $U \subset \mathbb{R}^n$ is connected (i.e. U is the only open-and-closed non empty subset of U) if and only if it is path connected (i.e. for every two points x_0, x_1 of U , there is a continuous path $\alpha : [0, 1] \rightarrow U$ such that $\alpha(0) = x_0, \alpha(1) = x_1$).*

Proof : The “if” implication holds in general for arbitrary topological spaces and is due to the basic fact that intervals in the real line are connected; for “only if”, note that “being connected by a continuous path” defines an equivalence relation on U . The equivalence classes are called the *path connected components* of U . As every open ball $B^n(x, r) \subset U$ is contained in the path connected component of U

which contains $x \in U$, then every path connected component of U is open, hence there is only one if U is connected. \square

1.2. Differential calculus

Another fundamental structure carried by the spaces \mathbb{R}^n is the *differential calculus*. Let $U \subset \mathbb{R}^n$, $W \subset \mathbb{R}^m$ be open sets. A map

$$f = (f_1, \dots, f_m) : U \rightarrow W$$

is said to be \mathcal{C}^0 if it is continuous. The map is *differentiable* at $x \in U$ if there is a (necessarily unique) linear map $d_x f \in \mathcal{L}(\mathbb{R}^n, \mathbb{R}^m)$ that “well” approximates $g(h) = f(x+h) - f(x)$ in a neighbourhood of $h = 0$. Precisely, for every $\epsilon > 0$, there is $\delta > 0$ such that for every h such that $\|h\| < \delta$, $x+h \in U$ and

$$\|g(h) - d_x f(h)\| \leq \epsilon \|h\| .$$

The linear map $d_x f$ is called the *differential of f at x* . The map f is (globally) *differentiable* if it is differentiable at every point $x \in U$. In such a case it is defined the *differential map*

$$df : U \rightarrow M(m, n, \mathbb{R}), \quad df(x) := d_x f .$$

We say that f is \mathcal{C}^1 if it is differentiable and df is continuous (being $\mathcal{L}(\mathbb{R}^n, \mathbb{R}^m) = M(m, n, \mathbb{R})$ confused with \mathbb{R}^{mn} as above). Every \mathcal{C}^1 map is \mathcal{C}^0 . By induction, for every $r \geq 1$, we say that f is \mathcal{C}^r if df is \mathcal{C}^{r-1} . In practice, f is \mathcal{C}^r , $r \geq 1$, if and only if it is \mathcal{C}^0 and for every multi-index $J = j_1 \dots j_n$ of order $|J| := j_1 + \dots + j_n \leq r$, for every $i = 1, \dots, m$, it is defined and is continuous the *partial derivative function*

$$\frac{\partial^J f_i}{\partial^{j_1} x_1 \dots \partial^{j_n} x_n} : U \rightarrow \mathbb{R} .$$

Then for every $x \in U$, the partial derivatives of the first order can be organized in a $m \times n$ matrix so that

$$d_x f := \left(\frac{\partial f_i}{\partial x_j}(x) \right)_{i=1, \dots, m; j=1, \dots, n} \in M(m, n, \mathbb{R}) .$$

This is a consequence of the “chain rule” (see below).

A map f is \mathcal{C}^∞ or, equivalently, *smooth* if it is \mathcal{C}^r for every $r \geq 0$. If f is smooth, then also df is smooth. So we can define inductively for every $r \geq 1$, $d^r f = d(d^{r-1} f)$.

If f is (at least) \mathcal{C}^1 we have the following *uniform* version of the above property that define the differentials $d_x f$: for every $x \in U$ there exists a neighbourhood W of x in U (we can take as W a compact closed ball $\bar{B}^n(x, \rho) \subset U$), such that for every $\epsilon > 0$, there is $\delta > 0$ such that for every $y \in W$ and for every h , $\|h\| < \delta$ we have $y+h \in U$ and

$$\|f(y+h) - f(y) - d_y f(h)\| \leq \epsilon \delta ;$$

in other words

$$\lim_{h \rightarrow 0} \frac{g(y, h) - d_y f(h)}{\|h\|} = 0 .$$

uniformly with respect to $y \in W$.

From now on we will be mainly concerned with smooth maps.

(Taylor polynomials.) A *homogeneous polynomial maps of degree $k \geq 1$*

$$\mathbf{p} : \mathbb{R}^n \rightarrow \mathbb{R}^m$$

is by definition of the form $\mathbf{p}(x) = \phi(x, \dots, x)$, where $\phi : (\mathbb{R}^n)^k \rightarrow \mathbb{R}^m$ is a (necessarily unique) *symmetric k -linear map* (ϕ is called the “polarization” of \mathbf{p}). It follows that the set $\mathcal{P}_k(n, m)$ of these homogeneous polynomial maps has a natural

structure of finite dimensional real vector space. A *polynomial map of degree d* , $p : \mathbb{R}^n \rightarrow \mathbb{R}^m$, is of the form

$$p = p_0 + p_1 + \cdots + p_d$$

where $p_0 \in \mathbb{R}^m$ and for $j \geq 1$, p_j is homogeneous polynomial of degree j and p_d is not zero.

Let $f : \mathbb{R}^n \rightarrow \mathbb{R}^m$ be a smooth map. Then for every $k \geq 1$ there is a smooth map

$$T_k(f) : U \rightarrow \mathcal{P}_k(n, m)$$

such that for every $k \geq 1$, for every $x \in U$, there is a neighbourhood W of x in U such that for every $\epsilon > 0$, there is $\delta > 0$ such for every $y \in W$ and every h , $\|h\| < \delta$, we have $y + h \in U$ and

$$\|f(y + h) - (f(y) + T_1(f)(y)(h) + \cdots + T_k(f)(y)(h))\| \leq \epsilon \|h\|^k .$$

The maps $T_k(f)$ are uniquely determined by these conditions. Clearly

$$T_1(f)(x) = d_x f .$$

More generally, every $\mathbf{p} = (\mathbf{p}_1, \dots, \mathbf{p}_m) \in \mathcal{P}_k(n, m)$ is of the form

$$\mathbf{p}_i(h) = \sum_{|J|=k} a_i^J h_1^{j_1} \cdots h_n^{j_n}$$

where the coefficients $a_i^J \in \mathbb{R}$. Then one verifies that $T_k(f)(x)$ is uniquely determined by the formulas

$$a_i^J = \frac{1}{k!} \frac{\partial^J f_i}{\partial^{j_1} x_1 \cdots \partial^{j_n} x_n}(x) .$$

In other words, $T_k(f)(x)$ is determined by means of $\frac{1}{k!} d_x^k(f)$. $T_k(f)(x)$ is the *homogeneous degree- k Taylor polynomial of f at x* . Setting $f(x) = T_0(f)(x)$, the polynomial map (of the variable h)

$$\mathcal{T}_k(f)(x) := T_0(f)(x) + T_1(f)(x) + \cdots + T_k(f)(x)$$

is called *Taylor polynomial of f at x of degree $\leq k$* .

1.3. The category of open subsets of euclidean spaces and smooth maps

Let $f : U \rightarrow W$, $g : U' \rightarrow W'$ be smooth maps between open subsets of some (possibly variable) euclidean spaces. The composition $g \circ f$ is defined when $W \subset U'$. The fundamental well known *chain rule* for the composition of differentiable maps states that for every $x \in U$, $y = f(x)$, $g \circ f$ is differentiable at x and

$$d_x(g \circ f) = d_y g \circ d_x f .$$

It follows immediately that if f and g are smooth then also $g \circ f$ is smooth. Then we can consider the category whose *objects* are the open subsets of euclidean spaces and for every couple (U, W) of objects, the “*arrows*” (that is the *morphisms*) are the smooth maps $\mathcal{C}^\infty(U, W)$.

For every object $U \subset \mathbb{R}^n$, the unit map 1_U is the *identity*

$$\text{id}_U : U \rightarrow U, \text{id}_U(x) = x$$

which is obviously smooth. For every $x \in U$,

$$d_x \text{id}_U = \text{id}_{\mathbb{R}^n} = I_n \in \text{End}(\mathbb{R}^n) = M(n, \mathbb{R}) .$$

If $U' \subset U$ then the inclusion $i : U' \rightarrow U$ is smooth and for every $f \in \mathcal{C}^\infty(U, W)$, the *restriction* $f|_{U'} = f \circ i$ is smooth.

The *equivalences* in this category are the *diffeomorphisms*. Let $U \subset \mathbb{R}^n$ and $W \subset \mathbb{R}^m$ be open sets. Then $f \in \mathcal{C}^\infty(U, W)$ is a diffeomorphism if it is a homeomorphism and also the inverse map $f^{-1} : W \rightarrow U$ is smooth. In such a case, by applying again the chain rule, we have that for every $x \in U$, $y = f(x)$, $d_y f^{-1} \circ d_x f = I_n$,

$d_x f \circ d_y f^{-1} = I_m$, then by elementary linear algebra both inequalities $n \leq m$ and $m \leq n$ hold, so that $m = n$; finally $d_x f \in \text{GL}(n, \mathbb{R})$ is invertible and

$$d_y f^{-1} = (d_x f)^{-1} .$$

Hence we have proved the *invariance of the dimension up to diffeomorphism* and this is reduced to the basic invariance of dimension up to linear isomorphism.

Another consequence of these considerations (based on the chain rule):

If a smooth homeomorphism $f : U \rightarrow W$ has differentiable inverse map f^{-1} then it is a diffeomorphism (i.e. f^{-1} is smooth indeed).

1.4. The chain rule and the tangent functor

The chain rule can be rephrased in the language of *functors* between categories. A way is to consider the category of *pointed* open subsets of some euclidean spaces and pointed smooth maps. Then by setting

$$(U, x), U \subset \mathbb{R}^n \implies \mathbb{R}^n$$

$$f \in \mathcal{C}^\infty((U, x), (W, y)), U \subset \mathbb{R}^n, W \subset \mathbb{R}^m \implies d_x f \in \mathcal{L}(\mathbb{R}^n, \mathbb{R}^m)$$

we define a *covariant* functor from the smooth pointed category to the category of finite dimensional real vector spaces and linear maps.

Avoiding to deal with the pointed category, another way is by defining the so called *tangent functor* which is a covariant functor from our favourite category to itself. Set

$$U \subset \mathbb{R}^n \implies T(U) := U \times \mathbb{R}^n \subset \mathbb{R}^n \times \mathbb{R}^n$$

$$f \in \mathcal{C}^\infty(U, W) \implies Tf \in \mathcal{C}^\infty(T(U), T(W)), Tf(x, v) := (f(x), d_x f(v)) .$$

The chain rule can be rewritten as

$$T(g \circ f) = Tg \circ Tf$$

$$T\text{id}_U = \text{id}_{T(U)}$$

if $f \in \mathcal{C}^\infty(U, W)$ is a diffeomorphism, then also Tf is a diffeomorphism.

There is a natural projection

$$\pi_U : T(U) \rightarrow U, \pi_U(x, v) = x .$$

$(T(U), \pi_U)$ is called the *tangent bundle of U* . For every $x \in U$, the *fibre*

$$T_x U := \pi_U^{-1}(x)$$

is naturally identified with the *vector space* \mathbb{R}^n and is called the *tangent spaces to U at x* . Every $v \in T_x U$ is a tangent vector at x . This notion of $T_x U$ is essentially the one we get by considering U as an open set in the *affine* space \mathbb{R}^n .

The map Tf is called the *tangent map of f* . Clearly,

$$\pi_W \circ Tf = f \circ \pi_U$$

that is Tf sends every fibre $T_x U$ to the fibre $T_{f(x)} W$ by means of the linear map $d_x f$ which varies smoothly when x varies in U .

1.5. Tangent vector fields, riemannian metrics, gradient fields

A *tangent vector fields* on U (often we will omit to say “tangent”) is a smooth map of the form

$$X : U \rightarrow T(U), \quad X(x) = (x, v_X(x))$$

so that $\pi_U \circ X = \text{id}_U$. Such a map is also called a (smooth) *section* of the tangent bundle. Hence X selects a family (a “field”) of vectors $\{v_X(x) \in T_x U\}_{x \in U}$ which vary smoothly with the point $x \in U$. In practice X could be confused with the smooth map $v_X : U \rightarrow \mathbb{R}^n$; however, if $\phi : U \rightarrow W$ is a diffeomorphism, as a map $v = v_X$ is transported on W by the composition $v \circ \phi^{-1}$, while the vector field X is transported to $\phi_* X$ on W by the composition $T\phi \circ X$, that is for every $y = \phi(x) \in W$

$$\phi_* X(y) = (y, d_x \phi(v_X(x))) .$$

Denote by $\Gamma(T(U))$ the set of vector fields on U . For every $X, Y \in \Gamma(T(U))$, every $f \in \mathcal{C}^\infty(U, \mathbb{R})$, and every $x \in U$, set

$$X + Y(x) = (x, v_X(x) + v_Y(x)), \quad fX(x) = (x, f(x)v_X(x)) .$$

This defines on $\Gamma(T(U))$ a natural structure of *module* over the commutative ring $\mathcal{C}^\infty(U, \mathbb{R})$ which induces (by restriction to the constant functions) a structure of \mathbb{R} -vector space. Let us denote by $\mathbf{e}_i(x) = (x, e_i)$, $i = 1, \dots, n$, the *constant vector field* on U such that $e_i = (0, 0, \dots, 1, \dots, 0)^t$ is the i th-vector of the canonical basis of \mathbb{R}^n . Sometimes \mathbf{e}_i is also denoted by $\frac{\partial}{\partial x_i}$. Then for every $X \in \Gamma(T(U))$,

$$X = \sum_i v_{X,i} \mathbf{e}_i$$

that is the fields \mathbf{e}_i form a basis of such a module.

A riemannian metric on $U \subset \mathbb{R}^n$, is a smooth map

$$g : U \rightarrow M(n, \mathbb{R})$$

such that for every $x \in U$, the matrix $g(x)$ is symmetric and positive definite. Then $\{g(x)\}_{x \in U}$ is a smooth *fields of positive definite scalar products* $(*, *)_{g(x)}$ defined on each tangent space $T_x U$. Denote by $S(n, \mathbb{R})$ the space of symmetric $n \times n$ matrices ($S(n, \mathbb{R})$ can be identified with $\mathbb{R}^{\frac{n(n+1)}{2}}$). By setting

$$U \rightarrow U \times S(n, \mathbb{R}), \quad x \rightarrow (x, g(x))$$

then the riemannian metric can be interpreted as a section of the “product bundle” $U \times S(n, \mathbb{R}) \rightarrow U$.

If g is a riemannian metric on U and $X, Y \in \Gamma(T(U))$, then

$$x \rightarrow (v_X(x), v_Y(x))_{g(x)}$$

defines a smooth function on U .

If g_0 and g_1 are riemannian metrics on U , then $g_t = (1-t)g_0 + tg_1$, $t \in [0, 1]$, is a path of riemannian metrics.

An *isometry* $\phi : (U, g) \rightarrow (W, h)$ (g, h being riemannian metrics) is by definition a diffeomorphism such that for every $x \in U$, every $v, w \in T_x U$,

$$(v, w)_{g(x)} = (d_x \phi(v), d_x \phi(w))_{h(\phi(x))} .$$

Given (U, g) and a diffeomorphism $\phi : U \rightarrow W$, this transports g to the riemannian metric $\phi_* g$ on W such that ϕ is *tautologically* an isometry. If $y \in W$, set $P(y) = d_y \phi^{-1}$, then

$$\phi_* g : W \rightarrow M(n, \mathbb{R}), \quad y \rightarrow P(y)^t g(\phi^{-1}(y)) P(y) .$$

If $f \in \mathcal{C}^\infty(U, \mathbb{R})$, its differential function $df : U \rightarrow M(1, n)$ can be considered as a smooth *field of linear functionals* $\{d_x f : T_x U \rightarrow \mathbb{R}\}_{x \in U}$, $d_x f$ belonging to the

dual space T_x^*U ; in other words, it is identified with the section $x \rightarrow (x, d_x f)$ of the *cotangent bundle*

$$\pi^* : T^*(U) = U \times M(1, n) \rightarrow U .$$

Every such a section $\Omega(x) = (x, \omega(x))$ is called a *differential form* on U . For every form Ω and every vector field X on U ,

$$x \rightarrow \omega(x)(v(x))$$

defines a smooth function on U . If $\phi : U \rightarrow W$ is a diffeomorphism, Ω a differential form on U , then ϕ transports Ω to the form $\phi_*\Omega$ on W such that for every $y \in W$, every $w \in T_y W$, then

$$\phi_*\Omega(y) = (y, \omega(d_y \phi^{-1}(w))) .$$

Denote by ϵ^j , $j = 1, \dots, n$ the field constantly equal to the functional e^j such that

$$(e^i(e_j))_{i,j} = I_n \in M(n, \mathbb{R}) .$$

Then every $\Omega \in \Gamma(T^*(U))$ is a unique linear combination

$$\Omega = \sum_j a_j \epsilon^j$$

the a_j being smooth functions on U . Sometimes one writes ∂x_j instead of ϵ^j .

If g is a riemannian metric on U , then by setting for every $v, w \in T_x U$,

$$\psi_v(w) := g(x)(v, w) \in \mathbb{R}$$

one defines a smooth *field of linear isomorphisms* $\Psi_g := \{\Psi_{g,x} : T_x(U) \rightarrow T_x^*(U)\}_{x \in U}$. This transforms vector fields into differential forms. For every $f \in \mathcal{C}^\infty(U, \mathbb{R})$, let $\nabla_g f$ be the unique vector field on U such that $\Psi_g(\nabla_g f) = df$, so that for every $x \in U$, $v \in T_x(U)$, then

$$d_x f(v) = (\nabla_g(x), v)_{g(x)} .$$

The field $\nabla_g f$ is called the *gradient of f with respect to the metric g* . Clearly for every $x \in U$, $d_x f(\nabla_g(x)) = (\nabla_g(x), \nabla_g(x))_{g(x)} \geq 0$ and is strictly positive if and only if $d_x f \neq 0$.

Obviously every U admits riemannian metrics, for example any constant one $g_A(x) = A$ where A is a symmetric positive definite matrix. In particular $g_0 := g_{I_n}$ is called the *standard riemannian metric*. We have that for every smooth function f on U ,

$$\nabla_{g_0} f(x) = d_x f^t .$$

1.6. Inverse function theorem and applications

Let $L \in \mathcal{L}(\mathbb{R}^n, \mathbb{R}^m)$ be a linear map of *maximal rank r* . There are a few possibilities and by elementary linear algebra, for every case there is a *normal form* up to pre or post composition with linear isomorphisms.

- If $r = n = m$, then $L \in GL(n, \mathbb{R})$ is invertible and the normal form is I_n obtained as

$$I_n = L \circ L^{-1} = L^{-1} \circ L .$$

- If $n < m$, then the rank r is equal to n and L is *injective*. Let us fix a direct sum decomposition

$$\mathbb{R}^m = L(\mathbb{R}^n) \oplus V$$

and a basis $\mathcal{B} = \mathcal{B}' \oplus \mathcal{B}''$ of \mathbb{R}^m adapted to the decomposition. This determines a linear isomorphism $\phi_{\mathcal{B}} : \mathbb{R}^m \rightarrow \mathbb{R}^n \times \mathbb{R}^{m-n}$ such that for every $x = (x_1, \dots, x_n)^t \in \mathbb{R}^n$, we have

$$\phi_{\mathcal{B}} \circ L(x) = (x_1, \dots, x_n, 0, \dots, 0)^t$$

that is the standard inclusion $j = j_{n,m} : \mathbb{R}^n \rightarrow \mathbb{R}^m = \mathbb{R}^n \times \mathbb{R}^{m-n}$. This is the normal form in this case.

- If $n > m$, then the rank r is equal to m and L is *surjective*. Fix a direct sum decomposition

$$\mathbb{R}^n = V \oplus \ker(L)$$

and an adapted basis $\mathcal{B} = \mathcal{B}' \oplus \mathcal{B}''$ of \mathbb{R}^n . This determines a linear isomorphism (in fact the inverse of the above defined $\phi_{\mathcal{B}}$) $\psi_{\mathcal{B}} : \mathbb{R}^m \times \mathbb{R}^{n-m} \rightarrow \mathbb{R}^n$ such that for every $x = (x_1, \dots, x_n)^t \in \mathbb{R}^m \times \mathbb{R}^{n-m}$, we have

$$L \circ \psi_{\mathcal{B}}(x) = (x_1, \dots, x_m)$$

that is the natural projection $\pi_{n,m} : \mathbb{R}^m \times \mathbb{R}^{n-m} \rightarrow \mathbb{R}^m$. This is the normal form in this case.

Let us consider now a morphism $f \in \mathcal{C}^\infty(U, W)$ in our favourite category, $U \subset \mathbb{R}^n$, $W \subset \mathbb{R}^m$, $p \in U$. Assume that $d_p f$ has maximal rank r . The following fundamental theorems state that locally in a neighbourhood of p in U , the map f takes the same normal form of the linear map $d_p f$, up to pre or post composition with smooth diffeomorphisms. As a first step, let us remark that the *punctual* hypothesis has in fact a *local* valence. By a well known criterion $d_p f$ has maximal rank r if and only if there is a $r \times r$ submatrix $A(p)$ of $d_p f$ such that $\det A(p) \neq 0$. By taking the same submatrix $A(x)$ of $d_x f$ for every $x \in U$, we define the smooth function

$$\det A : U \rightarrow \mathbb{R}, \quad x \rightarrow \det A(x) .$$

Then by the “sign permanence”, there exists an open neighbourhood $U' \subset U$ of p in U , such that for every $x \in U'$, $d_x f$ has maximal rank r .

A map $f \in \mathcal{C}^\infty(U, W)$ such that for every $x \in U$, $d_x f$ is injective is called an *immersion*. If $d_x f$ is surjective for every $x \in U$, then f is called a *summersion*. If $n = m$ the two notions coincide. We can state now the theorem mentioned in the title.

THEOREM 1.2. (Inverse function theorem) *Let $f \in \mathcal{C}^\infty(U, W)$, $U, W \subset \mathbb{R}^n$, such that for every $p \in U$, the differential $d_p f$ is invertible. Then f is a local diffeomorphism, that is for every $p \in U$ there is a open neighbourhood U' of p in U such that $W' = f(U')$ is an open subset of W and the restriction $f|_{U'} \in \mathcal{C}^\infty(U', W')$ is a diffeomorphism.*

COROLLARY 1.3. ((Local immersion theorem) *Let $f \in \mathcal{C}^\infty(U, W)$, $U \subset \mathbb{R}^n$, $W \subset \mathbb{R}^m$, $n < m$, be an immersion. Then for every $p \in U$ there exist*

- *An open neighbourhood U' of p in \mathbb{R}^n ;*
- *an open neighbourhood W' of $q = f(p)$ in W ;*
- *an open neighbourhood W'' of 0 in \mathbb{R}^m and a diffeomorphism*

$$\phi : (W', q) \rightarrow (W'', 0)$$

such that for every $x \in U'$, $x + p \in U$, $f(x + p) \in W'$ and

$$\phi \circ f(x + p) = j_{n,m}(x) .$$

COROLLARY 1.4. (Local summersion theorem) *Let $f \in \mathcal{C}^\infty(U, W)$, $U \subset \mathbb{R}^n$, $W \subset \mathbb{R}^m$, $n > m$, be a summersion. Then for every $p \in U$ there exist*

- *An open neighbourhood U' of p in U ;*
- *an open neighbourhood U'' of 0 in \mathbb{R}^n and a diffeomorphism*

$$\psi : (U'', 0) \rightarrow (U', p)$$

such that $f(U') \subset W$ and

$$f \circ \psi(x) - f(p) = \pi_{n,m}(x) .$$

Proof of the Corollaries. In both cases it is not restrictive to assume that $p = 0$ and $f(0) = 0$. We will use the notations introduced at the beginning of the section, by replacing L with d_0f .

(*Immersion*s) Given a direct sum decomposition of $\mathbb{R}^m = d_0f(\mathbb{R}^n) \oplus V$, with adapted basis $\mathcal{B} = \mathcal{B}' \oplus \mathcal{B}''$ and associated linear isomorphism

$$\psi_{\mathcal{B}} : \mathbb{R}^n \times \mathbb{R}^{m-n} \rightarrow \mathbb{R}^m$$

consider the smooth map

$$g : U \times \mathbb{R}^{m-n} \rightarrow \mathbb{R}^m, \quad g(x, h) = f(x) + \psi_{\mathcal{B}}(0, h) .$$

It is easy to verify that $d_{(0,0)}g$ is invertible and we can apply the inverse function theorem to g on a neighbourhood $U' \times A$ of $(0, 0)$. By construction, for every $x \in U'$, $f(x) = g \circ j_{n,m}(x)$, so that $g^{-1} \circ f(x) = j_{n,m}(x)$.

(*Summersion*s) Given a direct sum decomposition $\mathbb{R}^n = V \oplus \ker(d_0f)$ with adapted basis $\mathcal{B} = \mathcal{B}' \oplus \mathcal{B}''$ and associated linear isomorphism

$$\phi_{\mathcal{B}} : \mathbb{R}^n \rightarrow \mathbb{R}^m \times \mathbb{R}^{n-m}$$

set $p : \mathbb{R}^m \times \mathbb{R}^{n-m} \rightarrow \mathbb{R}^{n-m}$ the natural projection. Define

$$g : U \rightarrow \mathbb{R}^m \times \mathbb{R}^{n-m}, \quad g(x) = (f(x), p(\phi_{\mathcal{B}}(x))) .$$

One verifies that d_0g is invertible, so we can apply the inverse function theorem to g on a neighbourhood U' of 0. By construction, for every $x \in U'$, $f(x) = \pi_{n,m} \circ g(x)$, and we conclude similarly to the case of immersions above. \square

Corollaries 1.3 and 1.4 are instances of the following general *constant rank theorem*. The proof, based again on the Inverse Function Theorem, is a simple variation and is left as an exercise.

THEOREM 1.5. (Constant rank theorem) *Let $f : U \rightarrow W$ be a smooth map, $U \subset \mathbb{R}^n$, $W \subset \mathbb{R}^m$ be open sets. Assume that $d_x f$ is of constant rank $k \leq \min\{n, m\}$. Then for every $p \in U$, $q = f(p)$ up to pre and post composition with local diffeomorphisms $\psi : U' \rightarrow U$, $\psi(0) = p$, $\phi : W' \rightarrow W$, $\phi(0) = q$ we have that*

$$\rho := \phi^{-1} \circ f \circ \psi : U' \rightarrow W', \quad \rho(u_1, \dots, u_n) = (u_1, \dots, u_k) .$$

\square

Strictly related to the local summersion theorem there is another corollary known as the *implicit function theorem*. A consequence of the proof of Corollary 1.4 is that there is a diffeomorphism $\rho : A \times B \rightarrow U'$, where $A \times B \subset \mathbb{R}^{n-m} \times \mathbb{R}^m$ is an open neighbourhood of $(x_0, y_0) = (0, 0)$ and U' is an open neighbourhood of 0 in $U \subset \mathbb{R}^n$, such that restriction of $g = f \circ \rho$ to $A \times B$ verifies:

- (1) $g(x_0, y_0) = 0$;
- (2) The restriction \tilde{g} of g to $\mathbb{R}^m = \{x_0\} \times \mathbb{R}^m$ has invertible differential $d_{y_0}\tilde{g}$ at y_0

We take such a situation as the hypotheses of the implicit function theorem.

COROLLARY 1.6. (Implicit function theorem) *Let $A \times B \subset \mathbb{R}^k \times \mathbb{R}^m$ be an open set. Let $g : A \times B \rightarrow \mathbb{R}^m$ be a smooth map and $(x_0, y_0) \in A \times B$ such that $g(x_0, y_0) = 0$. Let \tilde{g} be the restriction of g to $\mathbb{R}^m = \{x_0\} \times \mathbb{R}^m$. Assume that $d_{y_0}\tilde{g}$ is invertible. Then there exist an open neighbourhood $A' \times B'$ of (x_0, y_0) in $A \times B$, and a smooth maps $h : A' \rightarrow B'$ such that*

$$\text{Graph}(h) = f^{-1}(0) \cap A' \times B' .$$

It follows that $f(x, h(x)) = 0$ for every $x \in U'$ and h is said to be (locally) *implicitly defined by the equation* $f(x, y) = 0$.

Sketch of proof. We use similar arguments as in the proofs of the previous corollaries. Consider the smooth map

$$G : A \times B \rightarrow \mathbb{R}^k \times \mathbb{R}^m, \quad G(x, y) = (x, g(x, y)) .$$

It is immediate to check that $d_{(x_0, y_0)}G$ is invertible, so we can apply the inverse function theorem to G in a neighbourhood $A_1 \times B'$ of (x_0, y_0) , and the inverse map is necessarily of the form

$$G^{-1}(x, y) = (x, l(x, y))$$

for a suitable smooth map

$$l : G(A_1 \times B') \rightarrow B' .$$

Take

$$A' = \{x \in U; (x, 0) \in G(U_1 \times W')\}$$

and define $h(x) = l(x, 0)$. The reader can complete by exercise the verification that $A' \subset A_1$ and this eventually achieves the proof. \square

A proof of the inverse function theorem should be known to the reader. A current conceptual proof is based on *Banach's principle* for contractions on complete metric spaces. This is suited for generalizations to infinite dimensional Banach spaces. However we just sketch one in our finite dimensional situation, based on elementary properties of continuous functions on compact spaces.

Sketch of a proof of the inverse function theorem. We can assume for simplicity, and it is not restrictive, that $p = 0$ and $f(p) = 0$. Possibly by composing f with $(d_0f)^{-1}$ we can also assume that $d_0f = I_n$.

The proof is achieved by following the next sequence of claims.

Claim 1. There is a sufficiently small closed ball $\bar{B} = \bar{B}^n(0, \epsilon) \subset U$ such that

- (1) For every $x \in \bar{B}$, $d_x f$ is invertible;
- (2) For every $x \in \bar{B}$, $x \neq 0$, then $f(x) \neq 0$;
- (3) For every $x, z \in \bar{B}$, $2\|f(x) - f(z)\| \geq \|x - z\|$.

Assuming these facts, by the continuity of the function and the compactness of $\partial\bar{B}$, there is $\delta > 0$ such that for every $x \in \partial\bar{B}$, $\|f(x)\| \geq \delta$. Consider the open ball $B' = B^n(0, \delta/2)$.

Claim 2. Set $A = B \cap f^{-1}(B')$. Then the restriction $\phi : A \rightarrow B'$ of f to the open set A is bijective.

Claim 3. ϕ is a homeomorphism.

Claim 4. ϕ is a diffeomorphism

Proof of Claim 1. The first point is evident. Assuming that the second point fails, there would be a sequence x_n in U , converging to 0, such that $f(x_n) = 0$ for every n . Hence $\|\frac{f(x_n) - x_n}{x_n}\| = 1$ against the fact that $d_0f = I_n$. As for the third point, consider the function $g(x) = f(x) - x$, so that

$$\|x - z\| - \|f(x) - f(z)\| \leq \|g(x) - g(z)\| .$$

As

$$\frac{\partial g_i}{\partial x_j}(x) = \frac{\partial f_i}{\partial x_j}(x) - \frac{\partial f_i}{\partial x_j}(0)$$

we can take ϵ in order to make $|\frac{\partial g_i}{\partial x_j}(x)| < \frac{1}{2n^2}$ uniformly on \bar{B} . Then the conclusive inequality

$$\|g(x) - g(z)\| \leq \frac{1}{2}\|x - z\|$$

is obtained by applying several times the Main Value Theorem for functions of one variable,

Proof of Claim 2. It is enough to prove that for every $y \in B'$ there is a unique $x \in U$ such that $f(x) = y$. The smooth function $h(x) = \|y - f(x)\|^2$ has a minimum point p on the compact set \bar{B} and by construction p belongs necessarily to the open ball B . A simple computation then shows that $d_p f(y - f(p)) = 0$, hence $y - f(p) = 0$ because $d_p f$ is invertible. As for the uniqueness, this follows by the inequality $\|p_1 - p_2\| \leq 2\|f(p_1) - f(p_2)\|$, so that $p_1 = p_2$ if $f(p_1) = f(p_2) = y$.

Proof of Claim 3. The same inequality implies that $\|\phi^{-1}(y_1) - \phi^{-1}(y_2)\| \leq 2\|y_1 - y_2\|$ and the continuity of ϕ^{-1} follows.

Proof of Claim 4. As we know, it is enough to show that ϕ^{-1} is differentiable. In fact by using directly the definition of the differential one can prove that $d_y \phi^{-1} = (d_x \phi)^{-1}$, where $y = \phi(x)$. The details are left to the reader. \square

1.7. Topologies on spaces of smooth maps

Let $U \subset \mathbb{R}^n$, $W \subset \mathbb{R}^m$ be open sets. For every $k \geq 0$ we define a topology δ_k on $\mathcal{C}^k(U, W)$; we will denote by $\mathcal{E}^k(U, W)$ the set $\mathcal{C}^\infty(U, W) \subset \mathcal{C}^k(U, W)$ endowed with the subspace topology. We determine δ_k by giving for every $f = (f_1, \dots, f_m) \in \mathcal{C}^k(U, W)$ a basis of open neighbourhoods $\mathcal{U}_k(f, K, \epsilon)$ where the varying arguments are a compact subset $K \subset U$ and a real $\epsilon > 0$. Then, by definition, $g \in \mathcal{C}^k(U, W)$ belongs to $\mathcal{U}_k(f, K, \epsilon)$ if and only if

- (1) For every $x \in K$, $\|g(x) - f(x)\| < \epsilon$;
- (2) For every multi-index J such that $|J| = r \leq k$, for every $i = 1, \dots, m$, for every $x \in K$, we have

$$\left\| \frac{\partial^J (g_i - f_i)}{\partial x_1^{j_1} \dots \partial x_n^{j_n}}(x) \right\| < \epsilon.$$

We omit the proof that this actually defines bases of neighbourhoods of some topologies.

We denote by $\mathcal{E}(U, W)$ the set $\mathcal{C}^\infty(U, W)$ endowed with the *union topology* $\delta = \cup_k \delta_k$.

All these are called *weak topologies*. This understands the existence of other *strong* topologies, say σ_k , on the same sets. By considering for example $\mathcal{E}(\mathbb{R}^n, \mathbb{R})$, we can control the difference of two functions, up to an arbitrarily prescribed order on an arbitrarily given compact set K , but we have not any control “at infinity”. The strong topologies σ_k , which contain δ_k being *heavily finer*, allow instead such a control at infinity. On another hand, the weak topologies δ_k have nice properties, for example one can prove that they are metrizable, hence every f has a countable basis of open neighbourhoods. On the contrary this is not the case for the strong topologies; for example if a sequence $g_n \rightarrow f$ in $\mathcal{C}^k(\mathbb{R}^n, \mathbb{R})$ with the strong topology, then there exists a compact set K in \mathbb{R}^n such that g_n definitely equal f on the complement of K . However, *we do not define the strong topologies*. To our aims, the control at compact sets will suffice.

Let us recall also (a particular case of) the classical *Stone-Weierstrass theorem* (see [Stone]).

THEOREM 1.7. *For every $f \in \mathcal{C}^k(U, \mathbb{R}^m)$, for every $k \geq 0$, for every neighbourhood $\mathcal{U} = \mathcal{U}_k(f, K, \epsilon)$, there exists a polynomial map $p : \mathbb{R}^n \rightarrow \mathbb{R}^m$ such that the restriction of p to U belongs to \mathcal{U} . In other words, the polynomial maps are dense in $\mathcal{C}^k(U, \mathbb{R}^m)$ for every $k \geq 0$ and in $\mathcal{E}(U, W)$.*

1.8. Stability of summersions and immersions at a compact set

Let $f \in \mathcal{C}^k(U, W)$ be as above, $k \geq 1$, $K \subset U$ a compact set. We say that f is a *summersion* (resp. an *immersion*) at K if for every $x \in K$, $d_x f$ is surjective (resp. injective). This is equivalent to the fact that there exists an open neighbourhood $K \subset U' \subset U$ such that the restriction of f to U' is a summersion (immersion). Here is the stability results.

PROPOSITION 1.8. *If f is either (1) a summersion, (2) an immersion or (3) an injective immersion at K , then there is a neighbourhood $\mathcal{U} = \mathcal{U}_1(f, K, \epsilon)$ such that every $g \in \mathcal{U}$ shares the same properties of f respectively.*

Proof : If $n \geq m$ (resp. $n < m$), then every $m \times n$ matrix A has $\binom{n}{m}$ $m \times m$ (resp. $\binom{m}{n}$) submatrices say A_j ; in any case define

$$\delta(A) = \sum_j (\det A_j)^2 .$$

In both cases (1) and (2) the hypothesis is equivalent to $d(x) := \delta(d_x f) > 0$ for every $x \in K$. As d is continuous and K is compact, then

$$\sup_{x \in K} \{d(x)\} = \max_{x \in K} \{d(x)\} = d_0 > 0 .$$

Then it is clear that if g is close enough to f at K in $\mathcal{C}^1(U, W)$, then $\delta(d_x g) > 0$ for every $x \in K$. As for (3), assume that the thesis fails. Then there would exist a sequence $g_n \in \mathcal{C}^1(U, W)$, sequences of points x_n, y_n in the compact set K such that:

- (1) Every g_n is an immersion at K (by (2));
- (2) $g_n \rightarrow f$ and $dg_n \rightarrow df$ uniformly on K ;
- (3) $x_n \rightarrow x, y_n \rightarrow y$ in $K, x_n \neq y_n$ and $g_n(x_n) = g_n(y_n)$ for every n .
- (4) $v_n := \frac{x_n - y_n}{\|x_n - y_n\|} \rightarrow v \in S^{n-1}$ (by the compactness of the unitary sphere S^{n-1}).

Then: $g_n(x_n) \rightarrow f(x), g_n(y_n) \rightarrow f(y)$, hence $x = y$ because f is injective. Hence

$$\|g_n(x_n) - g_n(y_n) - d_{y_n} g_n(x_n - y_n)\| / \|x_n - y_n\| \rightarrow 0$$

uniformly, so that

$$\|d_{y_n} g_n(v_n)\| \rightarrow \|d_x f(v)\| = 0 .$$

This is absurd because $d_x f$ is injective. □

1.9. An elementary division theorem

By definition a *convex* subset C of \mathbb{R}^n has the property that for every $x_0, x_1 \in C$, the (parametrized) segment $\gamma : [0, 1] \rightarrow \mathbb{R}^n, \gamma(t) = (1-t)x_0 + tx_1$ is entirely contained in C . We have

THEOREM 1.9. (Elementary division theorem) *Let $f = (f_1, \dots, f_m) \in \mathcal{C}^\infty(U, \mathbb{R}^m)$ where $U \subset \mathbb{R}^n$ is a convex open subset. Assume that $0 \in U$ and $f(0) = 0$. Then there are smooth maps $g_j = (g_{j1}, \dots, g_{jm}) : U \rightarrow \mathbb{R}^m, j = 1, \dots, n$, such that for every $x \in U, f(x) = \sum_j x_j g_j(x)$, and (necessarily) $g_{ji}(0) = \frac{\partial f_i}{\partial x_j}(0)$.*

Proof : It is a basic property of elementary integration that for every smooth function $h : U \rightarrow \mathbb{R}$, the function $\tilde{h} : U \rightarrow \mathbb{R}$ defined by $\tilde{h}(x) = \int_0^1 h(tx)dt$ is smooth. By the fundamental theorem of elementary integration for continuous functions, we have that

$$f(x) = \int_0^1 \frac{df(tx)}{dt} dt = \left(\int_0^1 \frac{df_1(tx)}{dt} dt, \dots, \int_0^1 \frac{df_m(tx)}{dt} dt \right) .$$

By the chain rule, for every $i = 1, \dots, m$,

$$\int_0^1 \frac{df_i(tx)}{dt} dt = \int_0^1 \left(\sum_j x_j \frac{\partial f_i}{\partial x_j}(tx) \right) dt = \sum_j x_j \int_0^1 \frac{\partial f_i}{\partial x_j}(tx) dt .$$

We achieve the proof by setting

$$g_{ji}(x) := \int_0^1 \frac{\partial f_i}{\partial x_j}(tx) dt$$

□

REMARKS 1.10. (1) The same arguments in the above proof work as well by assuming only that U is *starred* with center at 0.

(2) In the setting of the division theorem, if $n = m = 1$, we have that $f(x) = xg(x)$, that is the coordinate function x divides f . Assume now $m = 1$, f is defined on an open set of the form $U = A \times (-1, 1) \subset \mathbb{R}^{n-1} \times \mathbb{R}$ and that $\{f = 0\} = U \cap \{x_n = 0\}$. Then by applying fibre by fibre the same construction of the above proof, we get that $f(x) = x_n g(x)$. Moreover, if f is a summersion, then $g(x)$ is nowhere vanishing.

We will see several applications of the division theorem.

1.10. A differential interpretation of the tangent spaces: derivations

Above we have introduced the tangent spaces $T_x U$, mainly by considering U as an open set of the *affine* space \mathbb{R}^n . Here we give a genuine differential interpretation, compatible with the already defined tangent functor.

Let $p \in U$. Consider the set of smooth functions $f : U' \rightarrow \mathbb{R}$ defined on some open neighbourhood U' of p in U . On this set put the equivalence relation such that $(U_1, f_1) \sim (U_2, f_2)$ if and only if there is (U_3, f_3) such that $U_3 \subset U_1 \cap U_2$ and for every $y \in U_3$ $f_3(y) = f_1(y) = f_2(y)$. Denote by \mathcal{E}_p the quotient set. Note that U is immaterial for this purely local definition, as we would get the same \mathcal{E}_p by taking for instance the whole of \mathbb{R}^n instead of U . Similarly also $T_p = T_p U$ essentially does not depend on the choice of the open set containing p . Denote by $[f] = [f]_p$ an equivalence class. The usual sum and product defined on every $\mathcal{C}^\infty(U', \mathbb{R})$ induce well defined sum and product on \mathcal{E}_p which make it a *commutative ring* as well a real *vector space* with compatible operations. The translation $x \rightarrow x - p$ determines a canonical isomorphism between \mathcal{E}_p and \mathcal{E}_0 , then the considerations we are going to do for \mathcal{E}_0 can be straightforwardly transported to \mathcal{E}_p by this translation. Let $v = (v_1, \dots, v_n)^t \in T_0 \sim \mathbb{R}^n$. By means of the usual *derivative at 0 in the direction* v , we define the function

$$\delta_v : \mathcal{E}_0 \rightarrow \mathbb{R}, \quad \delta_v([f]) = \sum_j \frac{\partial f}{\partial x_j}(0) v_j .$$

One verifies easily that δ_v is well defined (it does not depend on the choice of the representative f), is \mathbb{R} -linear, and moreover verifies the *Leibniz identity*:

$$\delta_v([f][g]) = f(0)\delta_v([g]) + g(0)\delta_v([f]) .$$

Let us call a *derivation on \mathcal{E}_0* any map $\delta : \mathcal{E}_0 \rightarrow \mathbb{R}$ that verifies the same properties. Set $\text{Der}(\mathcal{E}_0)$ the set of these derivation. It has a natural structure of real vector space, so that the map

$$L : T_0 \rightarrow \text{Der}(\mathcal{E}_0), \quad L(v) = \delta_v$$

is \mathbb{R} -linear. Let us prove that L is a *linear isomorphism*. For every derivation δ we will find a unique $v \in T_0$ such that $\delta = \delta_v$. It follows immediately from the derivation properties that for every constant germ $[f]$ (i.e. with a constant representative), $\delta([f]) = 0$. For every $[f]$ we can take a representative f defined on a small open ball $B^n(0, \epsilon)$ (which is convex). By the division theorem, for every x in such a ball,

$$f(x) - f(0) = \sum_j g_j(x)x_j$$

for some smooth functions g_j . Then, by using again the derivation properties, we have

$$\delta([f]) = \sum_j \frac{\partial f}{\partial x_j}(0)\delta([x_j])$$

hence we conclude by taking $v = (\delta([x_1]), \dots, \delta([x_n]))$. □

The above discussion can be *globalized* by replacing T_p with the set $\Gamma(T(U))$ of (tangent) vector fields on U , and \mathcal{E}_p with the commutative ring $\mathcal{C}^\infty(U, \mathbb{R})$ with the induced compatible structure of \mathbb{R} -vector space. $\Gamma(T(U))$ is also in a natural way a vector space and this extends to a natural structure of $\mathcal{C}^\infty(U, \mathbb{R})$ -*module*. For every vector field $X \in \Gamma(T(U))$, define

$$\delta_X : \mathcal{C}^\infty(U, \mathbb{R}) \rightarrow \mathcal{C}^\infty(U, \mathbb{R}), \quad \delta_X(f)(x) = \delta_{X(x)}([f]_x) .$$

It is \mathbb{R} -linear and verifies the Leibniz rule

$$\delta_X(fg) = f\delta_X(g) + \delta_X(f)g$$

hence, by definition, it is a *derivation* on $\mathcal{C}^\infty(U, \mathbb{R})$. Finally the map

$$L : \Gamma(T(U)) \rightarrow \text{Der}(\mathcal{C}^\infty(U, \mathbb{R})), \quad L(X) = \delta_X$$

establishes an isomorphism of \mathcal{C}^∞ -modules.

Note that if $\delta, \delta' \in \text{Der}(\mathcal{E}_0)$ (resp. $\in \text{Der}(\mathcal{C}^\infty(U, \mathbb{R}))$) then $\delta\delta'$ is not in general a derivation, while $\delta\delta' - \delta'\delta$ is a derivation. In particular for every couple $X, Y \in \Gamma(T(U))$ there is a unique vector fields $[X, Y]$ such that

$$L([X, Y]) = L(X)L(Y) - L(Y)L(X) .$$

1.11. Morse lemma

Let $f \in \mathcal{C}^\infty(U, \mathbb{R})$, U open set of \mathbb{R}^n . A point $p \in U$ is *regular* for f if $d_p f \neq 0$ (that is f is a summersion near p); otherwise we say that p is *critical* (or also *singular*). We are interested to the local behaviour of f at p (actually to the germ $[f]_p$). Up to pre or post composition with a translation we can normalize the situation so that $p = 0$ and $f(0) = 0$. Moreover we can assume that $U = B^n(0, \epsilon_0)$ for some $\epsilon_0 > 0$ and, case by case, we can restrict f to any $U_\epsilon = B^n(0, \epsilon)$, $0 < \epsilon \leq \epsilon_0$. For every ϵ , the commutative ring $\mathcal{C}^\infty(U_\epsilon, \mathbb{R})$ has a canonical ideal

$$\mathfrak{m}_\epsilon = \{g \in \mathcal{C}^\infty(U_\epsilon, \mathbb{R}); g(0) = 0\}$$

so that we are assuming that $f \in \mathfrak{m}_\epsilon$. It is an immediate corollary of the division theorem that \mathfrak{m}_ϵ is generated by the coordinate functions x_j , $j = 1, \dots, n$; that is every $g \in \mathfrak{m}_\epsilon$ is a $\mathcal{C}^\infty(U_\epsilon, \mathbb{R})$ -linear combination of the coordinate functions. Hence we have that for $x \in U$,

$$f(x) = \sum_j g_j(x)x_j, \quad d_0 f = (g_1(0), \dots, g_n(0)) .$$

If 0 is a regular point for f , the particular case of theorem 1.4 can be rephrased by saying that, up to pre composition with a local diffeomorphism, f locally coincides with d_0f that is its first Taylor polynomial $T_1(f)(0)$.

If 0 is critical, then all the smooth functions g_j vanish at 0, and we can apply again to each of them the division theorem and eventually we get that on U

$$f(x) = \sum_{|J|=2} g_J(x)x^J, \quad x^J := x_1^{j_1} \dots x_n^{j_n}$$

that is it has the form of a homogeneous polynomial of degree 2 whose coefficients are smooth functions. Moreover

$$T_2(f)(0) = \sum_{|J|=2} g_J(0)x_1^{j_1} \dots x_n^{j_n}.$$

In fact we can express $T_2(f)(0)$ in the form

$$T_2(f)(0) = \frac{1}{2}x^t H_0(f)x := Q_0(f)(x)$$

where $H_0(f)$ is the *symmetric* (by Schwartz Lemma) *Hessian matrix* of f at 0

$$H_0(f) = \left(\frac{\partial^2 f}{\partial x_i \partial x_j}(0) \right)_{i,j=1,\dots,n}$$

while $Q_0(f)$ is the associated *quadratic form*. We can organize the above functions $g_{i,j}$ to rewrite f on U as

$$f(x) = x^t G(x)x$$

where

$$G : U \rightarrow M(n, \mathbb{R})$$

is a smooth map such that $G(x) = G(x)^t$ is symmetric for every $x \in U$, and $G(0) = T_2(f)(0)$.

We say that the critical point $x = 0$ is *non degenerate* if

$$\det H_0(f) \neq 0.$$

We have the following characterization of non degenerate critical points. For every U_ϵ , denote by $J(f, \epsilon)$ the *Jacobian ideal* of $\mathcal{C}^\infty(U_\epsilon, \mathbb{R})$ generated by the partial derivative functions $\frac{\partial f}{\partial x_j}$, that is the ideal of the $\mathcal{C}^\infty(U_\epsilon, \mathbb{R})$ -linear combinations $\sum_j h_j \frac{\partial f}{\partial x_j}$, $h_j \in \mathcal{C}^\infty(U_\epsilon, \mathbb{R})$. If 0 is a critical point, then $J(f, \epsilon) \subset \mathfrak{m}_\epsilon$. Then we have

LEMMA 1.11. *0 is a non degenerate critical point of $f \in \mathcal{C}^\infty(U, \mathbb{R})$, $f(0) = 0$, if and only if there exists $0 < \epsilon \leq \epsilon_0$ such that $J(f, \epsilon) = \mathfrak{m}_\epsilon$.*

Proof : It is enough to prove the inclusion “ \supseteq ”, then it is enough to show that the generating coordinate functions x_j belong to $J(f, \epsilon)$ for some ϵ . As 0 is non degenerate, the smooth map

$$x \rightarrow \left(\frac{\partial f}{\partial x_1}(x), \dots, \frac{\partial f}{\partial x_n}(x) \right)$$

has invertible differential at 0, then we can apply the inverse map theorem locally on a neighbourhood U_ϵ of 0, so that there are smooth functions F_j such that for every $j = 1, \dots, n$, $F_j(0) = 0$ and

$$x_j = F_j \left(\frac{\partial f}{\partial x_1}, \dots, \frac{\partial f}{\partial x_n} \right).$$

Again by the division theorem we finally get

$$x_j = \sum_i G_{j,i}(x) \frac{\partial f}{\partial x_i}(x)$$

and the Lemma is proved.

□

Assume that 0 is a non degenerate critical point for f . We are going to prove that up to pre composition with local diffeomorphisms at 0, f locally coincides with $T_2(f)(0)$. More precisely, the Hessian matrix $H_0(f)$ has a certain *index of negativity* $0 \leq \lambda \leq n$ (i.e. the maximal dimension of the linear subspaces of \mathbb{R}^n on which the restriction of the quadratic form $Q_0(f)$ is negative). By definition λ is the *index of the non degenerate critical point* 0. This notion is stable under local diffeomorphism.

LEMMA 1.12. *If 0 is a non degenerate critical point of index λ of $f \in \mathcal{C}^\infty(U_\epsilon, \mathbb{R})$, $f(0) = 0$, and $\phi : W \rightarrow U_\epsilon$ is a diffeomorphism, $\psi(0) = 0$, then 0 is a non degenerate critical point of $f' := f \circ \phi$ of index λ .*

Proof : By direct computation, using the chain rule and the fact that $d_0 f = 0$, we have

$$H_0(f') = d_0 \phi^t H_0(f) d_0 \phi$$

hence the symmetric matrices $H_0(f')$ and $H_0(f)$ are congruent so they are both non singular and have the same signature.

□

Let 0 be a non degenerate critical point of f of index λ . Up to composition with a linear isomorphism $x = Pu$, we have that

$$Q_0(f)(Pu) = -\left(\sum_{j=1}^{\lambda} u_j^2\right) + \left(\sum_{j=\lambda+1}^n u_j^2\right) = u^t I_{n,\lambda} u$$

where $I_{n,\lambda}$ is the suitable diagonal matrix with ± 1 entries. Finally we can state

THEOREM 1.13. (Morse Lemma) *Let 0 be a non degenerate critical point of index $0 \leq \lambda \leq n$ of $f \in \mathcal{C}^\infty(U, \mathbb{R})$, $f(0) = 0$. Then there is a local diffeomorphism $x = \phi(u)$, $0 = \phi(0)$, such that $\psi := \phi^{-1}$ is defined on some U_ϵ and*

$$f(\phi(u)) = u^t I_{n,\lambda} u .$$

Proof : It is not restrictive to assume that

$$H_0(f) = I_{n,\lambda} .$$

Let us take as above on U an expression

$$f(x) = x^t G(x) x .$$

If $\epsilon > 0$ is small enough, we have that on U_ϵ every symmetric matrix $G(x)$ has negativity index λ , and by applying to the canonical basis of \mathbb{R}^n the usual algorithm producing a normalized orthogonal basis with respect to the scalar product $(*, *)_{G(x)}$, we eventually get a smooth map

$$P : U_\epsilon \rightarrow \text{GL}(n, \mathbb{R})$$

such that:

- (1) $P(0) = I_n$;
- (2) For every $x \in U_\epsilon$, the linear isomorphism $x = P(x)u$ is such that

$$P(x)^t G(x) P(x) = I_{n,\lambda} .$$

Then consider the smooth map

$$\psi : U_\epsilon \rightarrow \mathbb{R}^n, \quad \psi(x) = P(x)^{-1} x$$

one verifies that ψ has invertible differential at 0, so by the inverse map theorem, possibly by shrinking ϵ , $u = \psi(x)$ is a diffeomorphism onto its open image and finally

$$f(x) = x^t G(x) x = u^t I_{n,\lambda} u$$

as desired. □

Let us state, without proof, an interesting generalization of Morse's Lemma. With the usual notation, for every $k \geq 1$, define \mathfrak{m}_ϵ^k as the ideal of $\mathcal{C}^\infty(U_\epsilon, \mathbb{R})$ generated by the monomials $x^J = x_1^{j_1} \dots x_n^{j_n}$, J be an arbitrary multi-index with $|J| = k$. Clearly $\mathfrak{m}_\epsilon = \mathfrak{m}_\epsilon^1 \subset \mathfrak{m}_\epsilon^2 \subset \dots$. We have

PROPOSITION 1.14. *Let $f \in \mathcal{C}^\infty(U, \mathbb{R})$, $f(0) = 0$, be such that 0 is a critical point, and there is $k \geq 1$ such that $\mathfrak{m}_\epsilon^k \subset J(f, \epsilon)$. Then up to pre composition with a local diffeomorphism at 0, f locally coincides with the Taylor polynomial $T_k(f)(0)$.*

1.12. Bump functions and partitions of unity

Consider the function $\alpha : \mathbb{R} \rightarrow \mathbb{R}$ defined by $\alpha(x) = 0$ if $x \leq 0$, $\alpha(x) = e^{-\frac{1}{x}}$ if $x > 0$. One verifies that α is smooth and that for every $k \geq 1$, $\frac{d^k \alpha}{dx^k}(0) = 0$. Then we say that α is *flat* at 0, although α is not locally constant at 0. This phenomenon is an important feature of the “flexibility” of smooth functions that makes them suited for topological applications. On the contrary, for example, analytic functions are much more rigid: an analytic function on \mathbb{R} which is flat at some points is constant.

Let us fix two real numbers $0 < a < b$. Define $\beta = \beta_{a,b} : \mathbb{R} \rightarrow \mathbb{R}$,

$$\beta(x) = \alpha(x-a)\alpha(b-x).$$

Hence β is smooth, $\beta(x) = 0$ on $\{x \leq a\} \cup \{x \geq b\}$, is strictly positive on $\{a < x < b\}$ with a unique maximum; β is flat at a and b .

Define $\gamma = \gamma_{a,b} : \mathbb{R} \rightarrow \mathbb{R}$ by

$$\gamma(x) = \frac{\int_{|x|}^b \beta(t) dt}{\int_a^b \beta(t) dt}.$$

Then γ is smooth, $\gamma(x) = 1$ if $|x| \leq a$, $\gamma(x) = 0$ if $|x| \geq b$, $0 \leq \gamma(x) \leq 1$ and is monotone on each connected interval of $\{a < |x| < b\}$; γ is flat at $\pm a$ and $\pm b$. For every $n \geq 1$ we can define $\gamma_n : \mathbb{R}^n \rightarrow \mathbb{R}$, $\gamma_n = \gamma_{n,a,b}(x) = \gamma_{a,b}(|x|)$, however we will omit the index n whenever the dimension is clear by the context. Such a function $\gamma_{a,b} : \mathbb{R}^n \rightarrow \mathbb{R}$ is called a *bump function* on \mathbb{R}^n with center 0 and rays a, b . If $\tau_p(x) = x - p$, then

$$\gamma_{p,a,b} = \gamma_{a,b} \circ \tau_p$$

is a bump function with center p ; when the center is clear from the context we will omit also to indicate it.

Recall that the *support* of a function is the closure of the set where it is not zero. Hence $\overline{B}^n(p, b)$ is the support of $\gamma_{p,a,b}$.

We introduce also bump functions “at infinity” as follows. Let $\mathbb{R}^n \subset \mathbb{R}^{n+1}$ as the hyperplane with equation $x_{n+1} = 0$. Denote by $\pi^+ : S^n \setminus \{e_{n+1}\} \rightarrow \mathbb{R}^n$ ($e_{n+1} = (0, \dots, 0, 1)$) the *stereographic projection* defined geometrically by

$$\pi^+(x) = r(x, e_{n+1}) \cap \mathbb{R}^n$$

where $r(x, e_{n+1})$ is the straight line passing through the two points. Similarly define the projection $\pi^- : S^n \setminus \{-e_{n+1}\} \rightarrow \mathbb{R}^n$. One easily verifies by direct computation that

$$\rho := \pi^- \circ (\pi^+)^{-1} : \mathbb{R}^n \setminus \{0\} \rightarrow \mathbb{R}^n \setminus \{0\}$$

is a diffeomorphism. Then a *bump function at infinity* is by definition of the form $\gamma_\infty(x) = \gamma \circ \rho(x)$ if $x \in \mathbb{R}^n \setminus \{0\}$, $\gamma_\infty(0) = 0$ which clearly is smooth.

We extend now the definition to bump functions at an arbitrary compact subset of $K \subset \mathbb{R}^n$, as follows. Let $K \subset \mathbb{R}^n$ be a compact set, U an open neighbourhood of K . Then we can find $W_0 := U_{\infty, a_\infty} := \mathbb{R}^n \setminus \overline{B}^n(0, a_\infty)$, some $W_j := B^n(p_j, b_j)$, $j = 1, \dots, k$, and some $0 < a_j < b_j$, $a_\infty < b_\infty$ such that:

- (1) $\overline{W}_0 \cap K = \emptyset$;
- (2) The open balls $U_j := B^n(p_j, a_j)$ together with $U_0 := U_{\infty, b_\infty}$ make a finite open covering \mathcal{U} of \mathbb{R}^n ;
- (3) The union of the above open balls that intersect K is an open neighbourhood $U' \subset U$ of K .

Denote by γ_0 the bump function at infinity with support equal to \overline{W}_0 and constantly equal to 1 on U_0 ; by γ_j the bump function at p_j with rays a_j, b_j . For every $j = 0, \dots, k$, define the smooth function

$$\lambda_j := \frac{\gamma_j}{\sum_j \gamma_j} .$$

By the properties of the covering \mathcal{U} and of the bump functions, the denominator is strictly positive everywhere. Clearly, for every $x \in \mathbb{R}^n$,

$$\sum_j \lambda_j(x) = 1 .$$

Such a family of function $\{\lambda_j\}$ is called a *partition of unity subordinate to the (finite) covering* \mathcal{U} . Now we define “local” constant functions $c_j : W_j \rightarrow \mathbb{R}$, such that $c_j = 1$ if $U_j \cap K$ is non empty, $c_j = 0$ otherwise. Finally set

$$\gamma_K = \sum_j \lambda_j c_j .$$

By construction it is smooth, it is constantly equal to 1 on U' and has compact support contained in U . Any γ_K constructed in this way is called a *bump function at K*.

Bump functions are an important device. A basic use is the following: let U be an open neighbourhood of a compact set K as above, $f : U \rightarrow \mathbb{R}$ be a smooth function *locally* defined at K . In certain cases it is useful to find a *globally* defined smooth function $\hat{f} : \mathbb{R}^n \rightarrow \mathbb{R}$ with compact support and which locally agrees with f at K , that is there is an open neighbourhood $K \subset U' \subset U$ such that $f(x) = \hat{f}(x)$ for $x \in U'$. Take any bump function $\gamma = \gamma_K$ at K constructed as above; then \hat{f} defined by $\hat{f}(x) = \gamma(x)f(x)$ if $x \in U$, $\hat{f}(x) = 0$ if $x \in \mathbb{R}^n \setminus U$, does the job.

These partitions of unity provide also a very flexible way to construct riemannian metrics on \mathbb{R}^n . Let $\{\lambda_j\}$ be as above. Fix on every U_j an arbitrary riemannian metric g_j (for instance a constant one varying with j). Then

$$g = \sum_j \lambda_j g_j$$

is a well defined riemannian metric on the whole of \mathbb{R}^n .

In the next sections we will see a few other concrete applications.

REMARK 1.15. As \mathbb{R}^n is metrizable, locally compact and with a countable basis of open sets, one can prove that for every open set $U \subset \mathbb{R}^n$, for every open covering \mathcal{A} of U there exist a countable family of open balls $\mathcal{B} = \{B_j = B^n(p_j, b_j)\}_{j \in \mathbb{N}}$, and for every $j \in \mathbb{N}$, $0 < a_j < b_j$ such that

- (1) \mathcal{B} is a *refinement* of \mathcal{A} , that is it is an open covering of U and every B_j is contained in some $A \in \mathcal{A}$;
- (2) \mathcal{B} is *locally finite*, that is for every $p \in U$, there is a ball $B = B^n(p, r)$ which intersects only finitely many B_j 's;
- (3) Also $\mathcal{U} = \{B^n(p_j, a_j)\}_{j \in \mathbb{N}}$ is an open covering of U .

Take the corresponding family of bump functions $\{\gamma_j = \gamma_{p_j, a_j, b_j}\}$. Set, for every $j \in \mathbb{N}$

$$\lambda_j = \frac{\gamma_j}{\sum_{j=1}^{\infty} \gamma_j} .$$

This is well defined and smooth because, by the local finiteness, the denominator reduces at every point p to a strictly positive sum of a finite number of terms. Clearly for every p ,

$$\sum_j \lambda_j(p) = 1 .$$

The family $\{\lambda_j\}$ is called a partition of unity subordinate to the covering \mathcal{B} (which refines the given \mathcal{A}). For example, if $K \subset U$ is a compact set as above we could apply the construction to the open covering of \mathbb{R}^n , $\mathcal{A} = \{U, \mathbb{R}^n \setminus K\}$, and use the resulting partition function over \mathcal{B} to construct as well a bump function γ_K at K . These more general partitions of unity rely on a topological property called *paracompactness*; however, *we will not really need them*.

1.13. Homotopy, isotopy, diffeotopy

Here we fix a few notions and terminology that shall be widely employed and developed. U and V are open sets in Euclidean spaces. A map

$$F : U \times [0, 1] \rightarrow V$$

is *smooth* if it is the restriction of a smooth map defined on the open set $U \times J$, J being an open interval and $[0, 1] \subset J$. For every $t \in [0, 1]$, set f_t the restriction of F to $U \times \{t\}$. Then F is called a (smooth) homotopy between f_0 and f_1 . It can be considered as a continuous path in $\mathcal{E}(U, V)$ joining f_0 and f_1 .

We say that $f : U \rightarrow V$ is an *embedding* if f is an injective immersion and is a homeomorphism onto its image. If f_t is an embedding for every $t \in [0, 1]$, then F is called an *isotopy* between f_0 and f_1 .

If $U = V$ and f_t is a diffeomorphism for every $t \in [0, 1]$, then F is called a *diffeotopy*. In this case F can be reconsidered as follows: consider the map

$$H : U \times [0, 1] \rightarrow U \times [0, 1], \quad H(p, t) = (f_0(p), t) .$$

Then $G := F \circ H^{-1}$ is a diffeotopy between id_U and $f_1 \circ f_0^{-1}$, and $F = G \circ H$. This formal manipulation suggests nevertheless the following specialization of homotopy. If $G : V \times [0, 1] \rightarrow V$ is a diffeotopy between $g_0 = \text{id}_V$ and g_1 , and $\phi : U \times [0, 1] \rightarrow V \times [0, 1]$ is of the form $\phi(p, t) = (f(p), t)$ for some $f : U \rightarrow V$, then $G \circ F$ is called a *diffeotopy* between $f_0 := f$ and $f_1 := g_1 \circ f$; sometimes one also says that f_0 and f_1 are homotopic through an *ambient isotopy*.

Let $f : U \rightarrow U$ be a diffeomorphism. The *support* of f is the closure of the subset of U on which $f(x) \neq x$. If F is a diffeotopy between f and id_U the support of F is the closure of the union of the supports of the f_t 's.

Homotopy and its relatives define equivalence relations on the pertinent space of maps. Clearly $F(p, t) = (f(p), t)$ is a homotopy between f and itself. If F is a homotopy between f_0 and f_1 , then $\hat{F}(p, t) := F(p, 1 - t)$ is a homotopy between f_1 and f_0 . As for the transitivity: by using the 1-dimensional bump functions, we see that there exist a smooth function $s : [0, 1] \rightarrow [0, 1]$ and $1/3 > \epsilon > 0$ such that $s(t) = 0$ on $[0, \epsilon]$, $s(t) = 1$ on $(1 - \epsilon, 1]$, and s is a diffeomorphism on $[\epsilon, 1 - \epsilon]$. If F is any homotopy between f_0 and f_1 , then replace it by $\tilde{F}(p, t) = F(p, s(t))$. If a homotopy \tilde{F}' connects f_0 and f_1 , while \tilde{F}'' connects f_1 and f_2 , then set

$$\tilde{F}(p, t) = \tilde{F}'(p, 2t), \quad t \in [0, 1/2]$$

$$\tilde{F}(p, t) = \tilde{F}''(p, 2t - 1), \quad t \in [1/2, 1] .$$

It is a *smooth* homotopy between f_0 and f_2 . For isotopies and diffeotopies we argue similarly.

1.14. Linearization of diffeomorphisms of \mathbb{R}^n up to isotopy

We have

PROPOSITION 1.16. *Every diffeomorphism $f : \mathbb{R}^n \rightarrow \mathbb{R}^n$, $f(0) = 0$, is diffeotopic to the differential $d_0f \in \text{GL}(n, \mathbb{R})$, through diffeomorphisms f_t such that $f_t(0) = 0$ for every $t \in \mathbb{R}$.*

Proof : Define $F : \mathbb{R}^n \times \mathbb{R} \rightarrow \mathbb{R}^n$, by $F(x, t) = f(tx)/t$ if $t \neq 0$, $F(x, 0) = d_0f$. It follows from the very definition of the differential that F is continuous; clearly it is smooth where $t \neq 0$. To check that it is fully smooth we note that by the division theorem $F(x, t) = \sum_j g_j(y)x_j$, $y = tx$ the g_j being smooth maps of y . □

We can strenghten the above Proposition. Let us set $\text{GL}^\pm = \text{GL}^\pm(n, \mathbb{R})$ the open subsets of $\text{GL}(n, \mathbb{R})$ formed by the matrices A such that either $\det A > 0$ or $\det A < 0$. Take the identity I_n and the matrix $I_{n,1}$ (the notation has been introduced in the proof of Morse's Lemma) as base points of the two sets respectively. We have

THEOREM 1.17. *Every diffeomorphism $f : \mathbb{R}^n \rightarrow \mathbb{R}^n$, $f(0) = 0$, such that $d_0f \in \text{GL}^+$ (resp. $d_0f \in \text{GL}^-$) is diffeotopic to the linear isomorphism I_n (resp. $I_{n,1}$), through diffeomorphisms f_t such that $f_t(0) = 0$ for every $t \in \mathbb{R}$.*

Proof : If U is a connected open set of some \mathbb{R}^n , then it follows easily from the proof of Proposition 1.1 that any two points of U can be connected by a piecewise smooth path in U . In fact it is not hard to see that one can take a globally smooth path (use bump functions in order to get a smoothing). By using this remark, it is enough to prove that both open sets GL^\pm are connected. In fact it is enough to show that GL^+ is connected. For if $A \in \text{GL}^-$, then $I_{n,1}A$ is in GL^+ ; if A_t is a path connecting $I_{n,1}A$ with I_n in GL^+ , then $I_{n,1}A_t$ is a path connecting A and $I_{n,1}$ in GL^- .

Let us show first that there is a path B_t in GL^+ connecting any given $A = B_0$ with some $B = B_1$ which belongs to

$$\text{SO}(n) := \{P \in \text{GL}(n, \mathbb{R}); P^{-1} = P^t, \det P = 1\} .$$

Let $\langle *, * \rangle$ be the positive definite scalar product on \mathbb{R}^n determined by imposing that the ordered columns of A form an orthonormal basis \mathcal{B} of \mathbb{R}^n with respect to such a scalar product. Set

$$(*, *)_t = (1 - t) \langle *, * \rangle + t(*, *)$$

where $(*, *)$ is the standard euclidean scalar product, $t \in [0, 1]$. Then $(*, *)_t$ is a path of positive definite scalar products. For every $t \in [0, 1]$, apply the usual Gram-Schmidt orthogonalization algorithm to the basis \mathcal{B} that produces an orthonormal basis \mathcal{B}_t for $(*, *)_t$; by considering the ordered vectors of \mathcal{B}_t as columns of a matrix B_t , we eventually get a path of matrices such that $B_0 = A$ and $B_1 \in \text{SO}(n)$. It remains to show that every $B \in \text{SO}(n)$ can be connected to I_n by a path in $\text{SO}(n)$. Let us consider $B : \mathbb{R}^n \rightarrow \mathbb{R}^n$ as a linear isometry with respect to $(*, *)$. By linear algebra we know that \mathbb{R}^n can be decomposed as the orthogonal direct sum of B -invariant linear subspaces V_i of dimension either 1 or 2. In the first case the restriction of B to V_i is the identity; in the second case B acts on V_i as a rotation. Then we are reduced to prove that a rotation on \mathbb{R}^2 can be connected to I_2 by a path of rotations, and this is immediate. □

1.15. Homogeneity

We have

PROPOSITION 1.18. *Let $p, q \in \mathbb{R}^n$ such that $\|p - q\| = d > 0$. Then for every $\epsilon > 0$ there is a diffeomorphism $f : \mathbb{R}^n \rightarrow \mathbb{R}^n$ such that*

- (1) $f(p) = q$
- (2) f is diffeotopic to the identity of \mathbb{R}^n by a diffeotopy of compact support contained in $B^n(p, d + \epsilon)$.

Proof : In this proof we use some tools that will be developed in Chapter 7. Without the requirement about the supports the proof is immediate: set $v = q - p$, then $f_t(x) := x + tv$, $t \in \mathbb{R}$, $f = f_1$ verify the thesis. Note that for every $x \in \mathbb{R}^n$, $f_t(x)$ is the integral line defined on the whole real line of the vector field on \mathbb{R}^n constantly equal to v . Now we use a bump function to modify this vector field making it with compact support. Let $d + \epsilon/3 < a < b < d + \epsilon/2$, and consider the bump function $\gamma = \gamma_{p,a,b}$. Take the smooth vector field on \mathbb{R}^n defined by $\gamma(x)v$. For every $x \in \mathbb{R}^n$ there is a unique maximal parametrized integral curve denoted again $f_t(x)$ such that $f_0(x) = x$; as the field has compact support also in this case every $f_t(x)$ is defined on the whole real line. The $f_t(x)$ for $t \in [0, 1]$ realizes the required isotopy. □

The above proposition is a sort of local case of the following more general result

THEOREM 1.19. *Let $U \subset \mathbb{R}^n$ be a connected open set. Then for every $p \neq q \in U$ there is a diffeotopy F of U between $f_0 = \text{id}_U$ and $f = f_1$ such that $f(p) = q$, and F has compact support.*

Proof : The proof is qualitatively similar to the one of Proposition 1.1. Being ‘connected’ via a diffeotopy with compact support as in the statement of the theorem defines an equivalence relation on U . By applying Proposition 1.18 on a chart diffeomorphic to \mathbb{R}^n at every $p \in U$ we realize that every equivalence class is an open set, hence there is only one because U is connected. □

CHAPTER 2

The category of embedded smooth manifolds

Let us begin by widely extending the notions of smooth map and diffeomorphism to *arbitrary* topological subspaces of some \mathbb{R}^n , $n \in \mathbb{N}$.

Let $X \subset \mathbb{R}^n$, $Y \subset \mathbb{R}^m$ be arbitrary subspaces. Then $f : X \rightarrow Y$ is \mathcal{C}^k , $k \geq 0$, if for every $x \in X$ there exist an open neighbourhood U of x in \mathbb{R}^n and a map $g_U \in \mathcal{C}^k(U, \mathbb{R}^m)$ such that for every $y \in U$, $f(y) = g_U(y)$. Such a map g_U is called a *local \mathcal{C}^k extension of f at $x \in X$* .

f is \mathcal{C}^∞ (i.e. *smooth*) if for every $x \in X$ there are smooth local extensions of f at x .

A map $f : X \rightarrow Y$ is a *diffeomorphism* if it is a homeomorphism and both f and f^{-1} are smooth maps.

It is easy to verify by using the results of Chapter 1 that \mathcal{C}^k maps, smooth maps and diffeomorphisms are stable under composition of maps. By using this very general notion of diffeomorphism we can readily define embedded smooth manifolds.

DEFINITION 2.1. For every $0 \leq k \leq n$, a topological subspace $M \subset \mathbb{R}^n$ is an *embedded smooth k -manifold* (k is called the *dimension* of M) if for every $p \in M$, there exist an open neighbourhood W of p in M , an open set U of \mathbb{R}^k and a diffeomorphism $\phi : W \rightarrow U$.

Every such a (W, ϕ) is called a *chart* of M ; set $\psi = \phi^{-1}$, then (U, ψ) is called a *local parametrization* of M . The family of all charts is called *the atlas* $\mathcal{A} = \mathcal{A}_M$ of M . Hence by definition \mathcal{A} incorporates an open covering of M . An *atlas* $\mathcal{U} \subset \mathcal{A}$ of M is any family of charts that incorporates an open covering of M .

The *category of smooth embedded manifolds* has as *objects* the embedded smooth manifolds in some \mathbb{R}^n , $n \in \mathbb{N}$; the *morphisms* are the smooth maps between embedded smooth manifolds; the diffeomorphisms are the *equivalences* in the category.

2.1. Basic properties and examples

We are going to list a few basic examples or properties that follow immediately from the definitions or are consequence of results of Chapter 1.

- A 0-manifold in \mathbb{R}^n is a subset of isolated points. It is compact if and only if it is finite; otherwise it is countable.

- In order to show that $M \subset \mathbb{R}^m$ is a smooth manifold (sometimes we will omit to say “embedded”) it is enough to exhibit an atlas \mathcal{U} . The whole atlas \mathcal{A} is implicitly determined by \mathcal{U} . For example for every $(W, \phi) \in \mathcal{U}$, for every open subset $U' \subset U$, the restriction $(U', \phi' := \phi|_{U'})$ belongs to \mathcal{A} .

- Every open set $U \subset \mathbb{R}^n$ is a n -manifold: the inclusion $j : U \rightarrow \mathbb{R}^n$ forms an atlas of U with only one chart. Hence the category discussed in Chapter 1 is a subcategory of the present category. More generally an open set in a k -manifold M is also a k -manifold.

- Let U be an open set in \mathbb{R}^n , $f : U \rightarrow \mathbb{R}^m$ a smooth map. Then its *graph*

$$G(f) := \{(x, y) \in U \times \mathbb{R}^m; y = f(x)\}$$

is a n -smooth manifold embedded in \mathbb{R}^{n+m} . In fact $W = G(f) \cap (U \times \mathbb{R}^m) = G(f)$, $\phi : W \rightarrow U$, $\phi(x, f(x)) = x$ form an atlas of $G(f)$ with only one chart; the inverse parametrization is $\psi : U \rightarrow W$, $\psi(x) = (x, f(x))$.

- Let V be a linear (or affine) k -subspace of \mathbb{R}^n . It is a k -manifold, in fact the atlas \mathcal{A} contains any linear (affine) isomorphism $L : V \rightarrow \mathbb{R}^k$.
- Let $M \subset \mathbb{R}^m$, $N \subset \mathbb{R}^n$ be embedded smooth manifolds. Then the product $M \times N$ is a smooth manifold embedded into \mathbb{R}^{n+m} , and

$$\dim(M \times N) = \dim M + \dim N .$$

In fact if (W, ϕ) is a chart of M at p , (W', ϕ') of N at q , then $(W \times W', \phi \times \phi')$ is a chart of $M \times N$ at (p, q) .

- If $(W, \phi), (W', \phi') \in \mathcal{A}$ are charts of a k -manifold M , and $W \cap W' \neq \emptyset$, then

$$\beta_{W, W'} := \phi' \circ \psi : \tilde{U} \rightarrow \tilde{U}'$$

is a diffeomorphism between open sets of \mathbb{R}^k (that is $\tilde{U} = \phi(W \cap W') \subset U$ and $\tilde{U}' = \phi'(W \cap W') \subset U'$). It is called indifferently *change of charts* or *of local parametrizations* or also *of local coordinates*.

- If $f : M \rightarrow N$ is a smooth map between embedded smooth manifolds, (W, ϕ) is a chart of M , (W', ϕ') of N such that $f(W) \subset W'$, then

$$f_{U, U'} := \phi' \circ f \circ \psi : U \rightarrow U'$$

is a smooth map between open sets of euclidean spaces called a *representation of f in local coordinates* or shortly a *local representation of f* .

- *The dimension of embedded smooth manifolds is invariant up to diffeomorphism.* This follows immediately from the above items and the “invariance of dimension” already discussed in Chapter 1.

LEMMA 2.2. (1) *An embedded smooth k -manifold $M \subset \mathbb{R}^n$ is connected if and only if it is path connected.*

(2) *Every path connected component of M is a k -manifold. M is the disjoint union of its path connected (equivalently connected) components.*

Proof : It is a general topological fact that a path connected space is connected. For the other implication we can repeat the argument already used for the open sets in \mathbb{R}^k . In fact by using a chart around any point $p \in M$ we can argue that the path connected component of p is open in M , hence there is only one if M is connected. This proves (1) and also (2) indeed. □

The definition of embedded smooth manifold $M \subset \mathbb{R}^n$ implies some strong *local* constraint on the relative configuration of the pair (\mathbb{R}^n, M) . We have

LEMMA 2.3. *Let $M \subset \mathbb{R}^n$ be an embedded smooth k -manifold; $p \in M$. Then there exist a chart (Ω, β) of \mathbb{R}^n , $p \in \Omega$, such that $(\Omega \cap M, \beta|_M)$ is chart of M and moreover*

$$\beta(\Omega, \Omega \cap M, p) = (B^n(0, 1), B^n(0, 1) \cap \mathbb{R}^k, 0)$$

(where $\mathbb{R}^k \subset \mathbb{R}^k \times \mathbb{R}^{n-k} = \mathbb{R}^n$ as usual). Such a β is called a *relative normal chart of the pair (\mathbb{R}^n, M)* .

Proof : It follows immediately from the definition of embedded manifold that there exist an open neighbourhood Ω of p in \mathbb{R}^n , an open set U of \mathbb{R}^k , and an *injective immersion* $\psi : U \rightarrow \Omega$, such that $\psi(U) = \Omega \cap M := W$. By Theorem 1.3 on local normal form of immersions, possibly by shrinking Ω , there is chart (Ω, β) of \mathbb{R}^n that verifies the statement of the Lemma. □

The above argument can be somehow reversed.

LEMMA 2.4. *Let U be an open set of \mathbb{R}^k , $\psi : U \rightarrow \mathbb{R}^n$ be an injective immersion such that $\psi : U \rightarrow \psi(U)$ is a homeomorphism. Then $M = \psi(U)$ is a smooth manifold embedded in \mathbb{R}^n , and $\psi : U \rightarrow M$ is a (global) smooth parametrization of M .*

Proof : By using again Theorem 1.3 and the fact that f is a homeomorphism onto its image, we readily see that at every $p \in M$ one can find relative normal charts of (\mathbb{R}^n, M) , and eventually ψ is a diffeomorphism onto M . □

The condition that ψ is a homeomorphism onto its image is *necessary* as it is shown by the following example:

EXAMPLE 2.5. Consider the smooth map

$$E : \mathbb{R}^2 \rightarrow \mathbb{R}^2 \times \mathbb{R}^2, E(x, y) = (\cos(2\pi x), \sin(2\pi x), \cos(2\pi y), \sin(2\pi y)) .$$

For every $a \in \mathbb{R}$, $a \neq 0$, consider the map

$$f : \mathbb{R} \rightarrow \mathbb{R}^2 \times \mathbb{R}^2, f(x) = E(x, ax) .$$

This is an injective immersion but if a is *not a rational number*, then it is not a homeomorphism onto its image in $S^1 \times S^1$. In fact one can verify that $f(\mathbb{R})$ is *dense* in $S^1 \times S^1$ (every non empty open set of $S^1 \times S^1$ intersects $f(\mathbb{R})$), hence $f(\mathbb{R})$ is not an embedded manifold in $\mathbb{R}^2 \times \mathbb{R}^2$.

Submanifolds. If $Y \subset M$ are embedded smooth manifolds in \mathbb{R}^n , we say that Y is a *submanifold* of M . In particular both Y and M are submanifolds of \mathbb{R}^n . By extending the argument of Lemma 13.4.1 (details are left as an exercise) we can prove

LEMMA 2.6. *Let Y be a submanifold of $M \subset \mathbb{R}^n$, of dimension k and m respectively. Let $p \in Y$. Then there exist relative normal charts (for triples)*

$$\beta : (\Omega, \Omega \cap M, \Omega \cap Y, p) \rightarrow (B^n(0, 1), B^n(0, 1) \cap \mathbb{R}^m, B^n(0, 1) \cap \mathbb{R}^k, 0)$$

where as usual we consider $\mathbb{R}^m = \mathbb{R}^k \times \mathbb{R}^{m-k}$, $\mathbb{R}^n = \mathbb{R}^m \times \mathbb{R}^{n-m}$.

By using the immersions, we have indicated above a way to get embedded manifolds (endowed with global smooth parametrizations). Now we show how embedded manifolds can be defined *implicitly*.

LEMMA 2.7. *If $f : U \rightarrow W$ is a surjective smooth summersion between open sets of euclidean spaces, $U \subset \mathbb{R}^n$, $W \subset \mathbb{R}^m$. Then for every $q \in W$, $M = f^{-1}(q)$ is an embedded smooth manifold in \mathbb{R}^n and $\dim M = n - m$.*

Proof : Being an embedded manifold is a local property. Hence the lemma is an immediate consequence of Theorem 1.4 on local normal form of summersions or (equivalently) of the implicit function Theorem 1.6. □

REMARK 2.8. In spite of the existence of relative normal charts at every point of a submanifold, the relative position of two submanifolds of some \mathbb{R}^n can look stranger than one could expect. This is mainly due to the fact that submanifolds are not necessarily closed subsets. Consider for example the map $f : (0, +\infty) \rightarrow \mathbb{C} \sim \mathbb{R}^2$

$$f(x) = \frac{x}{1+x} e^{ix} .$$

This is an immersion and a homeomorphism onto its image say N . Then the unitary circle S^1 and N are disjoint 1-submanifolds of \mathbb{R}^2 . Nevertheless, two points $p \in S^1$ and $q \in N$ cannot be separated by normal charts of S^1 and N at p and q respectively. In other words $N \cup S^1$ is not an embedded submanifold.

EXAMPLE 2.9. (*Spheres*) Let us show, in several ways, that the unitary sphere $S^n \subset \mathbb{R}^{n+1}$, $n \in \mathbb{N}$, is an embedded smooth n -manifold. Let $\mathbb{R}^{n+1} = \mathbb{R}^n \times \mathbb{R}$. Let $W^+ = S^n \setminus \{e_{n+1}\}$, $\phi_+ : W^+ \rightarrow \mathbb{R}^n$ be the *stereographic projection* with center e_{n+1} . It is defined geometrically by $\phi_+(x) = r(x, e_{n+1}) \cap \mathbb{R}^n$ where $r(x, e_{n+1})$ is the straight line passing through the two points. Analytically we have

$$\phi_+(x) = \frac{1}{1 - x_n}(x_1, \dots, x_{n-1}) .$$

This is a diffeomorphism onto \mathbb{R}^n with inverse given by

$$\psi_+(y) = \left(\frac{2y}{1 + \|y\|^2}, \frac{\|y\|^2 - 1}{\|y\|^2 + 1} \right) .$$

Then (W^+, ϕ_+) is a chart of S^n at every points different from e_{n+1} . By using the similar projection with center $-e_{n+1}$, we get a chart (W^-, ϕ_-) which misses only $-e_{n+1}$. Hence $\{(W^\pm, \phi_\pm)\}$ is an atlas of S^n (formed by two charts).

For every $p \in S^n$, let p^\perp the subspace of \mathbb{R}^{n+1} orthogonal to p . Then by using the projection of $S^n \setminus \{p\}$ onto p^\perp with center p (followed by any linear chart of p^\perp onto \mathbb{R}^n) then we obtain other charts of the atlas \mathcal{A}_{S^n} .

Further charts are obtained as graphs of functions defined on the unitary open disk of p^\perp with center p . The basic example for $p = e_{n+1}$ is the function $h : B^n \rightarrow \mathbb{R}$,

$$h(x) = \sqrt{1 - \sum_{i=1}^{n-1} x_i^2} .$$

$S^n = f^{-1}(1)$, where $f : \mathbb{R}^{n+1} \setminus \{0\} \rightarrow \mathbb{R}$, $f(x) = \|x\|^2$. As $df_x = (2x_1, \dots, 2x_{n+1})$ then f is a summersion and this implies again (implicitly) that S^n is a n -manifold by Lemma 2.7.

S^n is a *compact* manifold. In fact it is closed because $S^n = f^{-1}(1)$ as above; obviously it is bounded.

S^n is path connected: given $x \neq y \in S^n$, let P be the 2-plane spanned by these two vectors. Then $P \cap S^n$ is a maximal circle, x, y separate it into two arcs both connecting x and y .

Important examples of embedded smooth manifolds (widely generalizing the spheres) are discussed in Chapter 3.

2.2. The embedded tangent functor

Let us fix a setting we will refer to all along the rest of this Chapter.

- $M \subset \mathbb{R}^h$ is an embedded smooth manifold of dimension m , $p \in M$; $N \subset \mathbb{R}^k$ is an embedded smooth manifold of dimension n , $q \in N$;
- $f : M \rightarrow N$ is a smooth map, $f(p) = q$.
- $\phi : W \rightarrow U \subset \mathbb{R}^h$ is a chart of M at p , $\phi(p) = a$, with inverse local parametrization $\psi : U \rightarrow W \subset M$.
- $f_{U,U'} : U \rightarrow U'$ is a representation of f in local coordinates at p ; recall that this is obtained as follow: we take a local chart of M at p for simplicity still denoted (W, ϕ) , and a local chart (W', ϕ') of N at q , $\phi'(q) = b$, such that $f(W) \subset W'$; then

$$f_{U,U'} = \phi' \circ f \circ \psi : U \rightarrow U'$$

(U and U' being open set of \mathbb{R}^h and \mathbb{R}^k respectively).

- Possibly by shrinking W we can also assume that there are an open neighbourhood Ω of p in \mathbb{R}^h such that $\Omega \cap M = W$, a local smooth extension $\Phi : \Omega \rightarrow \mathbb{R}^m$ of ϕ and a local smooth extension $F : \Omega \rightarrow \mathbb{R}^k$ of f .

The facts collected in the following Lemma are easy consequences of the very definitions and of the results of Chapter 1. The reader would like to make the useful exercise to fill the details.

LEMMA 2.10. (1) *The differential $d_a\psi$ is injective so it is a linear isomorphism onto its image $d_a\psi(\mathbb{R}^m)$, $\mathbb{R}^m = T_aU$, which is a m -linear subspace of $\mathbb{R}^h = T_p\mathbb{R}^h$. This image does not depend on the choice of the local parametrization ψ of M at p . Hence*

$$T_pM = d_a\psi(\mathbb{R}^m)$$

is well defined and is called the tangent space to M at the point p .

(2) *The restriction of the differential $d_p\Phi$ to T_pM is the inverse isomorphism $(d_a\psi)^{-1}$. Hence it does not depend on the choice of the local extension Φ of ϕ , and*

$$d_p\phi := d_p\Phi|_{T_pM}$$

is a well defined linear isomorphism

$$d_p\phi : T_pM \rightarrow T_aU .$$

(3) *The restriction of d_pF to T_pM does not depend on the choice of the local extension of f and is valued in T_qN . Hence it is well defined*

$$d_p f := d_p F|_{T_p M}$$

it is a linear map

$$d_p f : T_p M \rightarrow T_q N$$

and is called the differential of f at p . We have

$$d_a f_{U,U'} = d_q \phi' \circ d_p f \circ d_a \psi : T_a U \rightarrow T_b U'$$

and this is the representation in local coordinates of $d_p f$. In particular this applies when $M = W$, and $f = \phi' : W \rightarrow U' \subset \mathbb{R}^m$ is another chart of M at p .

(4) *If $g \circ f$ is a composition of smooth maps between embedded smooth manifolds, $f(p) = q$, then*

$$d_p(g \circ f) = d_q g \circ d_p f .$$

If f is a diffeomorphism, then $d_p f$ is a linear isomorphism and $d_q f^{-1} = (d_p f)^{-1}$. If $f = \text{id}$, then $d_p f = \text{id}_{T_p M}$.

(5) *If $M = G(g)$ is the graph of a smooth map $g : U \rightarrow \mathbb{R}^s$ defined on an open set $U \subset \mathbb{R}^m$, then*

$$T_{(x,g(x))}M = G(d_x g) .$$

(6) *If $M = g^{-1}(q)$, where $g : \Omega \rightarrow \mathbb{R}^s$ is a submersion, $p \in M$, then*

$$T_p M = \ker d_p g .$$

□

Set

$$T(M) = \{(x, v) \in \mathbb{R}^h \times \mathbb{R}^h; x \in M, v \in T_x M\} .$$

The restriction of the projection of $\mathbb{R}^h \times \mathbb{R}^h$ onto the first factor \mathbb{R}^h defines a smooth projection

$$\pi_M : T(M) \rightarrow M .$$

EXAMPLE 2.11.

$$T(S^n) = \{(x, v) \in \mathbb{R}^{n+1} \times \mathbb{R}^{n+1}; x \in S^n, v \in x^\perp\}$$

Check it!

As a set $T(M) = \cup_{x \in M} T_x M$. Note that for every open set $W \subset M$, $T(W)$ coincides with $\pi_M^{-1}(W)$, it is naturally included in $T(M)$ as an open set, and $\pi_W = (\pi_M)|_{T(W)}$.

We are going to show that

$T(M)$ is an embedded smooth manifold of dimension $2m$, of a special nature indeed.

Every chart $\phi : W \rightarrow U \subset \mathbb{R}^m$ of M can be enhanced to a chart

$$T\phi : T(W) \rightarrow T(U) = U \times \mathbb{R}^m, \quad T\phi(x, v) := (\phi(x), d_x\phi(v)) .$$

The inverse parametrization is

$$T\psi : U \times \mathbb{R}^m \rightarrow T(W), \quad T\psi(y, w) = (\psi(y), d_y\psi(w)) .$$

If π_U is the natural projection onto U , it is immediate that the following diagram denoted $[\psi, T\psi]$ commutes

$$\begin{array}{ccc} U \times \mathbb{R}^m & \xrightarrow{T\psi} & T(W) \\ \downarrow \pi_U & & \downarrow \pi_W \\ U & \xrightarrow{\psi} & W \end{array}$$

We say that $\pi_M : T(M) \rightarrow M$ is *locally trivial* (a *product*) over W and that the above diagram is a *local trivialization*. By varying the chart (W, ϕ) in the atlas \mathcal{A} of M we get an atlas

$$T\mathcal{A} = \{(T(W), T\phi)\}$$

of $T(M)$. The local coordinates for $T\mathcal{A}$ changes in a special way as they are of the form

$$T\beta := T\phi' \circ T\psi : \tilde{U} \times \mathbb{R}^m \rightarrow \tilde{U}' \times \mathbb{R}^m$$

$$T\beta(x, v) = (\phi' \circ \psi(x), d_x(\phi' \circ \psi)(v)) = (\beta(x), d_x\beta(v)) .$$

Hence, for every x varying in M , it is a linear isomorphism on the second argument which “varies smoothly” with the point x . This means that

The intrinsic linear structure of every fibre $T_x M = \pi_M^{-1}(x)$ of the projection π_M is respected by the changes of coordinates for the atlas $T\mathcal{A}$.

We can encode the same information by lifting $T\mathcal{A}$ at the level of the open covering $\{W\}$ of M ; that is we have the locally trivializing commutative diagrams

$$\begin{array}{ccc} W \times \mathbb{R}^m & \xrightarrow{\tilde{T}\psi} & T(W) \\ \downarrow \pi_W & & \downarrow \pi_W \\ W & \xrightarrow{\text{id}_W} & W \end{array}$$

where

$$\tilde{T}\psi = T\psi \circ (\phi, \text{id}_{\mathbb{R}^m}) .$$

Any change of local trivialization for $\tilde{T}\mathcal{A}$ is of the form

$$\tilde{T}\beta : (W \cap W') \times \mathbb{R}^m \rightarrow (W \cap W') \times \mathbb{R}^m, \quad (x, v) \rightarrow (x, d_x\beta(v)) .$$

We summarize all these facts by saying that

$$\pi_M : T(M) \rightarrow M$$

is the *tangent vector bundle* of the embedded smooth manifold M and that $T\mathcal{A}$ (actually and equivalently $\tilde{T}\mathcal{A}$) is its *vector bundle atlas*.

In section 2.6 we will formalize these notions in a more general setting.

Now we extend the definition of the *tangent map* already considered in Chapter 1 in the case of open sets in some \mathbb{R}^n . Let $f : M \rightarrow N$ be our smooth map between embedded smooth manifolds, then set:

$$Tf : T(M) \rightarrow T(N), \quad Tf(x, v) = (f(x), d_x f(v)) .$$

Note that the defining inclusion $T(M) \subset \mathbb{R}^h \times \mathbb{R}^h = T(\mathbb{R}^h)$ is nothing else than Tj , $j : M \rightarrow \mathbb{R}^h$ being the inclusion. Clearly the following diagram, denoted $[f, Tf]$, commutes

$$\begin{array}{ccc} T(M) & \xrightarrow{Tf} & T(N) \\ \downarrow \pi_M & & \downarrow \pi_N \\ M & \xrightarrow{f} & N \end{array}$$

that is Tf sends every fibre $T_x M$ linearly to the fibre $T_{f(x)} N$, by a ‘smooth field’ of linear maps.

If $g \circ f$ is a composition of smooth maps between embedded smooth manifolds, then

$$\begin{aligned} T(g \circ f) &= Tg \circ Tf \\ \text{Tid}_M &= \text{id}_{T(M)} \end{aligned}$$

if f is a diffeomorphism, then Tf is a diffeomorphism and

$$Tf^{-1} = (Tf)^{-1} .$$

All verifications are local and follows immediately from Lemma 2.10 and the properties of the tangent map in the category of open sets in euclidean spaces.

We can summarize these considerations as follows:

The tangent category of the category of embedded smooth manifolds has as objects the tangent vector bundles of embedded smooth manifolds and as morphisms the tangent maps of smooth maps between embedded smooth manifolds. Then

$$\begin{aligned} M &\Rightarrow \pi_M : T(M) \rightarrow M \\ f : M \rightarrow N &\Rightarrow [f, Tf] \end{aligned}$$

define a covariant functor from the category of embedded smooth manifolds to its tangent category.

2.3. Immersions, summersions, embeddings, Monge charts

The notions of immersion and summersion extend immediately to map between embedded smooth manifolds: $f : M \rightarrow N$ is an *immersion* (resp. *summersion*) if for every $x \in M$, $d_x f$ is *injective* (*surjective*). We say that $f : M \rightarrow N$ is an *embedding* if f is a diffeomorphism onto its image (in particular the inclusion $M \subset \mathbb{R}^h$ is an embedding). The proof of the following proposition is of local nature and follows from Lemmas 5.2 and 2.7.

PROPOSITION 2.12. (1) *Let $f : M \rightarrow N$ be a surjective summersion; then for every $q \in N$, $Y = f^{-1}(q)$ is a submanifold of M , $\dim Y = \dim M - \dim N$.*

(2) *If $f : M \rightarrow N$ is an embedding then $f(M)$ is a submanifold of N .*

(3) *$f : M \rightarrow N$ is an embedding if and only if f is an immersion and a homeomorphism onto its image.*

(4) *If $f : M \rightarrow N$ is both an immersion and a summersion, then it is a local diffeomorphism.*

□

We have seen in example 2.9 a distinguished local graph chart of S^n . Here we show that such a kind of charts exists for every embedded smooth m -manifold $M \subset \mathbb{R}^h$ at every point. For every multi-index $J = (j_1, \dots, j_m)$, $|J| = m$, let J' ,

$|J'| = h - m$ be its complementary multi-index. Denote by \mathbb{R}_J the subspace of \mathbb{R}^h generated by $(e_{j_1}, \dots, e_{j_m})$; hence we have the orthogonal direct sum decomposition $\mathbb{R}^h = \mathbb{R}_J \oplus \mathbb{R}_{J'}$ and the orthogonal projection onto \mathbb{R}_J , $\pi_J(x) = (x_{j_1}, \dots, x_{j_m})$. For every $p \in M$, denote by $\pi_{J,p} : \mathbb{R}^h \rightarrow \mathbb{R}_J$ the composition of the translation $x \rightarrow x - p$, followed by π_J . Denote by $\phi_{J,p}$ the restriction of $\pi_{J,p}$ to (any suitable subset of) M . We have

PROPOSITION 2.13. (Monge charts) *For every embedded smooth m -manifold $M \subset \mathbb{R}^h$, for every $p \in M$, there exist J , $|J| = m$, and an open neighbourhood W of p in M such that $(W, \phi_{J,p})$ is a chart of M at p . The inverse local parametrization is of the form $\psi_{J,p} : U \rightarrow W$, $U \subset \mathbb{R}_J$, $\psi_{J,p}(y) = (y, f_{J,p}(y))$ (by using the above decomposition $\mathbb{R}^h = \mathbb{R}_J \oplus \mathbb{R}_{J'}$). Hence at every point p , M is locally a graph of a smooth function defined on some \mathbb{R}_J .*

Proof : By elementary linear algebra, there exist J such that the restriction of π_J to $T_p M$ is a linear isomorphism onto \mathbb{R}_J . As $d_p \phi_{J,p}$ coincides with such a restriction, then $\phi_{J,p}$ is a local diffeomorphism. \square

2.4. Topologies on spaces of smooth maps

Let $M \subset \mathbb{R}^h$, $N \subset \mathbb{R}^k$ be smooth manifolds as usual. We define the *weak topology* on every set $\mathcal{C}^r(M, N)$, $r \geq 0$, the topological spaces $\mathcal{E}^r(M, N)$ (subspaces of $\mathcal{C}^r(M, N)$ formed by the smooth maps) and the space $\mathcal{E}(M, N)$ that is $\mathcal{C}^\infty(M, N)$ equipped with the union of the \mathcal{E}^r topologies. This extends the case of open sets treated in Chapter 1 which is actually used in order to do it. There are two equivalent ways; both determine a basis of open neighbourhoods of every element in the pertinent map space. We leave to the reader the verification that the two topologies defined in these ways actually are the same one.

(1) For every $f \in \mathcal{C}^r(M, N)$ we consider neighbourhoods of the following form

$$\mathcal{U}_r(f, \hat{f}, K, \epsilon)$$

where

- $\hat{f} : \Omega \rightarrow \mathbb{R}^k$ is a local \mathcal{C}^r extension of $f|_W : W \rightarrow N$, $W = \Omega \cap M$, $\Omega \subset \mathbb{R}^h$ being open;
- $K \subset W$ is a compact set;
- $\epsilon > 0$.

Then $g \in \mathcal{C}^r(M, N)$ belongs to $\mathcal{U}_r(f, \hat{f}, K, \epsilon)$ if and only if there exists a \mathcal{C}^r extension $\hat{g} : \Omega \rightarrow \mathbb{R}^k$ of $g|_W$ such that $\hat{g} \in \mathcal{U}_r(\hat{f}, K, \epsilon) \subset \mathcal{C}^r(\Omega, \mathbb{R}^k)$.

(2) For every $f \in \mathcal{C}^r(M, N)$ we consider neighbourhoods of the following form

$$\mathcal{U}_r(f, f_{U,U'}, K, \epsilon)$$

where

- $f_{U,U'} : U' \rightarrow U$ is a (necessarily \mathcal{C}^r) representation of f in local coordinates ($U \subset \mathbb{R}^m$, $U' \subset \mathbb{R}^n$ being open sets);
- $K \subset U$ is a compact set;
- $\epsilon > 0$.

Then $g \in \mathcal{C}^r(M, N)$ belongs to

$$\mathcal{U}_r(f, f_{U,U'}, K, \epsilon)$$

if and only if it admits a local representation (over the same open sets U, U') $g_{U,U'} : U \rightarrow U'$ such that $g_{U,U'} \in \mathcal{U}_r(f_{U,U'}, K, \epsilon) \subset \mathcal{C}^k(U, U')$.

2.5. Homotopy, isotopy, diffeotopy, homogeneity

These notions already introduced in Chapter 1 within the smooth category of open sets, extend *verbatim* to embedded smooth manifolds. They correspond to continuous paths in appropriate map spaces and bring equivalence relations along.

The proof of the homogeneity Theorem 1.19 is essentially of local nature, and extends straightforwardly.

THEOREM 2.14. *Let N be a connected embedded smooth manifold. Let $p, q \in N$. Then there is a diffeotopy with compact support between $f_0 = \text{id}_N$ and $f = f_1$ such that $f(p) = q$.*

□

2.6. Embedded fibre bundles

The tangent vector bundle is a first fundamental example of the general notion of *fibre bundle*. We will encounter several instances of all along this text. Chapter 4 will develop this topic. Here we state the basic facts.

An *embedded smooth fibre bundle* with *base space* X , *total space* E and *fibre* F , is a surjective summersion $f : E \rightarrow X$ between embedded smooth manifolds such that every fibre $f^{-1}(q)$, $q \in X$, is a submanifold of E diffeomorphic to a given manifold F , and which is *locally trivial(izable)* at every point q of X . This means that for every $q \in X$, there is a open neighbourhood Ω in X and trivializing commutative diagram of the form

$$\begin{array}{ccc} \Omega \times F & \xrightarrow{\Phi} & \tilde{\Omega} \\ \downarrow \pi_\Omega & & \downarrow f| \\ \Omega & \xrightarrow{\text{id}_\Omega} & \Omega \end{array}$$

where $\tilde{\Omega} := f^{-1}(\Omega)$, Φ is a diffeomorphism (with inverse say Ψ). If $E = X \times F$ and $f = \pi_X$ is the natural projection then it is a *trivial* (also called ‘product’) fibre bundle. The family of all *local trivializations* as above form the *maximal fibred atlas* \mathcal{F} of the fibre bundle. A fibred atlas is a subfamily of \mathcal{F} such that the Ω ’s form an open covering of X , hence the $\tilde{\Omega}$ ’s of E . Every fibred atlas is contained in a unique maximal one, so it is enough to give a fibred atlas in order to determine a fibre bundle structure. Every change of local trivialization is of the form

$$\begin{aligned} \Phi' \circ \Psi : (\Omega \cap \Omega') \times F &\rightarrow (\Omega \cap \Omega') \times F \\ (p, y) &\rightarrow (p, \rho(p)(y)) \end{aligned}$$

where $\rho(p)$ belongs to the group $\text{Aut}(F)$ of the smooth automorphisms of the fibre F .

- In many cases the fibre F has an additional structure which is preserved by a subgroup G of $\text{Aut}(F)$ (for example F is a linear subspace of some \mathbb{R}^n and $G = \text{GL}(F)$); if the $\rho(p)$ ’s as above belong to G then we have a *G-fibre bundle* (*vector bundle*, ...).

- A particular case is when $\dim F = 0$. In such a case a fibration $f : E \rightarrow X$ is also called a *covering map* (of *degree* d if F is compact hence finite, and $d = |F|$). For every local trivialization, the restriction of f to every connected component of $\tilde{\Omega}$ is a diffeomorphism onto Ω , provided that Ω is connected.

- A *fibred map* between fibre bundles is a commutative diagram of smooth maps $[g, \tilde{g}]$ of the form

$$\begin{array}{ccc} E & \xrightarrow{\tilde{g}} & E' \\ \downarrow f & & \downarrow f' \\ X & \xrightarrow{g} & X' \end{array}$$

so that every fibre $E_x \sim F$ is mapped to the fibre $E'_{g(x)} \sim F'$. It is a *fibred diffeomorphism* if both g and \tilde{g} are diffeomorphisms. In such a case $F = F'$. The diagrams $[f, Tf]$ of the tangent functor are basic examples of fibred maps.

Fibred equivalences. Consider the set $\mathcal{F}(X, F)$ of fibred bundles over a given base space X , with given fibre F . There are two natural equivalence relations on $\mathcal{F}(X, F)$:

(1) The *full equivalence*: it is generated by the fibred diffeomorphisms $[g, \tilde{g}]$ such that g belongs to the group $\text{Aut}(X)$ of smooth automorphisms of X .

(2) The *strict equivalence* (often we will omit to say “strict”): it is generated by the fibred diffeomorphism of the form $[\text{id}_X, \tilde{g}]$.

This specializes directly to the case of G -fibred bundles.

2.7. Tensor functors

Let us recall some elementary facts of finite dimensional *multi-linear algebra*. Every finite dimensional real vector space V has an infinite family of associated *tensor spaces* $T_q^p(V)$, $p, q \in \mathbb{N}$ - also denoted $(V)^{\otimes p} \otimes (V^*)^{\otimes q}$ - formed by the multilinear forms

$$\alpha : \prod_{i=1}^p V^* \times \prod_{j=1}^q V \rightarrow \mathbb{R} .$$

Hence the *dual space* $V^* = T_1^0(V)$, while V is “equal” to $T_0^1(V)$ via the canonical identification of V with its *bidual space* $(V^*)^*$. If $\dim V = m$, then

$$\dim T_q^p(V) = m^{pq} .$$

Moreover, to every basis \mathcal{B} of V , we can associate in a canonical way a basis \mathcal{B}_q^p of $T_q^p(V)$, we can say that the basis \mathcal{B} “propagates” to every tensor space. The linear group $\text{GL}(V)$ acts on $T_q^p(V)$ by

$$(g, \alpha) \rightarrow g(\alpha)$$

$$g(\alpha)(w^1, \dots, w^p, v_1, \dots, v_q) = \alpha((g^t)^{-1}(w^1), \dots, (g^t)^{-1}(w^p), g(v_1), \dots, g(v_q)) .$$

By applying this to $V = \mathbb{R}^m$ (endowed with the canonical basis \mathcal{C}) and to $T_q^p(\mathbb{R}^m)$ (with the canonical basis \mathcal{C}_q^p) we get a homomorphism of group (that is a *representation*)

$$\rho_{p,q} : \text{GL}(m, \mathbb{R}) \rightarrow \text{GL}(T_q^p(\mathbb{R}^m)) \sim \text{GL}(m^{pq}, \mathbb{R})$$

which is an explicit *regular rational* map. The basic example is

$$\rho_{0,1}(A) = (A^t)^{-1} .$$

As another example: $T_2^0(\mathbb{R}^m)$ can be identified with $M(m, \mathbb{R})$ by associating to every matrix B the form

$$(v, w) \rightarrow v^t B w .$$

Then

$$\rho_{0,2}(P)(B) = P^t B P .$$

In some case it is interesting to consider suitable subspaces W of $T_q^p(V)$, $\dim W = w$ say, which are invariant for the action of $\text{GL}(V)$ and are endowed as well with a basis \mathcal{B}_W canonically associated to \mathcal{B} . By applying this to $V = \mathbb{R}^m$, this gives rise to other representations

$$\rho_W : \text{GL}(m, \mathbb{R}) \rightarrow \text{GL}(W) \sim \text{GL}(w, \mathbb{R}) .$$

For example consider the subspace $W = S_0^2(V) \subset T_2^0(V)$ of *symmetric bilinear form* on $V \times V$ (i.e. the space of *scalar products* on V). In this case the representation ρ_W is just the “restriction” of $\rho_{0,2}$. Another example is the subspace $\Lambda_q^0(V) \subset T_q^0(V)$ of

alternating multilinear forms. As a particular case $\Lambda_m^0(\mathbb{R}^m)$ is 1-dimensional with canonical basis

$$\det : M(m, \mathbb{R}) \rightarrow \mathbb{R}, \quad X \rightarrow \det(X)$$

considered as m -linear function of the columns of X . This gives rise to the representation

$$\delta_m : \mathrm{GL}(m, \mathbb{R}) \rightarrow \mathrm{GL}(1, \mathbb{R}), \quad \delta_m(P) = \det P .$$

We are going to show that for every embedded smooth m -manifold $M \subset \mathbb{R}^h$, the tangent vector bundle

$$\pi = \pi_M : T(M) \rightarrow M$$

has naturally associated a family of further embedded vector bundles over M

$$\pi_{p,q} = \pi_{p,q,M} : T_q^p(M) \rightarrow M$$

such that for every $x \in M$, $\pi_{p,q}^{-1}(x) = T_q^p(T_x M)$, and clearly $T(M) = T_0^1(M)$.

Let us start with the *cotangent bundle*

$$T^*(M) := T_1^0(M) .$$

Recall that $(\mathbb{R}^h)^* = M(h, 1, \mathbb{R}) \sim \mathbb{R}^h$. For every $x \in M$, denote by V_x the orthogonal complement of $T_x M$ in \mathbb{R}^h , so that we have the orthogonal direct sum decomposition $\mathbb{R}^h = T_x M \oplus V_x$. For every functional $\gamma \in T_x^* M$, extend it to a functional on the whole of \mathbb{R}^h by imposing that $\gamma(v+w) = \gamma(v)$ for every $w \in V_x$. In this way we have identified $T_x^* M$ as a linear subspace of $(\mathbb{R}^h)^*$. For every open subset $U \subset \mathbb{R}^m$, the cotangent bundle is the product bundle $U \times (\mathbb{R}^m)^* \rightarrow U$. By copying the definition of the tangent bundle, set

$$T^*(M) = \{(x, \gamma) \in \mathbb{R}^h \times (\mathbb{R}^h)^*; x \in M, \gamma \in T_x^* M\}$$

endowed with the natural projection

$$\pi_M^* : T^*(M) \rightarrow M .$$

For every open set $W \in M$, $T^*(W) = (\pi_M^*)^{-1}(W)$, it is an open set of $T^*(M)$ and π_W^* is the restriction of π_M^* . We define the vector bundle atlas $T^* \mathcal{A}$ of $T^*(M)$; for every chart (W, ϕ) of M with inverse local parametrization ψ , set $(T^*(W), T^* \phi)$,

$$T^* \phi : T^*(W) \rightarrow U \times (\mathbb{R}^m)^*, \quad (x, \gamma) \rightarrow (\phi(x), \gamma \circ d_{\psi(x)}) .$$

The changes of local (fibred) coordinates for $T^* \mathcal{A}$ are of the form

$$\begin{aligned} T^* \beta : \tilde{U} \times (\mathbb{R}^m)^* &\rightarrow \tilde{U}' \times (\mathbb{R}^m)^* \\ T^* \beta(x, \gamma) &= (\beta(x), \rho_{0,1}(d_x \beta)(\gamma)) . \end{aligned}$$

If $f : M \rightarrow N$ is a *diffeomorphism*, we define

$$T^* f : T^*(N) \rightarrow T^*(M), \quad (y, \gamma) \rightarrow (f^{-1}(y), \gamma \circ d_{f^{-1}(y)})$$

Then

$$\begin{aligned} M &\Rightarrow \pi_M^* : T^*(M) \rightarrow M \\ f : M &\rightarrow N \Rightarrow [f, T^* f] \end{aligned}$$

define the *contravariant cotangent functor* from the *restricted category of embedded smooth manifolds* to its *cotangent category* ('restricted' means that only the diffeomorphisms are allowed as morphisms). To get a covariant version of the same functor it is enough to replace $T^* f$ with $T^*(f^{-1})$.

(*The T_2^0 functor*) For every $x \in M$, identify $T_2^0(T_x M)$ as a subspace of $T_2^0(\mathbb{R}^h)$ by extending every bilinear form α over $T_x M$ to a bilinear form over the whole of \mathbb{R}^h by imposing that for every $v+w, u+z \in T_x M \oplus V_x$, $\alpha(v+w, u+z) = \alpha(v, u)$. By the usual scheme, set

$$\begin{aligned} T_2^0(M) &= \{(x, \alpha) \in \mathbb{R}^h \times T_2^0(\mathbb{R}^m); x \in M, \alpha \in T_2^0(T_x M)\} \\ \pi_{0,2,M} : T_2^0(M) &\rightarrow M \end{aligned}$$

the natural projection. We have the vector bundle atlas $T_2^0\mathcal{A}$ obtained by associating to every chart (W, ϕ) of M , with inverse local parametrization ψ , the chart $(T_2^0(W), T_2^0\phi)$

$$T_2^0\phi(x, \alpha) = (\phi(x), \alpha \circ (d_x\psi \times d_x\psi)) .$$

The changes of coordinates for $T_2^0\mathcal{A}$ are of the form

$$T^*\beta(x, \alpha) = (\beta(x), \rho_{0,2}(d_x\beta)(\alpha)) .$$

If $f : M \rightarrow N$ is a diffeomorphism, we can define

$$T_2^0f : T_2^0(N) \rightarrow T_2^0(M)$$

$$T_2^0f(y, \alpha) = (f^{-1}(y), \alpha \circ (d_{f^{-1}(y)}f \times d_{f^{-1}(y)}f)) .$$

This leads to the contravariant functor defined on the restricted category of embedded smooth manifolds:

$$M \Rightarrow \pi_{0,2,M} : T_2^0(M) \rightarrow M$$

$$f : M \rightarrow N \Rightarrow [f, T_2^0f] .$$

As above we can obtain a covariant version by replacing T_2^0f with $T_2^0(f^{-1})$.

(*The T_q^p functors*) The construction of $T := T_0^1$, $T^* := T_1^0$, T_2^0 functors can be generalized straightforwardly (with the same formal features) to every (p, q) , getting the *tensorial functors*

$$M \Rightarrow \pi_{p,q,M} : T_q^p(M) \rightarrow M$$

$$f : M \rightarrow N \Rightarrow [f, T_q^p f]$$

where we can stipulate to take always the covariant version (and we refer to the restricted smooth category when necessary).

(*The determinant bundle*) By using the spaces $\Lambda_m^0(T_x M)$ we get the determinant bundle of M (with 1-dimensional fibre)

$$\delta_M : \det T(M) \rightarrow M$$

with changes of $\det T\mathcal{A}$ coordinates

$$\det T\beta(x, r) = (\beta(x), (\det d_x\beta)r) .$$

2.8. Tensor fields, unitary tensor bundles

We can extend and generalize the content of section 1.5 of Chapter 1 to embedded smooth manifolds.

Let $\pi : E(M) \rightarrow M$ be any tensor vector bundle as above, with fibre $E_x M$ over $x \in M$ of dimension say r . A *section* of this bundle is a smooth map

$$\sigma : M \rightarrow E(M)$$

such that for every $x \in M$, $\pi(\sigma(x)) = x$. In other words σ determines a smooth *field of tensors* of a certain type on M . Denote by

$$\Gamma(E(M))$$

the set of these sections. As for every vector bundle, every $\Gamma(E(M))$ has a canonical *zero section*

$$\sigma_0(x) = (x, 0), \quad x \in M .$$

In this way M is canonically included into $E(M)$. Every $\Gamma(E(M))$ is a module over the commutative ring $\mathcal{C}^\infty(M, \mathbb{R})$, hence a real vector space.

- An element of $\Gamma(T(M))$ is called a *vector field* on M . Generalizing verbatim section 1.10, $\Gamma(T(M))$ is isomorphic to the vector space of *derivations* on $\mathcal{C}^\infty(M, \mathbb{R})$, $\text{Der}(\mathcal{C}^\infty(M, \mathbb{R}))$.

- An element in $\Gamma(T^*(M))$ is called a 1-*differential form* on M . If $f : M \rightarrow \mathbb{R}$ is a smooth function, then $df \in \Gamma(T^*(M))$.

- A section $g \in \Gamma(S_2^0(M))$ such that $g(x)$ is positive definite for every $x \in M$ is called a *riemannian metric* on M . Every M admits riemannian metrics: for every riemannian metric \hat{g} on \mathbb{R}^h (for instance the standard g_0), then the restriction of \hat{g}_x to $T_x M$ for every $x \in M$ defines a riemannian metric g on M .

$f : (M, g) \rightarrow (N, g')$ is an *isometry* if it is a diffeomorphism and for every $x \in M$, $v, w \in T_x M$, then $g_x(v, w) = g'_{f(x)}(d_x f(v), d_x f(w))$.

If (W, ϕ) is a chart of (M, g) , with inverse parametrization $\psi : U \rightarrow W$, then by imposing that ψ is tautologically an isometry we get a representation g_U of g in local coordinates; g_U is an instance of riemannian metric on the open set $U \subset \mathbb{R}^m$ as defined in Chapter 1.

- Given a riemannian metric g on M , for every smooth function $f : M \rightarrow \mathbb{R}$ there is a unique vector field $\nabla_g f$ (called the *gradient of f with respect to g*) such that for every $x \in M$, every $v \in T_x M$,

$$d_x f(v) = g_x(\nabla_g f(x), v) .$$

- (*Other functors*) By setting

$$M \Rightarrow \Gamma(T^*(M))$$

$$f : M \rightarrow N \Rightarrow f^* : \Gamma(T^*(N)) \rightarrow \Gamma(T^*(M))$$

where

$$f^*(\omega)(x)(v) = \omega(f(x))(d_x f(v))$$

ones defines a contravariant functor from the category of embedded smooth manifolds to the category of real vector spaces.

By allowing only the diffeomorphisms as morphisms, then by setting

$$M \Rightarrow \Gamma(T(M))$$

$$f : M \rightarrow N \Rightarrow f_* : \Gamma(T(M)) \rightarrow \Gamma(T(N))$$

where

$$f_*(X)(y) := d_{f^{-1}(y)}(X(f^{-1}(y)))$$

one defines a covariant functor from the ‘restricted’ category of embedded smooth manifolds to the category of real vector spaces.

- Let (W, ϕ) and (U, ψ) be chart/parametrization of M as above, then for every $X \in \Gamma(T(M))$, every $\omega \in \Gamma(T^*(M))$, by using either ϕ_* or ψ^* we get local representations in the coordinates of U of the type described in section 1.5. Representations in local coordinates can be straightforwardly developed for every field of tensors of arbitrary type on M .

2.8.1. Unitary tensor bundles. Let (M, g) be endowed with the riemannian metric restriction of the standard metric g_0 on \mathbb{R}^h . Set

$$UT(M) = \{(x, v) \in T(U); \|v\|_{g_x} = 1\}$$

with the restriction

$$u\pi_M : UT(M) \rightarrow M$$

of $\pi_M : T(M) \rightarrow M$. Then $UT(M)$ is a submanifold of $T(M)$ of dimension $m(m-1)$, and $u\pi_M$ is a surjective summersion with every fibre diffeomorphic (isometric

indeed) to the unitary sphere S^{m-1} . More precisely, the local trivializations of $T(M)$,

$$\begin{array}{ccc} U \times \mathbb{R}^m & \xrightarrow{T\phi} & T(W) \\ \downarrow \pi_U & & \downarrow \pi_W \\ U & \xrightarrow{\phi} & W \end{array}$$

restrict to “unitary” local trivializations

$$\begin{array}{ccc} U \times S^{m-1} & \xrightarrow{UT\phi} & UT(W) \\ \downarrow \pi_U & & \downarrow u\pi_W \\ U & \xrightarrow{\phi} & W \end{array}$$

Then $u\pi_M : UT(M) \rightarrow M$ is called the *unitarity tangent bundle of M* .

Let $\pi : E(M) \rightarrow M$ be as before any of our tensor bundles. For every $x \in M$, the positive scalar product g_x on every $T_x M$ canonically propagates to a positive definite scalar product g_x^E on the fibre $E_x M$; this is defined as follows: given one g_x -*orthonormal* basis \mathcal{B}_x of $T_x M$, g_x^E is determined by imposing that the basis \mathcal{B}_x^E of $E_x M$ canonically associated to \mathcal{B}_x is g_x^E -*orthonormal* (one verifies that this does not depend on the choice of the basis \mathcal{B}_x). Then by the very same procedure we get the *unitary tensor bundle*

$$u\pi : UE(M) \rightarrow M$$

with fibre isometric to the unitary sphere S^{r-1} .

REMARK 2.15. We have defined the unitary tangent bundle (and its relatives) by using the restriction of the standard riemannian metric on the ambient euclidean space. However, if $f : M \rightarrow M$ is a diffeomorphism then in general the unitary tangent bundle is *not* preserved; moreover the construction of a unitary tangent bundle works as well if M is endowed with an arbitrary riemannian metric; *from a differential topological view point, there is not a privileged riemannian metric*. So we dispose indeed of an infinite family of unitary bundles. The total spaces of two unitary bundle defined with respect to two metrics g_0 and g_1 are canonically diffeomorphic via radial diffeomorphisms fibre by fibre, centred at the origine of each $T_x M$. Moreover by using the path of riemannian metrics $g_t = (1-t)g_0 + tg_1$ this diffeomorphism is connected to the identity by a smooth path (an *isotopy*) through diffeomorphisms of unitary bundles of the same type. This considerations “propagate” to all tensor bundles. Every unitary tensor bundle is well defined up to isotopy.

2.9. Parallelizable, combable and orientable manifolds

An embedded smooth manifold $M \subset \mathbb{R}^h$ of dimension $m \geq 1$ is said *parallelizable* if there are m sections $\Sigma = (\sigma_1, \dots, \sigma_m) \in \Gamma(T(M))^m$ such that for every $x \in M$, $\Sigma(x)$ is a basis of $T_x M$. This property “propagates” to every of our favourite tensor bundles say $\pi : E(M) \rightarrow M$ with fibres $E_x M$ of dimension say r . In fact for every (p, q) , the canonical correspondence $\Sigma(x) \rightarrow \Sigma(x)_q^p$ determines

$$\Sigma_q^p \in \Gamma(T_q^p(M))^{m^{pq}}$$

such that for every $x \in M$, $\Sigma(x)_q^p$ is a basis of $T_q^p(T_x M)$; similarly we have a *nowhere vanishing* section $\det \Sigma$ of the determinant bundle $\delta_M : \det(T(M)) \rightarrow M$. In generical notations, denote $\Sigma \in \Gamma(E(M))^r$ such a distinguished field of bases. We can define

$$t_\Sigma : M \times \mathbb{R}^r \rightarrow E(M), \quad t_\Sigma(x, v) = \left(x, \sum_j v_j \sigma_j(x)\right)$$

clearly this is a diffeomorphism and also a vector bundle map in the sense that for every $x \in M$, it induces a *linear isomorphism* $\{x\} \times \mathbb{R}^r \rightarrow E_x M$. Moreover the following diagram obviously commutes

$$\begin{array}{ccc} M \times \mathbb{R}^r & \xrightarrow{t_\Sigma} & E(M) \\ \downarrow p_M & & \downarrow \pi \\ M & \xrightarrow{\text{id}_M} & M \end{array}$$

Then t_Σ is called a *global trivialization of the bundle* $E(M)$.

So M is parallelizable if and only if its tangent bundle is strictly equivalent to a product bundle, and a *necessary* condition in order that M is parallelizable is that the determinant bundle of M has a nowhere vanishing section. Let us say that M is *orientable* if it verifies such a necessary condition. Obviously, if M is parallelizable, then it is “*combable*”, that is it carries a nowhere vanishing tangent vector field. Every open set of \mathbb{R}^n is parallelizable, hence orientable and combable. The same facts hold *locally* on every manifold M . So we have here a bunch of crucial genuine global questions concerning the structure of a generic smooth manifold M in terms of the existence of suitable patterns of sections of natural fibre bundles over M .

Let us explicate now the definition of orientability. It is clear that M is orientable if and only if every connected component of M is orientable; so let us assume that M is connected. Consider the *unitary* determinant bundle. The fibre is $S^0 = \{\pm 1\}$, so we can write it as

$$\mathfrak{p} : \tilde{M} \rightarrow M$$

where \tilde{M} is a m -manifold, \mathfrak{p} is a covering map of degree 2 called the *orientation covering of* M . The fibre over every $x \in M$ is $\{(x, \pm 1)\}$. There are two possibilities: either \tilde{M} is connected or it has two connected components

$$\tilde{M} = \tilde{M}_+ \cup \tilde{M}_-$$

where

$$\tilde{M}_\pm = \{(x, \pm 1); x \in M\}.$$

Obviously the restriction of \mathfrak{p} to \tilde{M}_\pm is a diffeomorphism (basically it is the identity). If $x \rightarrow (x, \sigma(x))$ is a nowhere vanishing section of the determinant bundle, as M is connected the sign $\frac{\sigma(x)}{\|\sigma(x)\|_{g(x)}}$ is constant. So we have proved

PROPOSITION 2.16. *M is orientable if and only if $\tilde{M} = \tilde{M}_+ \cup \tilde{M}_-$ is not connected.*

EXAMPLE 2.17. Referring to section 3.4, examples of *connected* $\mathfrak{p} : \tilde{M} \rightarrow M$ are the natural covering maps

$$S^n \rightarrow \mathbf{P}^n(\mathbb{R})$$

when n is *even*. Then such projective spaces are not orientable.

The alternative “ M orientable/non-orientable” can be reformulated as follows: a *signature* \mathfrak{s} on an atlas \mathcal{U} of M assign to every chart a sign $\mathfrak{s}(W, \phi) = \pm 1$. Given such an \mathfrak{s} , modify \mathcal{U} to $\mathcal{U}_\mathfrak{s}$ by post composing every chart with negative sign with a linear reflection of \mathbb{R}^m (which has the determinant equal to -1). An atlas \mathcal{U} is *oriented* if all changes of coordinates for \mathcal{U} have the determinant sign constantly equal to 1. Then we have

PROPOSITION 2.18. *The following facts are equivalent to each other:*

- (1) M is orientable;
- (2) There exists an oriented atlas \mathcal{U} of M ;
- (3) For every atlas \mathcal{U} of M there exists a signature \mathfrak{s} such that $\mathcal{U}_\mathfrak{s}$ is oriented.

We leave the proof to the reader as an useful exercise on this complex of definitions. The condition of point (2) in the Proposition is often given as the *very definition of orientability*. A reader can do it without effecting the rest of our discussions. Here is some further remarks on these notions.

- If M is connected and orientable, then every oriented atlas \mathcal{U} is contained in an unique maximal oriented atlas. There are exactly two maximal oriented atlas say \mathcal{A}^\pm . Any signature \mathfrak{s} on \mathcal{A} such that $\mathcal{A}_\mathfrak{s}$ is oriented produces one among \mathcal{A}^\pm ; \mathfrak{s} produces \mathcal{A}^+ if and only if the opposite signature $-\mathfrak{s}$ produces \mathcal{A}^- . By definition \mathcal{A}^\pm define two opposite *orientations* of M and make it (in two ways) an *oriented* manifold. If M is oriented, \tilde{M} denotes M endowed with the opposite orientation. The two components of \tilde{M} are naturally oriented and correspond to the two orientations of M .

- The definition via oriented atlas allows us to recover the elementary notion of orientation of \mathbb{R}^m as a vector space. By definition two bases \mathcal{B} and \mathcal{D} of \mathbb{R}^m are *co-oriented* if the determinant of the change of linear coordinates passing from \mathcal{B} to \mathcal{D} is positive. By the multiplicative properties of the determinant, this defines an *equivalence relation* on $\text{GL}(m, \mathbb{R})$ (considered as the space of bases of \mathbb{R}^m); then an *orientation* on \mathbb{R}^m is an equivalence class of bases. Let us call *standard orientation* the class $[\mathcal{C}]$ of the canonical basis \mathcal{C} . If U is a (connected) open set of \mathbb{R}^m we get the *standard field of orientations* by giving each $T_x U = \mathbb{R}^m$ the standard orientation. U is obviously an orientable manifold and we can take the maximal oriented atlas say \mathcal{A}^+ of U which contains the chart $\text{id} : U \rightarrow U$. Let $\psi : U' \rightarrow U'' \subset U$ the local parametrization associated to a chart of \mathcal{A}^+ . By taking the standard field of orientations on U' , $d\psi$ transforms it to the field of orientations $\{[d_y \phi(\mathcal{C})]\}_{x=\psi(y)}$ on U'' . The fact that ψ belongs to \mathcal{A}^+ just means that this last field coincides with the standard one on U'' . Extending this considerations to an arbitrary manifolds M , an orientation on M , if any, can be considered as a “locally coherent” field of orientations on each $T_x M$.

- Let $f : M \rightarrow N$ be a diffeomorphism. If $\mathcal{U} = \{(W, \phi)\}$ is an atlas of M , then

$$f(\mathcal{U}) := \{(f(W), \phi \circ f^{-1})\}$$

is an atlas of N . The proof of the following Lemma follows immediately from the definitions.

LEMMA 2.19. *Let $f : M \rightarrow N$ be a diffeomorphism between connected oriented manifolds with maximal oriented atlas say \mathcal{A}_M^+ and \mathcal{A}_N^+ respectively. The following facts are equivalent to each other.*

- (1) $f(\mathcal{A}_M^+) = \mathcal{A}_N^+$.
- (2) *There exist an oriented atlas $\mathcal{U} \subset \mathcal{A}_M^+$ such that $f(\mathcal{U}) \subset \mathcal{A}_N^+$.*
- (3) *For every representation in local coordinates $f_{U,U'} : U \rightarrow U'$ of f relative to charts in \mathcal{A}_M^+ and \mathcal{A}_N^+ and for every $x \in U$, then $\det d_x f_{U,U'} > 0$.*

If one (hence all) of the above conditions is verified, then we say that f is an oriented diffeomorphism.

- By specializing the *objects* to oriented manifolds we get a sub-category of our favourite one.

REMARK 2.20. (*Oriented 0-Manifolds*) A 0-manifold is a discrete set of points, hence just one point if connected. We stipulate that it is orientable and is *oriented* by giving it a sign ± 1 .

2.10. Manifolds with boundary, oriented boundary, proper submanifolds

By definition an embedded smooth m -manifold $M \subset \mathbb{R}^n$ is locally diffeomorphic to open sets of the basic model \mathbb{R}^m . Let us change this last by taking instead the *half-space*

$$\mathbf{H}^m = \{x \in \mathbb{R}^m; x_m \geq 0\}$$

with the *boundary*

$$\partial\mathbf{H}^m = \{x \in \mathbf{H}^m; x_m = 0\}.$$

DEFINITION 2.21. For every $0 \leq m \leq n$, a topological subspace $M \subset \mathbb{R}^n$ is an *embedded smooth m -manifold with boundary* if for every $p \in M$, there exist an open neighbourhood W of p in M , an open set U of \mathbf{H}^m and a diffeomorphism $\phi : W \rightarrow U$. The notions of “chart”, “local parametrization”, “atlas” extend straightforwardly. By definition, the *boundary* ∂M is the set of points $p \in M$ such that there exists a chart (W, ϕ) at p such that $\phi(p) \in \partial\mathbf{H}^m$.

The following Lemma provides a basic way to produce manifolds with boundary.

LEMMA 2.22. *Let X be a m -manifold with empty boundary, $f : X \rightarrow J$ a surjective summersion, where J is an open interval of \mathbb{R} , and $0 \in J$. Then $M = \{x \in X; f(x) \geq 0\}$ is a m -manifold with boundary $\partial M = \{f(x) = 0\}$.*

Proof : The question being of local nature one can reduce to summersions in normal form for which the result is evident. □

The following Lemma contains by the way an extension of Lemma 13.4.1 and similarly is an application of the inverse map theorem (and its corollaries).

LEMMA 2.23. *Let $M \subset \mathbb{R}^n$ be an m -manifold with boundary. Then*

- (1) *If $p \in \partial M$, then for every chart (W, ϕ) of M at p , $\phi(p) \in \partial\mathbf{H}^m$.*
- (2) *$\text{Int}(M) := M \setminus \partial M$ is an open set in M and a manifold with empty boundary (called the interior of M). For every $p \in \text{Int}(M)$ there are normal relative charts of $(\mathbb{R}^n, \text{Int}(M))$ at p that do not intersect ∂M .*
- (3) *For every $p \in \partial M$, there are normal relative charts of $(\mathbb{R}^n, M, \partial M)$ at p :*

$$\beta : (\Omega, \Omega \cap M, \Omega \cap \partial M, p) \rightarrow (B^n(0, 1), B^n(0, 1) \cap \mathbf{H}^m, B^n(0, 1) \cap \partial\mathbf{H}^m, 0)$$
- (4) *If $\partial M \neq \emptyset$, then it is $(m - 1)$ -manifold with empty boundary.*

□

The definition of “embedded smooth manifold with boundary” does not exclude that $\partial M = \emptyset$. We have early considered such a *boundaryless* case. It is formally convenient to stipulate that the empty set \emptyset is a k -boundaryless manifold for every $k \in \mathbb{N}$. In such a way for example point (4) of the last Lemma holds even if $\partial M = \emptyset$. By setting $M = (M, \emptyset)$ for every boundaryless manifold, the early category of *embedded smooth manifolds* extends to the category of *embedded smooth manifolds with boundary*. Let us briefly retrace within such an extension the main facts developed so far .

- The tangent functor and its relatives extend verbatim. If ∂M is non empty, the inclusion $j : \partial M \rightarrow M$ leads to a vector bundle embedding $[j, Tj]$ of $\pi_{\partial M} : T(\partial M) \rightarrow \partial M$ into $\pi_M : T(M) \rightarrow M$. The total space $T(M)$ is a manifold with boundary equal to the restriction over ∂M of the tangent bundle of M (with the notions that we will introduce in Chapert 4 it is the pull-back $j^*T(M)$ over ∂M). Similarly for the other tensors bundles.

- Also “orientability/orientation” extends directly. The boundary ∂M of an *oriented M* is *orientable* and we can fix the following procedure in order to make it the *oriented boundary* of M :

(“*First the outgoing normal*”) Take an oriented atlas \mathcal{U} of M made by normal charts. Post compose every chart along the boundary ∂M with a transformation $r \in SO(m)$ such that $r(e_1, \dots, e_m) = (-e_m, r(e_1, \dots, e_{m-1}))$. The so obtained atlas, say $r\mathcal{U}$ is again an oriented atlas of M and its restriction to ∂M is an oriented atlas which carries a determined orientation of the boundary.

By the usual convention $M = (M, \emptyset)$, the category of *oriented* boundaryless manifolds extends to the category of *oriented* manifolds with oriented boundary.

• (*Submanifolds*) Alike the boundaryless case, let us stipulate that if $Y, M \subset \mathbb{R}^n$ are embedded smooth manifolds with boundary and $Y \subset M$, then Y is a *submanifold* of M . By extending the Remark 2.8, because of the presence of the boundary there are several qualitatively different ways of being a submanifold; let us list a few examples:

- (1) $(Y \subset M) = (\overline{B}^n(0, 1) \subset B^n(0, 2))$: $\partial Y \neq \emptyset$ and Y is contained in the interior of M .
- (2) $(Y \subset M) = (\text{Int}(M) \subset M)$; if $\partial M \neq \emptyset$, then Y is not closed in M .
- (3) $(Y \subset M) = (N \subset B^n(0, 1))$, where N is defined in Remark 2.8: Y is boundaryless, is contained in the interior of M , and every point of ∂M is in the closure of Y ; again Y is not closed in M .
- (4) $(Y \subset M)$ where $Y = \overline{B}^n(0, 1)$, $M = \{x_n \geq -1\}$. Then ∂Y is tangent to ∂M , while the interior of Y is contained in the interior of M .
- (5) Let $\gamma := \gamma_{1,2} : \mathbb{R} \rightarrow \mathbb{R}$ the bump function defined in Chapter 1. $(Y \subset M) = (N \subset \mathbf{H}^2)$, where $N = \{(x, y) \in \mathbf{H}^2; y \geq \gamma(x)\}$. Then ∂Y is partially contained in the interior of M , partially into ∂M .
- (6) ...

Among this wide typology there is a particularly clean type which deserves to be pointed out by a definition.

DEFINITION 2.24. Let $Y \subset M \subset \mathbb{R}^n$ smooth manifolds with boundary. Then Y is a *proper submanifold* of M if

- (1) Y is closed in M ;
- (2) $\partial Y = Y \cap \partial M$;
- (3) Y is *transverse* to ∂M . This means that for every $p \in Y \cap \partial M$

$$T_p M = T_p Y + T_p \partial M .$$

All the above examples are not proper. Every M is a proper submanifold of itself. The properness implies for instance that every boundaryless component of Y is contained in the interior of M ; if $\partial M = \emptyset$, then also $\partial Y = \emptyset$; if $\dim Y = \dim M$ then Y is union of connected components of M .

The following Proposition extends (1) of Proposition 2.12 in two ways, to manifolds with boundary and to oriented manifolds.

PROPOSITION 2.25. *Let M be a manifold with boundary and N a boundaryless one. Let $f : M \rightarrow N$ be a surjective relative summersion (that is both f and $\partial f := f|_{\partial M}$ are summersions). Then:*

- (1) *For every $q \in N$, $Y = f^{-1}(q)$ is a proper submanifold of M , $\dim Y = \dim M - \dim N$.*
- (2) *If both M and N are oriented, then Y is orientable, and we can fix a procedure to orient it, in such a way that the orientation of ∂Y as oriented boundary of Y coincides with the orientation obtained by applying the procedure to ∂f , provided that ∂M is the oriented boundary of M .*

Proof: Assume that $M \subset \mathbb{R}^h$, $\dim M = m$, $\dim N = n$. If q does not belong to the image of ∂f , then we apply directly Proposition 2.12 so that Y is a closed boundaryless submanifold of the interior of M . Assume now that q belongs to the image

of ∂f . The question being of local nature, we reduce to analyze a representation (called f as well) of f in local coordinates which are normal for $(M, \partial M)$:

$$f : (B^m(0, 1) \cap \mathbf{H}^m, B^m(0, 1) \cap \partial\mathbf{H}^m) \rightarrow U \subset \mathbb{R}^n$$

$q = 0 \in U$. Moreover we can assume that f is the restriction of a smooth map $g : B^m(0, 1) \rightarrow U$ defined on the whole of $B^m(0, 1)$, which is a surjective summersion. By applying again Proposition 2.12 to g , we have that $\tilde{Y} = g^{-1}(0)$ is a boundaryless submanifold of $B^m(0, 1)$ of the correct dimension, such that $Y = f^{-1}(0)$ is $Y = \tilde{Y} \cap \mathbf{H}^m$. As f is a relative summersion, one readily checks that \tilde{Y} is transverse to $\partial\mathbf{H}^m$ and that the restriction say π to \tilde{Y} of the projection onto the x_m coordinate is a summersion onto its image and that $Y = \{y \in \tilde{Y}; \pi(y) \geq 0\}$. We conclude by applying Lemma 2.22.

Let us come to the orientation. First consider the case $f = \text{id}_M$. Then $Y = \{p\}$ is just a point of M . Let us orient it by giving it the sign $+1$. By applying the rule to ∂f we get the same sign. In the general case. For every $p \in Y$ let

$$\nu(p) = (T_p Y)^\perp \cap T_p M$$

clearly

$$T_p(M) = T_p Y \oplus \nu(p)$$

and $\nu(p)$ varies “smoothly” when p varies along Y (by using the contents of next Chapter 4 this means precisely that $\nu : Y \rightarrow \mathfrak{G}_{k,n}$ is a smooth map). In our hypotheses, for every $p \in Y$, the restriction of $d_p f$ to $\nu(p)$ is a linear isomorphism onto $T_{f(p)}N$. Let us consider the orientation on N as a field of orientations on the $T_y N$, $y \in N$, (i.e. a field of equivalence classes of bases of $T_y N$) which is locally coherent). Take an orienting (say “positive”) basis \mathcal{B}_q of $T_q N$. For every $p \in Y$, lift it to a basis \mathcal{B}_p of $\nu(p)$ by means of the restriction of the differential of f . This determines a field of “transverse orientations” $[\mathcal{B}_p]$ along Y . At every p , take a basis \mathcal{D}_p of $T_p Y$ such that the basis $\mathcal{D}_p \oplus \mathcal{B}_p$ of $T_p M$ (compatible with the above direct sum decomposition of $T_p M$) is positive with respect to the given orientation of M . This determines a field $[\mathcal{D}_p]$ of orientations on the $T_p Y$, eventually the desired orientation of Y . This procedure could be finalized in terms of the construction of a suitable oriented atlas for Y ; we leave it to the reader. One can check that the restriction of this procedure to ∂f is compatible in the sense of the last statement of the proposition. □

• Also the *topologies* of spaces of smooth maps between manifolds with boundary extend word by word.

2.11. Product, manifolds with corners, smoothing

We know that the product of two boundaryless manifolds is a boundaryless manifold. The situation is more complicated if we consider non empty boundaries. The following Lemma is immediate.

LEMMA 2.26. *Let M be a boundaryless (embedded smooth) m -manifold, N be a n -manifold with $\partial N \neq \emptyset$. Then $M \times N$ is a $(m+n)$ -manifold with $\partial(M \times N) = M \times \partial N$* □

However, if both ∂M and ∂N are non empty, then $M \times N$ is no longer an embedded smooth manifold with boundary.

EXAMPLE 2.27. As a basic example, consider the square

$$Q = D_1 \times D_2 := [-1, 1] \times [-1, 1] \subset \mathbb{R}^2 .$$

Its topological frontier is

$$\partial Q = (\partial D_1 \times D_2) \cup (D_1 \times \partial D_2) ;$$

its interior

$$Q \setminus \partial Q = \text{Int}(D_1) \times \text{Int}(D_2)$$

is an open set of \mathbb{R}^2 hence a 2-manifold with empty boundary;

$$Q \setminus (\partial D_1 \times \partial D_2)$$

is a 2-manifold with boundary equal to

$$\partial Q \setminus (\partial D_1 \times \partial D_2) ;$$

$\partial D_1 \times \partial D_2$ is a 0-manifold. The points where Q fails to be a manifold with boundary are the “corner” points which form $\partial D_1 \times \partial D_2$.

The behaviour of such a simplest example is qualitatively the general one:

PROPOSITION 2.28. *Let $(M, \partial M) \subset \mathbb{R}^h$ and $(N, \partial N) \subset \mathbb{R}^k$ be an m -manifold and an n -manifold with boundary respectively. Then $M \times N \subset \mathbb{R}^h \times \mathbb{R}^k$ verifies the following properties:*

- *Set*

$$\partial(M \times N) := (\partial M \times N) \cup (M \times \partial N) .$$

Then

$$(M \times N) \setminus \partial(M \times N)$$

is a boundaryless $(m + n)$ -manifold;

-

$$(M \times N) \setminus (\partial M \times \partial N)$$

is a $(m + n)$ -manifold with boundary equal to

$$\partial(M \times N) \setminus (\partial M \times \partial N) ;$$

- *$\partial M \times \partial N$ is a boundaryless $(m + n - 2)$ -manifold.*

□

Hence $M \times N$ fails to be a manifold with boundary at the “corner locus” $\partial M \times \partial N$. This means that the category of embedded smooth manifolds with boundary is *not closed* with respect to the product. This is somehow unpleasant. A way to fix this fact is to enlarge our category by extending the sets of basic models, incorporating the corners. We do it in the minimal way suited to incorporate such product manifolds.

DEFINITION 2.29. The *basic m -corner models* is

$$\mathbf{C}^m = \{x \in \mathbb{R}^m; x_m \geq 0, x_{m-1} \geq 0\}$$

that is the intersection between \mathbf{H}^m with another halfspace. Its *boundary* (in fact its topological frontier) is

$$\partial \mathbf{C}^m = \{x \in \mathbf{C}^m; x_m = 0\} \cup \{x \in \mathbf{C}^m; x_{m-1} = 0\} .$$

$\mathbf{C}^m \setminus \{x_m = 0, x_{m-1} = 0\}$ is a manifold with boundary and the last set is its *corner locus*.

DEFINITION 2.30. For every $0 \leq m \leq n$, a topological subspace $M \subset \mathbb{R}^n$ is an *embedded smooth m -manifold with corners* if for every $p \in M$, there exist an open neighbourhood W of p in M , an open set U of \mathbf{C}^m and a diffeomorphism $\phi : W \rightarrow U$. The notions of “chart”, “local parametrization”, “atlas” extend straightforwardly. The *boundary* ∂M is the set of points $p \in M$ such that there exists a chart (W, ϕ) at p such that $\phi(p) \in \partial \mathbf{C}^m$. The *corner locus* is where M is not locally a smooth manifold with boundary.

The following properties clearly hold for the basic models and descend easily to every manifold with corners.

(i) Every manifold with corners is naturally *stratified* by means of the disjoint locally finite union of boundaryless connected smooth manifolds (of varying dimension $m-2 \leq d \leq m$) called the *strata*; the top dimensional strata are the components of the boundaryless smooth m -manifold $M \setminus \partial M$; the $(m-1)$ -strata are the components of ∂M from which we have removed the corner locus; the $(m-2)$ -strata are the components of the corner locus which is a boundaryless manifold of dimension $m-2$ contained in the boundary of M . The closure of every stratum is union of strata, as well as the maximal smooth manifold with boundary contained in the closure of every stratum.

(ii) The product of two smooth manifolds with boundary is a manifold with corners.

However, manifolds with “codimension 2” corners are not closed under the product (take for instance the cube $[-1, 1]^3$). So we have only shifted the difficulty and we should extend furthermore our category of manifolds. This would bring us a bit far away from our original objects of interests. Fortunately there is another way that leads back manifolds with corners (according with the above restrictive definition) to ordinary manifolds with boundary, even though *up to diffeomorphism*. To introduce such a “*smoothing the corner*” procedure, let us consider again our simplest square example. The function

$$f : \mathbb{R}^2 \rightarrow, f(x) = (x_1 - 1)(x_2 - 1)(x_1 + 1)(x_2 + 1)$$

has the property that Q is the closure of a connected component of

$$\mathbb{R}^2 \setminus f^{-1}(0)$$

and for every $x \in \text{int}(Q)$, $f(x) > 0$. For every $\epsilon > 0$, sufficiently small, there is a connected component Q_ϵ of $f(x) \geq \epsilon$ contained in the interior of Q , and which is a smooth manifold with boundary *homeomorphic* to Q . Moreover, we can construct a “piece-wise smooth” radial homeomorphism (centred at 0) $s : Q_\epsilon \rightarrow Q$ such that the natural stratification of Q lifts to a stratification by smooth submanifolds of Q_ϵ and the restriction to the maximal manifold with boundary contained in the closure of every stratum is a diffeomorphism onto its analogous image in Q . Finally, up to diffeomorphism, the result of such a smoothing does not depend on the specific implementation (in particular on the choice of the small ϵ).

This basic idea can be generalized. By applying it to \mathbf{C}^m , by using $M_\epsilon = \{x_m x_{m-1} \geq \epsilon\} \cap \mathbf{C}^m$, $\epsilon > 0$ small enough, we get nice local smoothing homeomorphism $s : M_\epsilon \rightarrow \mathbf{C}^m$ with the same qualitative properties as above. Then one should have to prove that such local smoothings can be patched to give a global smooth atlas. This could be a bit technically demanding (with simplifications if the manifolds are compact) and we do not further push in that direction. In Section 7.3 we will reconsider and properly establish such a smoothing procedure in a more flexible “abstract” setting. Anyway we already state the following

PROPOSITION 2.31. *For every m -manifold with corner $M \subset \mathbb{R}^h$, then*

(1) *by implementing a determined “smoothing the corner” procedure, we get a smooth manifold with boundary $\tilde{M} \subset \mathbb{R}^h$ and a piece-wise smooth homeomorphism*

$$\mathfrak{s} : (\tilde{M}, \partial\tilde{M}) \rightarrow (M, \partial M)$$

such that the natural stratification of M lifts to a stratification of \tilde{M} by boundaryless smooth submanifolds, and the restriction of \mathfrak{s} to the maximal smooth manifold with boundary contained in the closure of every stratum of \tilde{M} is a diffeomorphism onto its analogous image in M .

(2) \tilde{M} is uniquely determined up to diffeomorphism (i.e. it does not depend on the actual implementation of the procedure).

□

Coming back to our motivating problem, the product of two smooth manifolds with boundary as a smooth manifold with boundary is well defined *up to diffeomorphism*.

Stiefel and Grassmann manifolds

The tensorial vector bundles constructed in Chapter 2 belong to a wide category of “embedded vector bundles” that we will consider in Chapter 4; the core of that discussion will consist in remarkable families of embedded smooth manifolds and smooth maps between them that we are going to study by themselves.

3.1. Stiefel manifolds

We introduce first the *Stiefel manifolds*. There are two versions that we call *linear* and *orthogonal* respectively. For every $n \in \mathbb{N}$ and every $0 \leq k \leq n$, the *linear Stiefel manifold* $L_{n,k}$, as a *set*, is the set of ordered k -uple (v_1, \dots, v_k) of linearly independent vectors in \mathbb{R}^n . By arranging each of them in a $n \times k$ matrix A (so that v_j is the j -column of A), $L_{n,k} \subset M(n, k, \mathbb{R})$. In fact it is *an open subset*: consider the smooth function $\delta : M(n, k, \mathbb{R}) \rightarrow \mathbb{R}$ defined in the proof of Proposition 20.1.6, then $L_{n,k} = M(n, k, \mathbb{R}) \setminus \delta^{-1}(0)$. This specifies the embedded smooth manifold nature of $L_{n,k}$. As a particular case we have $\text{GL}(n, \mathbb{R}) = L_{n,n}$. For every $P \in \text{GL}(n, \mathbb{R})$, $A \rightarrow PA$ defines a diffeomorphism (restriction of a linear map) $L_{n,k} \rightarrow L_{n,k}$, and it is well known that this action is transitive; in particular for every $A \in L_{n,k}$, there exists $P \in \text{GL}(n, \mathbb{R})$ such that $PI_{n,k} = A$ where $I_{n,k}$ is the matrix whose columns are e_1, \dots, e_k , the first k vectors of the canonical basis of \mathbb{R}^n .

Now, let $S_{n,k} \subset L_{n,k}$ be the closed subset defined as $f^{-1}(I_k)$ where

$$f : L_{n,k} \rightarrow S(k, \mathbb{R})$$

is the smooth map $f(A) = A^t A$ with values in the space $S(k, \mathbb{R})$ of $k \times k$ *symmetric* matrices which can be identified with $\mathbb{R}^{\frac{k(k+1)}{2}}$. In other words, we require that the columns of any $A \in S_{n,k}$ form an orthonormal system. As particular cases we have $S_{n,1} = S^{n-1}$, $S_{n,n} = O(n)$ the classical (real) *orthogonal groups*. As $M(n, k, \mathbb{R}) = (\mathbb{R}^n)^k$, we see immediately that $S_{n,k} \subset (S^{n-1})^k$, hence $S_{n,k}$ is compact. The above action of $\text{GL}(n, \mathbb{R})$ on $L_{n,k}$ restricts to a transitive action of $O(n)$ on $S_{n,k}$: for every $A \in S_{n,k}$, there exists $P \in O(n)$ such that $PA = I_{n,k}$. It follows that in order to prove that $S_{n,k}$ is an embedded smooth manifold in $(\mathbb{R}^n)^k$, it is enough to prove that there is a chart (W, ϕ) of $S_{n,k}$ at $J := I_{n,k}$. Hence it is enough to prove that $d_J f$ is surjective and conclude by applying again Theorem 1.4. Let us compute $d_J f$ by the very definition of the differential. Then

$$df_J(B) = \lim_{t \rightarrow 0} \frac{(J + tB)^t (J + tB) - I_k}{t} =$$

$$\lim_{t \rightarrow 0} (J^t B + B^t J + tB^t B) = J^t B + B^t J.$$

We have to prove that for every symmetric matrix $C \in S(k, \mathbb{R})$ there exists $B \in M(n, k, \mathbb{R})$ such that $J^t B + B^t J = C$. Set $B = \frac{1}{2}JC$. Then

$$J^t B + B^t J = \frac{1}{2}J^t JC + \frac{1}{2}C^t J^t J = \frac{1}{2}C + \frac{1}{2}C^t = C$$

because $C = C^t$. Summarizing, $S_{n,k}$ is a compact embedded smooth manifold in $L_{n,k} \subset M(n, k, \mathbb{R}) = (\mathbb{R}^n)^k$, of dimension

$$\dim S_{n,k} = nk - \frac{k(k+1)}{2}.$$

$S_{n,k}$ is called a *orthogonal Stiefel manifold*. In particular the orthogonal group $O(n)$ is a compact embedded smooth submanifold of $(S^{n-1})^n$ of dimension

$$\dim O(n) = n^2 - \frac{n(n+1)}{2}.$$

REMARK 3.1. The operation $(A, B) \rightarrow AB$, and $A \rightarrow A^{-1}$ that define the group structure of $\mathrm{GL}(n, \mathbb{R})$ are smooth (for A^{-1} recall the determinantal formula based on *Cramer's rule*). These restrict to smooth operations giving the group structure of the manifold $O(n)$. Hence $\mathrm{GL}(n, \mathbb{R})$ and $O(n)$ are basic examples of *Lie group*. $O(n)$ is a Lie subgroup of $\mathrm{GL}(n, \mathbb{R})$, in the sense that the first is a submanifold of the second and the smooth operations are compatible.

The *Gram-Schmidt orthonormalization algorithm* applied to the ordered columns of every $A \in L_{n,k}$ defines a smooth map

$$\mathfrak{r}_{n,k} : L_{n,k} \rightarrow S_{n,k}$$

which is onto and such that $\mathfrak{r}_{n,k}(A) = A$ for every $A \in S_{n,k}$. The map $\mathfrak{r}_{n,k}$ is the *canonical retraction* of $L_{n,k}$ onto $S_{n,k}$.

3.2. Fibrations of Stiefel manifolds by Stiefel manifolds

For every $0 \leq h < k \leq n$, $L_{n,k}$ is a submanifold (an open set) in the product $L_{n,h} \times L_{n,k-h}$ and denote by

$$l_{k,h} : L_{n,k} \rightarrow L_{n,h}$$

the restriction of the natural projection onto the first factor. This map is *equivariant* for the above actions of $\mathrm{GL}(n, \mathbb{R})$ on both Stiefel manifolds (i.e. $l_{k,h}(PA) = Pl_{k,h}(A)$), hence in order to study local properties such as the smoothness of the map, it is enough to study the restriction of $l_{k,h}$ on $l_{k,h}^{-1}(\Omega)$ where Ω is a neighbourhood of $I_{n,h}$. Clearly $l_{k,h}(I_{n,k}) = I_{n,h}$. The fibre $F_{k,h} := l_{k,h}^{-1}(I_{n,h})$ over $I_{n,h}$ is made by the 2×2 block matrices of the form

$$Y(S, D) := \begin{pmatrix} I_h & S \\ 0 & D \end{pmatrix}$$

where $(S, D) \in M(h, k-h, \mathbb{R}) \times L_{n-h, k-h}$. If $P \in \mathrm{GL}(n, \mathbb{R})$ is such that $PI_{n,h} = A$, then $P(l_{k,h}^{-1}(I_{n,h})) = l_{k,h}^{-1}(A)$, all fibres are diffeomorphic to each other. Let Ω be the open neighbourhood of $I_{n,h}$ made by matrices of the form

$$X = \begin{pmatrix} B \\ R \end{pmatrix}$$

where $B \in \mathrm{GL}(h, \mathbb{R})$. We define the smooth map $X \rightarrow P(X) \in \mathrm{GL}(n, \mathbb{R})$

$$P(X) = \begin{pmatrix} B & 0 \\ R & I_{n-h} \end{pmatrix}$$

such that $P(X)I_{n,h} = X$. Finally we have the following commutative diagram of smooth maps

$$\begin{array}{ccc} \Omega \times F_{k,h} & \xrightarrow{\Psi} & l_{k,h}^{-1}(\Omega) \\ \downarrow \pi_\Omega & & \downarrow l_{k,h} \\ \Omega & \xrightarrow{\mathrm{id}_\Omega} & \Omega \end{array}$$

such that the first row is the diffeomorphism defined by

$$(X, S, D) \rightarrow P(X)Y(S, D).$$

The constant section of the product on the left, $X \rightarrow (X, 0, I_{n-h, k-h})$ is transformed into the section of $l_{k,h}$ over Ω :

$$s(X) = \begin{pmatrix} B & 0 \\ R & I_{k-h} \end{pmatrix}$$

A similar construction can be performed for the orthogonal Stiefel manifolds. For every $0 \leq h < k \leq n$, $S_{n,k}$ is a submanifold in the product $S_{n,h} \times S_{n,k-h}$ and denote by

$$h_{k,h} : S_{n,k} \rightarrow S_{n,h}$$

the restriction of the natural projection onto the first factor. This map is *equivariant* for the above actions of $O(n)$ on both Stiefel manifolds. Clearly $h_{k,h}(I_{n,k}) = I_{n,h}$. The fibre $h_{k,h}^{-1}(I_{n,h})$ over $I_{n,h}$ is made by the 2×2 block matrices of the form

$$Y(D) := \begin{pmatrix} I_h & 0 \\ 0 & D \end{pmatrix}$$

where $D \in S_{n-h, k-h}$. If $P \in O(n)$ is such that $PI_{n,h} = A$, then $P(h_{k,h}^{-1}(I_{n,h})) = h_{k,h}^{-1}(A)$, all fibres are diffeomorphic to each other. Let Ω be the open neighbourhood of $I_{n,h}$ in $S_{n,h}$ made by matrices of the form

$$X = \begin{pmatrix} B \\ R \end{pmatrix}$$

where $B \in O(h)$. Recall the ‘‘Gram-Schmidt’’ retractions $\mathfrak{r}_{n,k}$ defined above. Then we define the smooth map $X \rightarrow P(X) \in O(n)$

$$P(X) = \mathfrak{r}_{n,n} \left(\begin{pmatrix} B & 0 \\ R & I_{n-h} \end{pmatrix} \right)$$

such that $P(X)I_{n,h} = X$. Finally we have the following commutative diagram of smooth maps

$$\begin{array}{ccc} \Omega \times S_{n-h, k-h} & \xrightarrow{\Psi} & h_{k,h}^{-1}(\Omega) \\ \downarrow \pi_\Omega & & \downarrow h_{k,h} \\ \Omega & \xrightarrow{\text{id}_\Omega} & \Omega \end{array}$$

such that the first row is the diffeomorphism defined by

$$(X, D) \rightarrow P(X)Y(D).$$

The constant section of the product on the left, $X \rightarrow (X, 0, I_{n-h, k-h})$ is transformed into the section of $h_{k,h}$ over Ω

$$s(X) = \mathfrak{r}_{n,k} \left(\begin{pmatrix} B & 0 \\ R & I_{k-h} \end{pmatrix} \right)$$

Summing up:

All these restriction of natural projections onto Stiefel manifolds are locally trivial(izable) fibrations with a transitive action of either the group $GL(n, \mathbb{R})$ or $O(n)$ respectively, which sends fibres into fibres. In the case of orthogonal Stiefel manifolds, the fibre is a Stiefel manifold itself.

• A case of particular interest is when $n = k$. In the linear case we have a fibration of the linear group $GL(n, \mathbb{R})$ over $L_{n,h}$ with fibre the *subgroup* of $GL(n, \mathbb{R})$ made by the matrices of the form

$$Y(S, D) := \begin{pmatrix} I_h & S \\ 0 & D \end{pmatrix}$$

where $(S, D) \in M(h, n-h, \mathbb{R}) \times GL(n-h, \mathbb{R})$.

In the orthogonal case we have a fibration of the orthogonal group $O(n)$ over $S_{n,h}$ with fiber the orthogonal group $O(n-h)$. Sometimes this is summarized by writing

$$S_{n,h} = O(n)/O(n-h).$$

- Another useful fibration is $h_{k,1} : S_{n,k} \rightarrow S^{n-1}$ with fibre $S_{n-1,k-1}$.
- Recall that $O(n)$ has two connected components and that the component containing I_n is the special orthogonal group $SO(n)$. If $h < n$, also the action of $SO(n)$ on $S_{n,h}$ is transitive, hence we can specialize all the discussion obtaining a fibration

$$sh_{n,h} : SO(n) \rightarrow S_{n,h}$$

with fibre $SO(n-h)$, so that

$$S_{n,h} = SO(n)/SO(n-h)$$

in particular this implies that

For $h < n$, the Stiefel manifold $S_{n,h}$ is connected.

3.3. Grassmann manifolds

For every (n, k) as above, we are going to define now the *Grassmann manifold* $\mathfrak{G}_{n,k}$.

Denote by $G_{n,k}$ the set of linear subspaces of \mathbb{R}^n of dimension k . Let $\mathfrak{G}_{n,k}$ be the closed subset of $S(n, \mathbb{R}) = \mathbb{R}^{\frac{n(n+1)}{2}}$ defined by the polynomial matrix equations

$$A^2 - A = 0, \text{ trace}(A) = k.$$

If $A \in S(n, \mathbb{R})$ verifies $A^2 - A = 0$ then its spectrum of eigenvalues is $\{0, 1\}$, and by the spectral theorem for real symmetric matrices, the respective eigenspaces provide an orthogonal direct sum decomposition of \mathbb{R}^n ; the last condition on the trace is equivalent to the fact that the eigenspace for the eigenvalue $\lambda = 1$ has dimension equal to k , and also to the fact that A has rank equal to k .

We fix a bijection $V \rightarrow A_V$ from $G_{n,k}$ onto $\mathfrak{G}_{n,k}$ as follows. For every $V \in G_{n,k}$ we have the orthogonal direct sum decomposition $\mathbb{R}^n = V \oplus V^\perp$, (V^\perp being the orthogonal space to V with respect to the standard euclidean scalar product) and the linear map $A_V \in \mathcal{L}(\mathbb{R}^n, \mathbb{R}^n) = M(n, \mathbb{R})$ such that $A_V(v + v') = v$. One readily verifies that $A_V \in \mathfrak{G}_{n,k}$. The inverse map $A \rightarrow V_A$ is defined by setting V_A equal to the eigenspace of A relative to the eigenvalue $\lambda = 1$.

Next we prove that $\mathfrak{G}_{n,k}$ is an embedded smooth manifold in $S(n, \mathbb{R})$, of dimension $k(n-k)$. Note that the action by smooth diffeomorphisms of $O(n)$ on $S(n, \mathbb{R})$ given by $(P, A) \rightarrow P^t A P$, restricts to an action on $\mathfrak{G}_{n,k}$: for every $A \in \mathfrak{G}_{n,k}$ $(P^t A P)^2 - P^t A P = P^t (A^2 - A) P = 0$; as $P^t = P^{-1}$, then $\text{trace}(P A P^{-1}) = k$ because the trace is invariant up to conjugation. This action corresponds via the above bijection $V \rightarrow A_V$ to the action of $O(n)$ on the set $G_{n,k}$ defined by $(P, V) \rightarrow P V$. These actions are transitive, hence for every $A \in \mathfrak{G}_{n,k}$ there exists $P \in O(n)$ such that $P^t A P = H$ where H is the 2×2 block diagonal matrix

$$H = \begin{pmatrix} I_k & 0 \\ 0 & 0 \end{pmatrix}$$

So it is enough to find a chart of $\mathfrak{G}_{n,k}$ at H . First note that the space of symmetric matrices of rank k (denote it by $S(n|k, \mathbb{R})$) is a submanifold of $S(n, \mathbb{R})$ of dimension $\frac{k(k+1)}{2} + k(n-k)$. A local parametrization of $S(n|k, \mathbb{R})$ at H is given by

$$(S(k, \mathbb{R}) \cap \text{GL}(k, \mathbb{R})) \times M(k, n-k, \mathbb{R}) \rightarrow \mathcal{W} \subset S(n|k, \mathbb{R}), (D, B) \rightarrow Z(D, B)$$

where $Z(D, B)$ is the 2×2 block symmetric matrix

$$Z(D, B) = \begin{pmatrix} D & B \\ B^t & B^t D^{-1} B \end{pmatrix}$$

To see that $Z(D, B)$ is of rank k , consider the non singular matrix

$$X(D, B) = \begin{pmatrix} I_k & 0 \\ -B^t D^{-1} & I_{n-k} \end{pmatrix}$$

then

$$X(D, B)Z(D, B) = \begin{pmatrix} D & B \\ 0 & 0 \end{pmatrix}$$

This last matrix has the same rank of $Z(D, B)$ and this is equal to $\text{rank}(D) = k$. The same argument shows that if one changes the second block along the diagonal of $Z(D, B)$ by any one different from $B^t D^{-1} B$, then the resulting matrix would have rank $> k$. Clearly $Z(I_k, 0) = H$. Hence $\mathcal{W} \cap \mathfrak{G}_{n,k}$ is given by restriction to \mathcal{W} of the matrix equation $A^2 - A = 0$. The matrix equation carried by the first $k \times k$ block along the diagonal reads:

$$BB^t + D^2 - D = 0$$

and by replacing $BB^t = D - D^2$ into the equations carried by the other blocks, a direct computation shows that they are automatically satisfied. We are reduced to study the map

$$h : (S(k, \mathbb{R}) \cap \text{GL}(k, \mathbb{R})) \times M(k, n-k, \mathbb{R}) \rightarrow S(k, \mathbb{R}), (D, B) \rightarrow BB^t + D^2 - D$$

which is a summersion at $(I_k, 0)$; hence, possibly shrinking \mathcal{W} , we conclude that $Z(h^{-1}(0)) = \mathcal{W} \cap \mathfrak{G}_{n,k}$ is an embedded smooth manifold of dimension $k(n-k)$.

An alternative way to get the same conclusion is to provide a local parametrization of $\mathfrak{G}_{n,k}$ at H . Let \tilde{U} be the subset of $G_{n,k}$ formed by the k -linear subspaces V of $\mathbb{R}^n = \mathbb{R}^k \times \mathbb{R}^{n-k}$ such that $V \cap \mathbb{R}^{n-k} = \{0\}$. Every $V \in \tilde{U}$ is the graph of a uniquely determined linear map $L_V : \mathbb{R}^k \rightarrow \mathbb{R}^{n-k}$. In fact the restriction to V of the projection onto \mathbb{R}^k is a linear isomorphism; hence the inverse isomorphism is of the form $x \rightarrow (x, L_V(x))$. Then \tilde{U} can be identified with $M(n-k, k, \mathbb{R})$. The restriction to $M(n-k, k, \mathbb{R})$ of the above map $V \rightarrow A_V$ can be explicitly computed as follows. For every $L \in M(n-k, k, \mathbb{R})$, let $V = V_L$ be the graph of L . Consider the ordered basis of \mathbb{R}^n

$$\mathcal{B}_L = \{(e_1, L(e_1)), \dots, (e_k, L(e_k)), e_{k+1}, \dots, e_n\}$$

such that the first k -vectors form a basis of V . Apply to \mathcal{B}_L the Gram-Schmidt orthogonalization algorithm which produces an orthonormal basis \mathcal{D}_L of \mathbb{R}^n , whose first k vectors are a orthonormal basis of V and the last $n-k$ of V^\perp . By organizing as usual \mathcal{D}_L in a $n \times n$ matrix, we get $P_L \in O(n)$. Finally $A_L = A_V = P_L^t H P_L$. The map $L \rightarrow A_L$ is clearly smooth; by a bit of direct computation we see that it is indeed an immersion. Finally, if Ω is a sufficiently small neighbourhood of H in $S(n, \mathbb{R})$, and $W = \Omega \cap \mathfrak{G}_{n,k}$, then for every $A \in W$, V_A belongs \tilde{U} ; the restriction to W of $A \rightarrow L_V$ is a chart of $\mathfrak{G}_{n,k}$ with values in an open neighbourhood U of $0 \in M(n-k, k)$. We have eventually proved that $\mathfrak{G}_{n,k}$ is an embedded smooth manifold of dimension $k(n-k)$ in $S(n, \mathbb{R})$.

3.4. Stiefel manifolds as fibre bundles over Grassmann manifolds

There are natural surjective maps

$$l_{n,k} : L_{n,k} \rightarrow \mathfrak{G}_{n,k}$$

$$s_{n,k} : S_{n,k} \rightarrow \mathfrak{G}_{n,k}$$

defined in both cases by $B \rightarrow A_{[B]}$ where $[B]$ denotes the linear k -subspace of \mathbb{R}^n generated by the columns of B .

Let us concentrate on the map $s_{n,k}$. Note that $[B] = [C]$ if and only if there exists $Q \in O(k)$ such that $C = BQ$, and that $A_{[B]} = H$ if and only if it is of the form

$$B = \begin{pmatrix} Q \\ 0 \end{pmatrix}, \quad Q \in O(k).$$

It follows that every fibre of $s_{n,k}$ is diffeomorphic to $O(k)$ and there is a transitive action (on the *right*) of $O(k)$ itself on every fibre.

The map $s_{n,k}$ is *equivariant* with respect to the actions of $O(n)$: $(P, B) \rightarrow PB$ on $S_{n,k}$, $(P, A) \rightarrow P^tAP$ on $\mathfrak{G}_{n,k}$, respectively. Recall that ‘equivariant’ means that for every (P, B) , $A_{[PB]} = P^tA_{[B]}P$. Then it is enough to analyse the behaviour of the restriction of the map to the inverse image $\tilde{\Omega} := s_{n,k}^{-1}(\Omega)$ (which is an open neighbourhood of J in $S_{n,h}$) of some open neighbourhood Ω of H in $\mathfrak{G}_{n,h}$. For every $B \in S_{n,k}$, if P is the top $k \times k$ submatrix of B , let us express this by writing $B = (P|D)$. Let $\tilde{\Omega}$ be the open neighbourhood of J in $S_{n,k}$ formed by the matrices $B = (P|D)$ such that P is non singular. If $B \in \tilde{\Omega}$ then $[B] \cap \mathbb{R}^{n-k} = \{0\}$, hence its image say Ω in $\mathfrak{G}_{n,k}$ is an open set. Moreover, if $[(P|D)] = [(R|S)]$, then there is $Q \in O(k)$ such that $(P|D) = (RQ|SQ)$. If P is non singular, then also R is necessarily non singular. This means that $\tilde{\Omega} = s_{n,k}^{-1}(\Omega)$ that is a *saturated* open set of $S_{n,k}$ with respect to the surjective map $s_{n,k}$. We can make explicit $s_{n,k}(B)$ on $\tilde{\Omega}$ by applying to every $[B]$ and its orthonormal basis given by B itself the construction already used above in order to construct a local parametrization of $\mathfrak{G}_{n,k}$ at H . This shows that $s_{n,k}$ is smooth. Moreover, define $\phi : \tilde{\Omega} \rightarrow M(k, n-k, \mathbb{R})$ by $\phi((P|D)) = DP^{-1}$. If $(P|D) = (RQ|SQ)$ as above, then $SQQ^{-1}R^{-1} = SR^{-1}$. Then there is an induced smooth map $\Omega \rightarrow M(k, n-k, \mathbb{R})$ whose inverse map is

$$\psi : M(k, n-k) \rightarrow \Omega, \quad \psi(Z) = A_{[\tau_{n,k}(I_k|Z)]}$$

providing once again a local parametrization of $\mathfrak{G}_{n,k}$ at H . We can summarize this discussion by saying that there is a locally trivializing commutative diagram at H

$$\begin{array}{ccc} \Omega \times O(k) & \xrightarrow{\Psi} & \tilde{\Omega} \\ \downarrow \pi_\Omega & & \downarrow s_{n,k} \\ \Omega & \xrightarrow{\text{id}_\Omega} & \Omega \end{array}$$

where $\Psi(A, Q) = \psi(Z)Q$, $A = \psi(Z)$. Its orbit by the action of $O(n)$ provides a fibred atlas for the summersion $s_{n,k}$. Summing up we have proved:

PROPOSITION 3.2. *The map $s_{n,k} : S_{n,k} \rightarrow \mathfrak{G}_{n,k}$ is a fiber bundle with fibre $O(k)$. Every change of trivialization*

$$\Phi' \circ \Psi(\Omega \cap \Omega') \times O(k) \rightarrow (\Omega \cap \Omega') \times O(k)$$

is of the form

$$(p, P) \rightarrow (p, PQ(p))$$

where $p \rightarrow Q(p)$ defines a smooth map $\Omega \cap \Omega' \rightarrow O(k)$.

We have also the following topological corollaries

COROLLARY 3.3. *Every $\mathfrak{G}_{n,k}$ is a compact and connected embedded smooth manifold. As a topological space it has the quotient space topology $S_{n,k}/s_{n,k}$.*

- *Real projective spaces.* A particular case of the above discussion is when $k = 1$. In such a case $\mathfrak{G}_{n,1}$ is also denoted by $\mathbf{P}^{n-1}(\mathbb{R})$ and called the (real) $(n-1)$ -projective space. $S_{n,1} = S^{n-1}$, and the map $s = s_{n,1} : S^{n-1} \rightarrow \mathbf{P}^{n-1}(\mathbb{R})$ is a *smooth covering map of degree 2*.

- *Complex Stiefel and Grassmann manifolds.* As a smooth manifold $\mathbb{C}^n = \mathbb{R}^{2n}$, hence $M(n, \mathbb{C})$ is a submanifold of $M(2n, \mathbb{R})$ etc. All along the above discussion let us replace:

- \mathbb{R}^n with \mathbb{C}^n . The real linear subspaces of \mathbb{R}^n with the *complex* linear subspaces of \mathbb{C}^n .
- The standard positive definite scalar product on \mathbb{R}^n with the standard positive definite *Hermitian product* on \mathbb{C}^n , $\langle v, w \rangle = v^t \bar{w}$.
- The (real) orthogonal groups $O(n)$ with the *unitary groups*

$$U(n) := \{A \in \text{GL}(n, \mathbb{C}); A^{-1} = A^* := \bar{A}^t\} .$$

- The spaces of real symmetric matrices $S(n, \mathbb{R})$ with the spaces of *Hermitian matrices*

$$H(n, \mathbb{C}) = \{A \in M(n, \mathbb{C}); A = A^*\} .$$

- The spectral theorem for real symmetric matrices with the *spectral theorem for complex hermitian matrices*.

Then by repeating verbatim the above constructions, for every (n, k) as above, we realize the (unitary) *complex Stiefel manifold* $S_{n,k}(\mathbb{C})$ as a compact embedded smooth manifold in $M(n, k, \mathbb{C})$, the complex Grassmannian manifold $\mathfrak{G}_{n,k}(\mathbb{C})$ as a compact embedded smooth manifold in $H(n, \mathbb{C})$ (defined by the usual equations $A^2 - A = 0$, $\text{trace}(A) = k$), the complex projective spaces $\mathbf{P}^{n-1}(\mathbb{C}) = \mathfrak{G}_{n,1}(\mathbb{C})$, and so on. Although we are dealing with spaces based on the *complex numbers*, we stress that in this way we have actually realized them as *real* embedded smooth manifolds.

We understand that also all next considerations about Stiefel and Grassmann manifolds would have a counterpart for the complex version.

3.5. A cellular decomposition of the Grassmann manifolds

We describe a natural partition of $\mathfrak{G}_{n,k}$ by a finite number of subsets each one diffeomorphic to some \mathbb{R}^h , $0 \leq h \leq \dim \mathfrak{G}_{n,k}$, (i.e. an *open h-cell*) and such that its closure in $\mathfrak{G}_{n,k}$ is union of cells of lower dimension. Let $L \in \mathfrak{G}_{n,k}$, that is L is a k -dimensional linear subspace of \mathbb{R}^n (here we confuse $G_{n,k}$ and $\mathfrak{G}_{n,k}$). For every $i = 0, \dots, n$, denote by

$$p_i : \mathbb{R}^n \rightarrow \mathbb{R}^{n-i}$$

the projection onto the first $n - i$ coordinates, $p_i((x_1, \dots, x_n)^t) = (x_1, \dots, x_{n-i})^t$. The dimensions of $p_i(L) \subset \mathbb{R}^{n-i}$ decrease from k to 0 in exactly k steps; that is there are integers

$$1 \leq \sigma_1 < \sigma_2 < \dots < \sigma_k \leq n$$

such that for j that decreases from k to 1,

$$\dim p_{\sigma_{j+1}}(L) - \dim p_{\sigma_j}(L) = 1 .$$

Then

$$\sigma(L) := (\sigma_1, \dots, \sigma_k)$$

is called the *Schubert symbol* of L . There is a concrete elementary way to determine $\sigma(L)$:

- Fix any rank k , $n \times k$ matrix $A \in L_{n,k}$ which projects to $L \in \mathfrak{G}_{n,k}$.
- Apply to A the Gauss algorithm via elementary operations on the columns and get a matrix

$$\hat{A} \in L_{n,k}$$

in *column echelon form* which also projects to L . So for every $j = 1, \dots, k$, the (σ_j, j) entry of \hat{A} is equal to 1 and is a so called ‘pivot’ of \hat{A} ; the (transposed of the) σ_j th row of \hat{A} is the σ_j th vector of the standard basis of \mathbb{R}^k ; beyond the pivots, for every $1 \leq j \leq k$, an (s, j) entry of \hat{A} is possibly non zero only if $\sigma_j < s \leq n$ and s is not the row index of any pivot row. The computation of $\sigma(L)$ by means of \hat{A} is immediate from the very definition. This means in particular that the initial

choice of the matrix A is immaterial to this computation of $\sigma(L)$; $\sigma(\hat{A}) := \sigma(L)$ is the symbol of the matrix \hat{A} and two matrices in column echelon form have the same index if and only if they share the pivot positions.

We claim furthermore that the whole matrix \hat{A} does not depend on the choice of A as it is completely determined by L . For, given $\sigma = \sigma(L)$, denote by p_σ the projection of \mathbb{R}^n onto the k coordinates $(x_{\sigma_1}, \dots, x_{\sigma_k})$; then the restriction of p_σ to L is a linear isomorphism and the columns of \hat{A} are characterized as the vectors of L which are mapped in the order by p_σ to the vectors $e_{\sigma_1}, \dots, e_{\sigma_k}$ of the standard basis of \mathbb{R}^k .

Summarizing, there are $\binom{n}{k}$ Schubert symbols. For every such a symbol σ , the subset C_σ of $\mathfrak{G}_{n,k}$ formed by the k -subspaces of \mathbb{R}^n which share the symbol σ is in bijection with the subset \hat{C}_σ of $L_{n,k}$ formed by the matrices in columns echelon forms which also share the symbol σ . \hat{C}_σ has a natural base point, that is the matrix J_σ whose entries different from the pivots are zero; then

$$\hat{C}_\sigma = J_\sigma + \mathbf{V}_\sigma$$

and it is easy to check that \mathbf{V}_σ is a linear subspace of $M(n, k, \mathbb{R})$ formed by the matrices with a given pattern of zero entries determined by the symbol σ . The other entries contain free parameters. By counting the free parameters column by column, we readily verify that

$$d_\sigma := \dim \mathbf{V}_\sigma = \sum_{j=1}^k (n - \sigma_j - (k - j)) .$$

It follows that $C_\sigma \subset \mathfrak{G}_{n,k}$ admits a smooth parametrization

$$\psi_\sigma : \mathbb{R}^{d_\sigma} \rightarrow C_\sigma .$$

By varying the symbols we have obtained a partition of $\mathfrak{G}_{n,k}$ by open cells. We claim that:

The closure of every C_σ in $\mathfrak{G}_{n,k}$ is formed by the $C_{\sigma'}$'s such that for every j , $\sigma'_j \geq \sigma_j$.

This claim is not obvious. We omit the proof, however next item 4) should help the reader to reconstruct such a proof.

Remarks and examples.

1) There is one top dimensional (i.e. of dimension $k(n - k)$) cell of $\mathfrak{G}_{n,k}$ corresponding to the symbol $(1, 2, 3, \dots, k)$. This covers a chart around the image of $I_{n,k}$ in $\mathfrak{G}_{n,k}$. In general every cell C_σ has a natural base point, that is the image in $\mathfrak{G}_{n,k}$ of the the matrix $J_\sigma \in \hat{C}_\sigma$. There is one 0-cell corresponding to the symbol $(n - k + 1, n - k, \dots, n)$.

2) In the case of projective spaces $\mathbf{P}^n(\mathbb{R}) = \mathfrak{G}_{n+1,1}$, there are $n + 1$ cells, one cell for every dimension $n, \dots, 0$ corresponding to the symbols $(1), (2), \dots, (n + 1)$. The closure of every cell of dimension d say is a copy of $\mathbf{P}^d(\mathbb{R})$ linearly embedded into $\mathbf{P}^n(\mathbb{R})$.

3) For example $\mathfrak{G}_{4,2}$ has six cells corresponding to the Schubert symbols $(1, 2)$, $(1, 3)$, $(1, 4)$, $(2, 3)$, $(2, 4)$, $(3, 4)$, and these cells have dimensions 4, 3, 2, 2, 1, 0 respectively.

4) The cells of $\mathfrak{G}_{n,k}$ can be described also in terms of the orthogonal Stiefel manifold $S_{n,k}$. A matrix $\tilde{A} \in S_{n,k}$ is in *orthogonal* column echelon form of symbol σ if its standard column echelon form \hat{A} is of symbols σ and \tilde{A} may differ from \hat{A} only by: 1) the pivot entries of \tilde{A} are non zero not necessarily equal to 1; 2) the entries of a pivot row of \tilde{A} on the left of the pivot are not necessarily equal to 0; 3) the last non zero entry of every column is positive. One can verify that for every $L \in \mathfrak{G}_{n,k}$ there is only one $\tilde{A} \in S_{n,k}$ which projects to L ; in fact if \hat{A} is the unique

matrix in standard column echelon form which projects to L , then we can obtain \tilde{A} by applying the Gram-Schmidt algorithm to the columns of \tilde{A} considered in the backward order (normalized to achieve also the condition 3) above). The subset \tilde{C}_σ of $S_{n,k}$ formed by the matrix in echelon form of symbol σ is diffeomorphic to $\hat{C}_\sigma \subset L_{n,k}$ and maps diffeomorphically onto $C_\sigma \subset \mathfrak{G}_{n,k}$. One can prove that the closure of \tilde{C}_σ in $S_{n,k}$ is diffeomorphic to a *closed* disk of dimension d_σ which maps onto the closure of C_σ in $\mathfrak{G}_{n,k}$.

5) Referring to Section 4.5, the cell decompositions respect the inclusions

$$j_n : \mathfrak{G}_{n,k} \rightarrow \mathfrak{G}_{n+1,k}$$

in the sense that the cells of $\mathfrak{G}_{n,k}$ are also cells of $\mathfrak{G}_{n+1,k}$; hence we have also a cell decomposition of the limit infinite Grassmannian $\mathfrak{G}_{\infty,k}$.

3.6. Stiefel and Grassmannian manifolds as regular real algebraic sets

For the notions and basic results of (real) algebraic geometry mentioned in this section we can refer for example to [BCR] or to [BR].

By definition a *real algebraic set* $Z \subset \mathbb{R}^m$, for some $m \in \mathbb{N}$, is of the form $Z = F^{-1}(0)$ for some *polynomial* map $F : \mathbb{R}^m \rightarrow \mathbb{R}^h$. Hence the Stiefel and Grassmannian manifolds (even in the complex version) are also examples of real algebraic sets. We are going to outline a way to recover that they are embedded smooth manifolds by the means of algebraic geometry, obtaining indeed a stronger result.

For every algebraic set Z as above,

$$I(Z) := \{p(X) \in \mathbb{R}[X_1, \dots, X_m]; p(x) = 0 \text{ for every } x \in Z\}$$

is called the (defining) *ideal* of Z . By a theorem of Hilbert, $I(Z)$ is *finitely generated*, that is there exist some polynomials $p_1(X), \dots, p_k(X) \in I(Z)$ such that $I(Z)$ coincides with the set of linear combinations of the $p_j(X)$'s with polynomial coefficients in $\mathbb{R}[X_1, \dots, X_m]$. Consider the polynomial map

$$P : \mathbb{R}^m \rightarrow \mathbb{R}^k, P(x) = (p_1(x), \dots, p_k(x)).$$

For every $p \in Z$, set

$$r(p) = \text{rank } d_p P.$$

It is not too hard to show that $r(p)$ *does not depend on the choice of the generators* p_1, \dots, p_k . So it is well defined

$$r(Z) = \max\{r(p); p \in Z\}.$$

Assume for simplicity that Z is *irreducible* that is it cannot be expressed as $Z = Z_1 \cup Z_2$ where Z_1 and Z_2 are algebraic sets both different from Z (one can prove that the connected Stiefel and Grassmannian algebraic sets are irreducible - that is all with the exception of the orthogonal groups $O(n)$). Then $p \in Z$ is a *regular point* if $r(p) = r(Z)$. Note that by the definition, the set $R(Z)$ of regular points of Z is *non empty*. A *Zariski open set* in \mathbb{R}^m is of the form $\mathbb{R}^m \setminus Y$ where Y is an algebraic set in \mathbb{R}^m . The following is a non trivial result.

THEOREM 3.4. *Let $Z \subset \mathbb{R}^m$ be an irreducible algebraic set of rank $r = r(Z)$. Then for every $p \in R(Z)$ there exist a Zariski open set U of \mathbb{R}^m and a polynomial map $F = (F_1, \dots, F_r) : \mathbb{R}^m \rightarrow \mathbb{R}^r$ such that:*

- (1) $p \in U$.
- (2) $F_j \in I(Z)$, $j = 1, \dots, r$.
- (3) $Z \cap U = U \cap F^{-1}(0)$.
- (4) For every $x \in U \cap Z$,

$$\text{rank } d_x F = r.$$

In particular $R(Z)$ is an embedded smooth manifold in \mathbb{R}^m of dimension $m - r$.

Assuming this fundamental theorem, we can prove

COROLLARY 3.5. *Let $Z \subset \mathbb{R}^m$ be one of our favourite (Stiefel or Grassmannian) algebraic sets. Then $Z = R(Z)$. In particular Z is an embedded smooth manifold of dimension $m - r(Z)$.*

Proof: We know that $R(Z) \neq \emptyset$. Let $p \in R(Z)$. By using the suitable transitive action on Z of orthogonal (unitary) groups, we realize that for every $q \in Z$ there is a particularly simple linear diffeomorphism $\phi : \mathbb{R}^m \rightarrow \mathbb{R}^m$ such that $\phi(Z) = Z$ and $\phi(p) = q$. Although this is a particular case of a general result on the invariance of $R(Z)$ up to “algebraic isomorphism”, these diffeomorphisms are so simple that one can check directly that since p is regular then also q is regular. Then $Z = R(Z)$. \square

Note that the linear Stiefel manifolds are in fact Zariski open sets of the pertinent matrix space.

REMARK 3.6. (1) We stress that the notion of regular point is rather a delicate one. For example it can happen that for some irreducible algebraic set $X \subset \mathbb{R}^m$ which is an embedded smooth manifold, nevertheless $R(X) \neq X$.

Tautological bundles and pull-back

The basic notions about fibred bundles have been already introduced in Section 2.6, and we will use them. The tensorial vector bundles and their relatives, defined in Chapter 2 belong to a wide category of “embedded fibred bundles” constructed via the *pull-back* of *tautological bundles* over Grassmann manifolds. We are going to state these matters.

4.1. Tautological bundles

We are going to construct so called *tautological fibre bundles* over the grassmannian $\mathfrak{G}_{n,k}$.

- (*The tautological vector bundle*) Define

$$\mathcal{V}(\mathfrak{G}_{n,k}) = \{(A, v) \in \mathfrak{G}_{n,k} \times \mathbb{R}^n; v \in V_A\}$$

i.e. v belongs to the k -linear subspace V of \mathbb{R}^n such that $A = A_V$, via the usual bijection $G_{n,k} \cong \mathfrak{G}_{n,k}$. The restriction of the projection onto the first factor defines the smooth surjective map

$$\tau_{n,k} : \mathcal{V}(\mathfrak{G}_{n,k}) \rightarrow \mathfrak{G}_{n,k} .$$

It is clear that for every $A \in \mathfrak{G}_{n,k}$, the inverse image $\tau_{n,k}^{-1}(A) = V_A$. We have

PROPOSITION 4.1. $\tau_{n,k} : \mathcal{V}(\mathfrak{G}_{n,k}) \rightarrow \mathfrak{G}_{n,k}$ is an embedded smooth vector bundle with fibre \mathbb{R}^k . It is called the tautological vector bundle over $\mathfrak{G}_{n,k}$.

- (*The tautological linear frame bundle*) Define

$$\mathcal{L}(\mathfrak{G}_{n,k}) = \{(A, X) \in \mathfrak{G}_{n,k} \times L_{n,k}; l_{n,k}(X) = A\}$$

i.e. X spans the k -linear subspace V of \mathbb{R}^n such that $A = A_V$. The restriction of the projection onto the first factor defines the smooth surjective map

$$l\tau_{n,k} : \mathcal{L}(\mathfrak{G}_{n,k}) \rightarrow \mathfrak{G}_{n,k} .$$

It is clear that for every $A \in \mathfrak{G}_{n,k}$, the inverse image $l\tau_{n,k}^{-1}(A)$ consists of all *linear frames* of V_A . We have

PROPOSITION 4.2. $l\tau_{n,k} : \mathcal{L}(\mathfrak{G}_{n,k}) \rightarrow \mathfrak{G}_{n,k}$ is an embedded smooth fibre bundle with fibre $GL(k, \mathbb{R})$. It is called the tautological linear frame bundle over $\mathfrak{G}_{n,k}$.

- (*The tautological orthogonal frame bundle*) Define

$$\mathcal{S}(\mathfrak{G}_{n,k}) = \{(A, X) \in \mathfrak{G}_{n,k} \times S_{n,k}; s_{n,k}(X) = A\}$$

i.e. X spans the k -linear subspace V of \mathbb{R}^n such that $A = A_V$. The restriction of the projection onto the first factor defines the smooth surjective map

$$s\tau_{n,k} : \mathcal{S}(\mathfrak{G}_{n,k}) \rightarrow \mathfrak{G}_{n,k} .$$

It is clear that for every $A \in \mathfrak{G}_{n,k}$, the inverse image $s\tau_{n,k}^{-1}(A)$ consists of all *orthonormal frames* of V_A . We have

PROPOSITION 4.3. $s\tau_{n,k} : \mathcal{S}(\mathfrak{G}_{n,k}) \rightarrow \mathfrak{G}_{n,k}$ is an embedded smooth fibre bundle with fibre $O(k)$. It is called the tautological orthogonal frame bundle over $\mathfrak{G}_{n,k}$.

Proofs: Let us prove Proposition 4.1. Recall that $\mathfrak{G}_{n,k}$ is endowed with an atlas $\{(\Omega_V, \phi_V)\}_{V \in G_{n,k}}$ where

$$\Omega_V = \{A \in \mathfrak{G}_{n,k}; V_A \cap V^\perp = \{0\}\}$$

equivalently, V_A is the graph of a uniquely determined linear map $L_A : V \rightarrow V^\perp$. Set as usual $\tilde{\Omega}_V = \tau_{n,k}^{-1}(\Omega_V)$. Then a vector bundle atlas of $\tau_{n,k}$ is given by the locally trivializing commutative diagrams (V varying in $G_{n,k}$, $\mathcal{B} = \{v_1, \dots, v_k\}$ varying in the linear frames of V)

$$\begin{array}{ccc} \Omega_V \times \mathbb{R}^k & \xrightarrow{\Psi_{\mathcal{B}}} & \tilde{\Omega}_V \\ \downarrow \pi_{\Omega_V} & & \downarrow \tau_{n,k} \\ \Omega_V & \xrightarrow{\text{id}_{\Omega_V}} & \Omega_V \end{array}$$

where

$$\Psi_{\mathcal{B}}(A, x) = \left(A, \sum_{i=1}^k x_i v_i + \sum_{i=1}^k x_i L_A(v_i) \right).$$

It is immediate that for every couple (V, \mathcal{B}) , (V', \mathcal{B}') there is a smooth map

$$\lambda_{\mathcal{B}, \mathcal{B}'} : \Omega_V \cap \Omega_{V'} \rightarrow \text{GL}(k, \mathbb{R})$$

such that the corresponding change of local trivialization is of the form

$$\begin{aligned} (\Omega_V \cap \Omega_{V'}) \times \mathbb{R}^k &\rightarrow (\Omega_V \cap \Omega_{V'}) \times \mathbb{R}^k \\ (A, v) &\rightarrow (A, \lambda_{\mathcal{B}, \mathcal{B}'}(A)v). \end{aligned}$$

Remark. *By restricting to orthogonal frames \mathcal{B} of the V 's, we get a sub-fibred atlas such that the change of local trivializations are governed by smooth maps*

$$\lambda_{\mathcal{B}, \mathcal{B}'} : \Omega_V \cap \Omega_{V'} \rightarrow O(k).$$

The proof of the other two propositions is similar and left to the reader. Note that the change of local trivializations for the frame bundles are governed by *the same* smooth maps $\lambda_{\mathcal{B}, \mathcal{B}'}$ as above, with values in $\text{GL}(k, \mathbb{R})$ for $l\tau_{n,k}$, or in $O(k)$ for $s\tau_{n,k}$ respectively; the groups $\text{GL}(k, \mathbb{R})$ or $O(k)$ act on themselves by left multiplication. □

4.2. Pull-back

We introduce a fundamental construction on embedded smooth fibred bundles. We state it in wide generality; later we apply it to the tautological bundles of Section 4.1.

Let us give an embedded smooth fibre bundle

$$\xi := f : E \rightarrow X$$

with fibres E_x diffeomorphic to the manifold F (recall section 2.6).

Let $g \in \mathcal{E}(M, X)$. Then set

$$\begin{aligned} g^*E &= \{(p, y) \in M \times E; g(p) = f(y)\} \\ g^* : g^*E &\rightarrow E, \quad g^*(p, y) = y \\ g^*f : g^*E &\rightarrow M, \quad g^*f(p, y) = p. \end{aligned}$$

Obviously we have the commutative diagram of smooth maps, denoted by $[g, g^*]$

$$\begin{array}{ccc} g^*E & \xrightarrow{g^*} & E \\ \downarrow g^*f & & \downarrow f \\ M & \xrightarrow{g} & X \end{array}$$

Moreover, for every $p \in M$, $x = g(p)$, then $g^*E_p := (g^*f)^{-1}(p)$ is equal to the fibre E_x . Hence, also every g^*E_p is diffeomorphic to F . In fact we have

PROPOSITION 4.4. (1) For every fibre bundle $\xi := f : E \rightarrow X$ with fibre F , for every $g \in \mathcal{E}(M, X)$,

$$g^*\xi := g^*f : g^*E \rightarrow M$$

is an embedded smooth fibre bundle with fibre F . It is called the pull-back of ξ via g . Moreover, $[g, g^*]$ is a fibred map between fibred bundles.

(2) For every $h \in \mathcal{E}(N, M)$, every $g \in \mathcal{E}(M, X)$, then

$$(g \circ h)^*\xi = h^*(g^*\xi) .$$

(3)

$$(g \circ h)^* = g^* \circ h^* .$$

Proof : The second and third points follow from the very definitions. As for the first; consider a fibre bundle atlas of ξ . This is formed as usual by locally trivializing diagrams

$$\begin{array}{ccc} \Omega \times F & \xrightarrow{\Psi} & \tilde{\Omega} \\ \downarrow \pi_\Omega & & \downarrow f \\ \Omega & \xrightarrow{\text{id}_\Omega} & \Omega \end{array}$$

and any change of local trivializations is of the form

$$(\Omega \cap \Omega') \times F \rightarrow (\Omega \cap \Omega') \times F$$

$$(x, y) \rightarrow (x, \rho(x)(y))$$

$$x \rightarrow \rho(x) \in \text{Aut}(F) .$$

The Ω 's form an open covering of X . Fix an open covering $\{W\}$ of M such that $g(W)$ is contained in some Ω . Then for every W we have the locally trivializing commutative diagram

$$\begin{array}{ccc} W \times F & \xrightarrow{\Psi \circ (g, \text{id}_F)} & \tilde{W} \\ \downarrow \pi_W & & \downarrow g^*f \\ W & \xrightarrow{\text{id}_W} & W \end{array}$$

The change of local trivialization is of the form

$$(W \cap W') \times F \rightarrow (W \cap W') \times F$$

$$(w, y) \rightarrow (w, \rho(g(w))(y))$$

$$w \rightarrow \rho(g(w)) \in \text{Aut}(F) .$$

□

REMARK 4.5. If F has an additional structure preserved by a subgroup $G \subset \text{Aut}(F)$, and $x \rightarrow \rho(x)$ as above is a smooth map with values in G (i.e. ξ is a “ G -bundle”) then also the pull-back $g^*\xi$ has the same property. For example if ξ is a vector bundle (with fibre \mathbb{R}^k) then also $g^*\xi$ is so.

4.3. Categories of vector bundles

Let M be an embedded smooth manifold (possibly with boundary). Let

$$f : M \rightarrow \mathfrak{G}_{n,k}$$

be a smooth map. Then we can consider the pull-back vector bundle $f^*\tau_{n,k}$, that is

$$\begin{array}{ccc} f^*\mathcal{V}(\mathfrak{G}_{n,k}) & \xrightarrow{f^*} & \mathcal{V}(\mathfrak{G}_{n,k}) \\ \downarrow f^*\tau_{n,k} & & \downarrow \tau_{n,k} \\ M & \xrightarrow{f} & \mathfrak{G}_{n,k} \end{array} .$$

By the strict definition, the total space of $\text{id}_{\mathfrak{G}_{n,k}}^* \tau_{n,k}$ is a submanifold of $\mathfrak{G}_{n,k} \times (\mathfrak{G}_{n,k} \times \mathbb{R}^n)$; however, the projection onto the product of the first and third factors gives a canonical fibred diffeomorphism onto the total space of $\tau_{n,k}$. Modulo this *normalized embedding*, we can stipulate that

$$\text{id}_{\mathfrak{G}_{n,k}}^* \tau_{n,k} = \tau_{n,k} .$$

Similarly, for every $f : M \rightarrow \mathfrak{G}_{n,k}$ as above, the total space of $f^*\tau_{n,k}$ has a canonical embedding into $M \times \mathbb{R}^n$; modulo this normalization we can state that

$$\text{id}_M^*(f^*\tau_{n,k}) = f^*\tau_{n,k} .$$

We stipulate that such a normalization is performed by default. Note also that the composition of f^* with the natural projection of $\mathcal{V}(\mathfrak{G}_{n,k})$ to \mathbb{R}^n gives a map which is linear and injective at every fibre of $f^*(\mathcal{V}(\mathfrak{G}_{n,k}))$, from which we can reconstruct tautologically the map f .

Denote $\mathcal{N} = \{(n, k) \in \mathbb{N} \times \mathbb{N}; 0 \leq k \leq n\}$. For every $(n, k) \in \mathcal{N}$ set

$$\mathcal{V}_{n,k}(M) := \{f^*\tau_{n,k}; f \in \mathcal{E}(M, \mathfrak{G}_{n,k})\} ;$$

and

$$\mathcal{V}(M) = \cup_{(n,k) \in \mathcal{N}} \mathcal{V}_{n,k}(M) .$$

Then we see immediatly that

$$M \Rightarrow \mathcal{V}(M)$$

$$g : N \rightarrow M \Rightarrow g^\bullet : \mathcal{V}(M) \rightarrow \mathcal{V}(N), g^\bullet(f^*\tau_{n,k}) = (f \circ g)^*\tau_{n,k}$$

so that

$$(g \circ h)^\bullet = h^\bullet \circ g^\bullet$$

define a contravariant functor from the category of embedded smooth manifolds (with boundary) to this category of embedded smooth vector bundles. Moreover, for every f and every g as above there is the natural vector bundle map

$$[g, g^*] : g^\bullet(f^*\tau_{n,k}) \rightarrow f^*\tau_{n,k} .$$

If $g : N \rightarrow M$ is a diffeomorphism, then $g^\bullet : \mathcal{V}(M) \rightarrow \mathcal{V}(N)$ is a bijection (with inverse $(g^{-1})^\bullet$), and for every f , $[g, g^*]$ is a vector bundle isomorphism between $g^\bullet(f^*\tau_{n,k})$ and $f^*\tau_{n,k}$.

The tangent bundle of a manifold $M \subset \mathbb{R}^n$ as well all its tensorial relatives belong to $\mathcal{V}(M)$. For example $\pi_M : T(M) \rightarrow M$ is the pull-back of the (tautological) map

$$t_M : M \rightarrow \mathfrak{G}_{n,m}, t_M(p) = T_p M .$$

More generally we have

LEMMA 4.6. *If $\xi := f : E \rightarrow M$ is a smooth vector bundle with fibre \mathbb{R}^k such that the total space E is a submanifold of some \mathbb{R}^n , and every fibre E_x is a linear k -subspace of \mathbb{R}^n , then the bundle ξ belongs to $\mathcal{V}(M)$.*

Proof : In fact ξ is the pull-back of the (tautological) map

$$e_M : M \rightarrow \mathfrak{G}_{n,k}, \quad e_M(x) = E_x .$$

□

4.3.1. Bundle equivalences. We are going to refine the above constructions by introducing suitable quotient sets of $\mathcal{V}(M)$.

For every $f : M \rightarrow \mathfrak{G}_{n,k}$, and every inclusion $j_n : \mathfrak{G}_{n,k} \rightarrow \mathfrak{G}_{n+1,k}$ (see Section 4.5), the total space of $(j_n \circ f)^* \tau_{n+1,k}$ is embedded in $M \times \mathbb{R}^n$ and coincides with the total space of $f^* \tau_{n,k}$. This gives us a *canonical identification* between these formally different points of $\mathcal{V}(M)$. A first mild quotient of $\mathcal{V}(M)$ is obtained by means of such canonical identifications. Let us keep for it the name $\mathcal{V}(M)$. For every equivalence class, there is one representative $f^* \tau_{n,k}$ with *minimum* n .

More substantially we can restrict to $\mathcal{V}(M)$ the *full equivalence* between vector bundles defined in Section 2.6, generated by arbitrary vector bundle isomorphisms of the form $[g, \tilde{g}]$. Denote by $\mathbf{V}(M)$ the quotient set.

EXAMPLE 4.7. For example, if $g \in \text{Aut}(M)$, then for every $f : M \rightarrow \mathfrak{G}_{n,k}$, the corresponding $[g, g^*]$ realizes a full equivalence between $f^* \tau_{n,k}$ and $g^*(f^* \tau_{n,k})$. By the way this establishes an action of $\text{Aut}(M)$ on $\mathcal{V}(M)$, so that $\mathbf{V}(M)$ is a quotient set of $\mathcal{V}(M)/\text{Aut}(M)$.

We can restrict to $\mathcal{V}(M)$ the *strict equivalence* between vector bundles defined in Section 2.6, generated by isomorphisms of the form $[\text{id}_M, \tilde{g}]$. Denote by $\mathbf{V}_0(M)$ the quotient set. Clearly $\mathbf{V}(M)$ is a quotient of $\mathbf{V}_0(M)$.

EXAMPLE 4.8. (i) If $f, g : M \rightarrow \mathfrak{G}_{n,k}$ are two different constant maps, then $f^* \tau_{n,k}$ and $g^* \tau_{n,k}$ are different points of $\mathcal{V}(M)$ which obviously are strictly equivalent.

(ii) Let $g : M \rightarrow N$ be a diffeomorphism; then $[g^{-1}, Tg^{-1}] \circ [g, g^*]$ is a strict equivalence between $T(M)$ and $g^*T(N)$.

(iii) By generalizing the above item, let $[g, \tilde{g}]$ realize a full equivalence between bundles in $\mathcal{V}(M)$; then also $[g, g^*]$ as in the above example realizes such an equivalence. Moreover, $[g^{-1}, \tilde{g}^{-1}] \circ [g, g^*]$ realizes instead a strict equivalence.

• *By associating to every $f^* \tau_{n,k}$ its class in the preferred quotient set of $\mathcal{V}(M)$, we get variants of the basic pull-back functor defined above.*

We will concentrate on $\mathbf{V}_0(M)$. In particular we pose the following natural question: set

$$\mathcal{E}(M, \mathfrak{G}) := \cup_{(n,k) \in \mathcal{N}} \mathcal{E}(M, \mathfrak{G}_{n,k}) .$$

QUESTION 4.9. Consider the obvious surjective map

$$(\cdot)^* : \mathcal{E}(M, \mathfrak{G}) \rightarrow \mathbf{V}_0(M), \quad f \rightarrow [f^* \tau_{n,k}]$$

so that tautologically

$$\mathbf{V}_0(M) = \mathcal{E}(M, \mathfrak{G}) / (\cdot)^* .$$

This relation on $\mathcal{E}(M, \mathfrak{G})$ is only implicitly defined. The question is to *make it explicit*. An answer will be discussed later when M is compact.

4.4. The frame bundles

We can repeat the above scheme by using instead the tautological frame bundles. It is enough to replace $\mathcal{V}(M)$ either with

$$\begin{aligned} \mathcal{L}(M) &= \cup_{(n,k) \in \mathcal{N}} \mathcal{L}_{n,k}(M) \\ \mathcal{L}_{n,k}(M) &:= \{f^* l \tau_{n,k}; f \in \mathcal{E}(M, \mathfrak{G}_{n,k})\} . \end{aligned}$$

or the similarly defined $\mathcal{S}(M)$ and $\mathcal{S}_{n,k}(M)$ by using the tautological bundles $s\tau_{n,k}$. For every $f : M \rightarrow \mathfrak{G}_{n,k}$, the vector bundle $f^*\tau_{n,k}$ is associated to its *linear frame bundle* $f^*l\tau_{n,k}$, provided that both are considered as $\mathrm{GL}(k, \mathbb{R})$ -bundle. By the reduction from $\mathrm{GL}(k, \mathbb{R})$ to $O(k)$, then $f^*\tau_{n,k}$ is associated to its *orthogonal frame bundle* $f^*s\tau_{n,k}$, both considered as $O(k)$ -bundles. In particular by applying this to the tangent bundle $T(M)$ of a manifold, we get the linear or orthogonal *frame bundle* of M , say $F_l(M)$ or $F_s(M)$. M is parallelizable if and only if $F_l(M)$ (hence $F_s(M)$) has a section.

4.5. Limit tautological bundles

We will deal with a few concrete instances of the following general topological construction. Let $\{X_n\}_{n \in \mathbb{N}}$ be a countable family of Hausdorff topological spaces each admitting a countable basis of open sets. Assume that for every n , X_n is strictly contained in X_{n+1} as a closed subset. Then consider the “limit” space

$$X_\infty = \cup_n X_n$$

endowed with the *final topology* with respect to the family of inclusions

$$\{i_n : X_n \rightarrow X_\infty\};$$

this means the *finest* topology such that every i_n is continuous. In other words, A is open in X_∞ if and only if for every n , $A \cap X_n$ is open in X_n . We have

LEMMA 4.10. *If $K \subset X_\infty$ is compact then there is $n \in \mathbb{N}$ such that $K \subset X_n$.*

Proof : Assume that there is not, then there should be an infinite sequence x_n in K such that $x_n \in X_{n+1} \setminus X_n$. The union of these points of K would be a closed subset of K (hence compact) with induced discrete topology (i.e. it would be a *compact and discrete* space). Such a space is necessarily *finite* against our assumption. □

Some examples:

- $\mathbb{R}^n \subset \mathbb{R}^{n+1}$, $(x) \rightarrow (x, 0)$. Then we can define the limit space \mathbb{R}^∞ .

The above inclusions induce “equatorial” inclusions $i_n : S^{n-1} \rightarrow S^n$ of unit spheres, so we can define the limit space S^∞ .

- The definition of S^∞ can be generalized to arbitrary Stiefel manifolds. The inclusions $M(n, k, \mathbb{R}) \rightarrow M(n+1, k, \mathbb{R})$

$$A \rightarrow \begin{pmatrix} A \\ 0 \end{pmatrix}$$

induce inclusions of embedded smooth manifolds $i_n : S_{n,k} \rightarrow S_{n+1,k}$, and we can define the *Stiefel limit space* $S_{\infty,k}$.

- The inclusions $S(n, \mathbb{R}) \rightarrow S(n+1, \mathbb{R})$

$$A \rightarrow \begin{pmatrix} A & 0 \\ 0 & 0 \end{pmatrix}$$

induce the inclusions $j_n := j_{n,n+1} : \mathfrak{G}_{n,k} \rightarrow \mathfrak{G}_{n+1,k}$, and we can define the *limit grassmannian* $\mathfrak{G}_{\infty,k}$.

- Clearly we have the family of commutative diagrams of smooth maps

$$\begin{array}{ccc} S_{n,k} & \xrightarrow{i_n} & S_{n+1,k} \\ \downarrow s_{n,k} & & \downarrow s_{n+1,k} \\ \mathfrak{G}_{n,k} & \xrightarrow{j_n} & \mathfrak{G}_{n+1,k} \end{array}$$

so we can eventually define the “limit projection” which is continuous

$$\begin{array}{c} S_{\infty,k} \\ \downarrow s_{\infty,k} \\ \mathfrak{G}_{\infty,k} \end{array}$$

Similarly by using the linear frames we have the limit projection

$$\begin{array}{c} L_{\infty,k} \\ \downarrow l_{\infty,k} \\ \mathfrak{G}_{\infty,k} \end{array}$$

EXAMPLE 4.11. As a particular case we have the projection

$$s_{\infty,1} : S^{\infty} \rightarrow \mathbf{P}^{\infty}(\mathbb{R}) .$$

We easily realizes that s_{∞} is a continuous covering map of degree 2, alike every $s_{n,1}$. Thanks to lemma 4.10, for every $p \in \mathbb{N}$, every continuous map $f : S^p \rightarrow S^{\infty}$ is of the form $i_n \circ \tilde{f}$, for some $\tilde{f} : S^p \rightarrow S^n$ such that the image of \tilde{f} does not contain e_{n+1} . By considering $S^n = \mathbb{R}^n \cup \{\infty\}$ via the stereographic projection with center $\infty := e_{n+1}$, then \tilde{f} factorizes through a map with values in \mathbb{R}^n which is contractible. We can conclude that every such a map f is *homotopically trivial*. In other words all homotopy groups $\pi_p(S^{\infty})$ are trivial. By a theorem of Whitehead (see [H]), it follows that S^{∞} is contractible, hence $s_{\infty} : S^{\infty} \rightarrow \mathbf{P}^{\infty}(\mathbb{R})$ is a *universal covering map*. By the theory of covering maps we eventually get that the fundamental group $\pi_1(\mathbf{P}^{\infty}(\mathbb{R})) \sim \mathbb{Z}/2\mathbb{Z}$, while all other groups $\pi_p(\mathbf{P}^{\infty}(\mathbb{R}))$, $p > 1$, are trivial. We summarize these facts by saying that $\mathbf{P}^{\infty}(\mathbb{R})$ is a $K(\mathbb{Z}/2\mathbb{Z}, 1)$ spaces.

• The same limit procedure applies to the tautological bundles. We have the family of commutative diagrams of smooth maps

$$\begin{array}{ccc} \mathcal{V}(\mathfrak{G}_{n,k}) & \xrightarrow{\tilde{j}_n} & \mathcal{V}(\mathfrak{G}_{n+1,k}) \\ \downarrow \tau_{n,k} & & \downarrow \tau_{n+1,k} \\ \mathfrak{G}_{n,k} & \xrightarrow{j_n} & \mathfrak{G}_{n+1,k} \end{array}$$

so we eventually define the “limit tautological vector bundle” :

$$\begin{array}{c} \mathcal{V}(\mathfrak{G}_{\infty,k}) \\ \downarrow \tau_{\infty,k} \\ \mathfrak{G}_{\infty,k} \end{array} .$$

Similarly we have the limit bundles

$$\begin{array}{ccc} \mathcal{L}(\mathfrak{G}_{\infty,k}) & & \mathcal{S}(\mathfrak{G}_{\infty,k}) \\ \downarrow l_{\infty,k} & & \downarrow s_{\infty,k} \\ \mathfrak{G}_{\infty,k} & & \mathfrak{G}_{\infty,k} \end{array}$$

4.6. A classification theorem for compact manifolds

In this section *we assume that M is compact*. By Lemma 4.10, $f \in \mathcal{C}^0(M, \mathfrak{G}_{\infty,k})$ if and only if there is a minimum n such that it factorizes through a continuous map

$$\hat{f} : M \rightarrow \mathfrak{G}_{n,k}$$

followed by the inclusion

$$j_{n,\infty} : \mathfrak{G}_{n,k} \rightarrow \mathfrak{G}_{\infty,k} .$$

So it makes sense to say that such a map f is *smooth* if \hat{f} is smooth in the usual sense. Moreover also the topologies on the spaces $\mathcal{E}(M, \mathfrak{G}_{n,k})$ pass to the limits, giving us the topological space $\mathcal{E}(M, \mathfrak{G}_{\infty,k})$ of such smooth maps. If f, \hat{f} are as before, we have

$$f^* \tau_{\infty,k} = \hat{f}^* \tau_{n,k}$$

provided that the we have incorporated the *canonical identifications* illustrated in section 4.3.1. Set

$$\mathcal{V}_k(M) := \{f^* \tau_{\infty,k}; f \in \mathcal{E}(M, \mathfrak{G}_{\infty,k})\} .$$

It is clear from the above considerations that the already defined space $\mathcal{V}(M)$ can be described as

$$\mathcal{V}(M) = \cup_{k=0}^{\infty} \mathcal{V}_k(M)$$

as well as

$$\mathcal{E}(M, \mathfrak{G}) = \cup_{k=0}^{\infty} \mathcal{E}(M, \mathfrak{G}_{\infty,k}) .$$

Thus we have rephrased in terms of these limits the surjective maps

$$(\cdot)^* : \mathcal{E}(M, \mathfrak{G}) \rightarrow \mathcal{V}(M)$$

$$[(\cdot)^*] : \mathcal{E}(M, \mathfrak{G}) \rightarrow \mathbf{V}_0(M)$$

and we stipulate that the target spaces are endowed with the *quotient topology*.

Given $f_0, f_1 \in \mathcal{E}(M, \mathfrak{G})$ we say that they are *smoothly homotopic* if $f_0, f_1 \in \mathcal{E}(M, \mathfrak{G}_{\infty,k})$ for some k , and are connected by a smooth homotopy $F \in \mathcal{E}(M \times [0, 1], \mathfrak{G}_{\infty,k})$, provided that $f_t := F|_{M \times \{t\}}$. As usual, this defines an equivalence relation on $\mathcal{E}(M, \mathfrak{G})$. Denote by $[M, \mathfrak{G}]$ the set of smoothly homotopy classes of maps of $\mathcal{E}(M, \mathfrak{G})$.

PROPOSITION 4.12. *Let M be an embedded compact smooth manifold. If $[f_0^* \tau_{\infty,k}] = [f_1^* \tau_{\infty,k}]$ in $\mathbf{V}_0(M)$, then f_0 and f_1 are homotopic. Hence it is well defined a surjective map*

$$\mathbf{v} : \mathbf{V}_0(M) \rightarrow [M, \mathfrak{G}], [f^* \tau_{\infty,k}] \rightarrow [f] .$$

Proof : We will provide two proofs.

First proof: If $[f_0^* \tau_{\infty,k}] = [f_1^* \tau_{\infty,k}] \in \mathbf{V}_0(M)$, we can assume that they both factorize through maps (for simplicity we keep the same names) $f_0, f_1 : M \rightarrow \mathfrak{G}_{n,k}$, for some n big enough. Moreover, sometimes we will confuse here a point $A \in \mathfrak{G}_{n,k}$ with the corresponding subspace $V_A \subset \mathbb{R}^n$. For $j = 0, 1$, for every $p \in M$, we have the direct sum decomposition $\mathbb{R}^n = f_j(p) \oplus f_j(p)^\perp$. The projections of the canonical basis $\{e_1, \dots, e_n\}$ onto $f_j(p)$, when p varies, define n -sections $s_{j,1}, \dots, s_{j,n}$ of $f_j^* \tau_{n,k}$ which span the fibre $f_j(p)$ over every $p \in M$. The map f_j can be reconstructed from these set of sections as follows: for every $p \in M$, the linear evaluation map

$$\mathbf{e}_{j,p} : \mathbb{R}^n \rightarrow f_j(p), \quad \mathbf{e}_{j,p}(X) = \sum_i x_i s_{j,i}(p)$$

is onto so that $\ker(\mathbf{e}_{j,p}) = f_j(p)^\perp$ and finally $f_j(p) = \ker(\mathbf{e}_{j,p})^\perp$. A strict equivalence from $f_0^* \tau_{n,k}$ to $f_1^* \tau_{n,k}$ transports the system of sections $s_{0,1}, \dots, s_{0,n}$ to a system $s'_{1,1}, \dots, s'_{1,n}$ over $f_1^* \tau_{n,k}$ which generate all its fibres. Denote by $\mathbf{e}'_{1,p}$ the corresponding evaluation maps and apply to it the above procedure in order to produce a map from M with value in $\mathfrak{G}_{n,k}$; we realize that this recovers f_0 . For every $p \in M$, $\ker(\mathbf{e}'_{1,p})$ is a graph of a linear map $L_p : f_1(p)^\perp \rightarrow f_1(p)$, while $f_1(p)^\perp$ itself is the graph of the zero map. The homotopy $L_{p,t} = tL_p$, $t \in [0, 1]$, eventually allows to define a desired homotopy between f_0 and f_1 .

Second proof: We know that f_j is determined by a map say g_j from $f_j^*(\mathcal{V}(\mathfrak{G}_{\infty,k}))$ to \mathbb{R}^∞ which is linear and injective at every fibre. Moreover, it factorizes through a map with value in some \mathbb{R}^k with k big enough. If $[f_0^* \tau_{\infty,k}] = [f_1^* \tau_{\infty,k}] \in \mathbf{V}_0(M)$, we can transport the map g_1 to a map g'_0 with such a property, defined on $f_0^*(\mathcal{V}(\mathfrak{G}_{\infty,k}))$ and we have to show that g_0 and g'_0 are homotopic through maps that are linear injections on fibers. First compose g_0 with the homotopy $a_t : \mathbb{R}^\infty \rightarrow \mathbb{R}^\infty$ defined by $a_t(x_1, x_2, \dots) = (1-t)(x_1, x_2, \dots) + t(x_1, 0, x_2, 0, \dots)$. This moves the image of g_0 into the odd-numbered coordinates. Similarly we can move g'_0 into the even-numbered coordinates. By keeping the names of these maps, we eventually define the desired homotopy $h_t = (1-t)g_0 + tg'_0$.

□

Finally we can answer Question 4.9, at least in the compact case. A similar classification theorem holds under more general assumptions. Compactness simplifies the proof and it will suffice to the aim of this text.

THEOREM 4.13. (Classification Theorem) *Let M be an embedded compact smooth manifold. Then the map*

$$\mathbf{v} : \mathbf{V}_0(M) \rightarrow [M, \mathfrak{G}], [f^* \tau_{\infty, k}] \rightarrow [f]$$

is bijective. That is for every $f_0, f_1 \in \mathcal{E}(M, \mathfrak{G})$, $[f_0^ \tau_{\infty, k}] = [f_1^* \tau_{\infty, k}] \in \mathbf{V}_0(M)$ if and only if f_0, f_1 are smoothly homotopic. Hence the map $[(\cdot)^*]$ induces the inverse map of \mathbf{v}*

$$\mathbf{c} : [M, \mathfrak{G}] \rightarrow \mathbf{V}_0(M), \mathbf{c}([f]) = [f^* \tau_{\infty, k}] \text{ whenever } f \in \mathcal{E}(M, \mathfrak{G}_{\infty, k}).$$

Proof : Thanks to Proposition 4.12, it is enough to prove that if f_0 and f_1 are homotopic, then $f_0^* \tau_{\infty, k}$ and $f_1^* \tau_{\infty, k}$ are strictly equivalent. We can assume that a homotopy factorizes through $F : M \times [0, 1] \rightarrow \mathfrak{G}_{n, k}$, n big enough. Take the pull-back $F^* \tau_{n, k}$. The idea is to use it in order to connect $f_0^* \tau_{n, k}$ and $f_1^* \tau_{n, k}$ by a path $f_t^* \tau_{n, k}$ of bundles strictly equivalent to each other. For every $t \in [0, 1]$, $p \in M$, denote by $V_{t, p}$ the fibre of $f_t^* \tau_{n, k}$ over p .

Claim 1. *There is $\epsilon > 0$ such that for every $t \leq \epsilon$, $f_0^* \tau_{n, k}$ is strictly equivalent to $f_t^* \tau_{n, k}$.*

To prove it, recall the elementary fact that if $\mathbb{R}^n = V' \oplus V = V'' \oplus V$ (V, V' and V'' being linear subspaces), then $\phi : V' \rightarrow V''$, $\phi(v') = v''$ if $v' = v'' + v$, is a canonical linear isomorphism between V' and V'' . We have:

Claim 2. *There is $\epsilon > 0$ such that for every $0 \leq t \leq \epsilon$, for every $p \in M$, $\mathbb{R}^n = V_{0, p} \oplus V_{0, p}^\perp = V_{t, p} \oplus V_{0, p}^\perp$.*

Assuming **Claim 2**, then, for every $t \leq \epsilon$, the “field” of canonical isomorphisms

$$\phi_p : V_{t, p} \rightarrow V_{0, p}$$

when p varies in M , defines a strict equivalence, as required by **Claim 1**. Let us prove **Claim 2**. If such an ϵ does not exist by compactness there would exist a converging sequence $(p_n, t_n) \rightarrow (p_0, 0)$ in $M \times [0, 1]$, such that for every n , $\dim V_{t_n, p_n} \cap V_{0, p_n}^\perp > 0$. But this is impossible because $V_{0, p_0} \cap V_{0, p_0}^\perp = \{0\}$ and this is an open condition.

Set $\epsilon_0 \in [0, 1]$ the sup of the ϵ 's verifying **Claim 1**. We claim furthermore that ϵ_0 is a *maximum*. In fact by applying the same argument, we see that there is $\epsilon > 0$ such that $f_{\epsilon_0}^* \tau_{n, k}$ is strictly equivalent to $f_t^* \tau_{n, k}$, for $t \in (\epsilon_0 - \epsilon, \epsilon_0]$. Finally we claim that $\epsilon_0 = 1$: if $\epsilon_0 < 1$, we can apply again the above argument to f_{ϵ_0} and find $\epsilon_1 = \epsilon_0 + \epsilon$, for some small $\epsilon > 0$, which works as well, against the fact that ϵ_0 is the maximum.

□

• *The above discussion can be repeated word by word, getting similar conclusions, by dealing with embeded frame bundles and using the limit tautological bundles $l\tau_{\infty, k}$ or $s\tau_{\infty, k}$, $\mathcal{L}(M)$ or $\mathcal{S}(M)$.*

4.7. The rings of stable equivalence classes of vector bundles

The final aim of this section is to endow a suitable quotient space $\mathbf{K}_0(M)$ of $\mathbf{V}_0(M)$ with a natural *ring* structure, for every embedded smooth manifold M . This leads to a contravariant functor from the category of embedded smooth manifolds to the category of commutative rings. If M is compact we point out more information such as the invariance up to homotopy of the functor.

4.7.1. Grassmannian operations. The operations of the ring $\mathbf{K}_0(M)$ will descend from simple ‘operations’ defined between Grassmann manifolds.

- The inclusion $S(n, \mathbb{R}) \rightarrow S(n+m, \mathbb{R})$

$$A \rightarrow \begin{pmatrix} A & 0 \\ 0 & 0 \end{pmatrix}$$

induces for every $k \leq n$, a smooth inclusion

$$j_{n,n+m} : \mathfrak{G}_{n,k} \rightarrow \mathfrak{G}_{n+m,k} .$$

- The inclusion $S(n, \mathbb{R}) \times S(m, \mathbb{R}) \rightarrow S(n+m, \mathbb{R})$

$$(A, B) \rightarrow \begin{pmatrix} A & 0 \\ 0 & B \end{pmatrix}$$

induces for every $k \leq n$, $h \leq m$ a smooth inclusion

$$\oplus_{n,k,m,h} : \mathfrak{G}_{n,k} \times \mathfrak{G}_{m,h} \rightarrow \mathfrak{G}_{n+m,k+h} .$$

- For every $V \in G_{n,k}$ denote by V^* its dual spaces. Recall that this is considered as a subspace of $(\mathbb{R}^n)^* = M(n, 1, \mathbb{R})$ as follows. Let $\mathbb{R}^n = V \oplus V^\perp$ the orthogonal direct sum decomposition, $V^\perp \in G_{n,n-k}$ being the orthogonal complement of V with respect to the standard euclidean scalar product. Then extend every $\gamma \in V^*$ to a functional defined on the whole of \mathbb{R}^n by setting $\gamma(u+w) = \gamma(u)$. $M(n, 1, \mathbb{R})$ is canonically isomorphic to \mathbb{R}^n via the transposition.

Let $(V, W) \in G_{n,k} \times G_{m,h}$. Denote by $V \otimes W$ the space of bilinear forms defined on $V^* \times W^*$. Its dimension is kh . In fact there is the canonical bilinear map

$$\otimes : V \times W \rightarrow V \otimes W, \quad v \otimes w(\gamma, \rho) := \gamma(v)\rho(w)$$

and for every couple of bases $(\mathcal{B}, \mathcal{D})$ of V and W respectively, then $\mathcal{B} \otimes \mathcal{D} = \{v_i \otimes w_j; v_i \in \mathcal{B}, w_j \in \mathcal{D}\}$ is a basis of $V \otimes W$. By using the decomposition

$$\mathbb{R}^n \times \mathbb{R}^m = (V \oplus V^\perp) \times (W \oplus W^\perp)$$

and arguing as above we can consider $V \otimes W$ as a subspace of $\mathbb{R}^n \otimes \mathbb{R}^m$, hence (via canonical isomorphisms) as an element of $G_{nm, kh}$. In this way we have defined a map (between *sets*):

$$G_{n,k} \times G_{m,h} \rightarrow G_{nm, kh} .$$

This can be transported to a map

$$\otimes_{n,k,m,h} : \mathfrak{G}_{n,k} \times \mathfrak{G}_{m,h} \rightarrow \mathfrak{G}_{nm, kh}$$

via the usual bijections $V \rightarrow A_V, \dots$. One can check by direct computation that this is a *smooth map* between embedded smooth manifolds.

Similarly one can check that the set map

$$G_{n,k} \rightarrow G_{n,n-k}, \quad V \rightarrow V^\perp$$

induces a *diffeomorphism*

$$\perp_{n,k} : \mathfrak{G}_{n,k} \rightarrow \mathfrak{G}_{n,n-k}$$

with inverse $\perp_{n,n-k}$.

4.7.2. The ring $\mathbf{K}_0(M)$. The grassmannian operations of Section 4.7.1 induce operations

$$\begin{aligned} \oplus : \mathcal{V}(M) \times \mathcal{V}(M) &\rightarrow \mathcal{V}(M), \quad f^* \tau_{n,k} \oplus g^* \tau_{r,s} = (\oplus \circ (f, g))^* \tau_{n+r, k+s} \\ \otimes : \mathcal{V}(M) \times \mathcal{V}(M) &\rightarrow \mathcal{V}(M), \quad f^* \tau_{n,k} \otimes g^* \tau_{r,s} = (\otimes \circ (f, g))^* \tau_{nr, ks} \\ \perp : \mathcal{V}(M) &\rightarrow \mathcal{V}(M), \quad \perp (f^* \tau_{n,k}) = (\perp \circ f)^* \tau_{n, n-k} . \end{aligned}$$

The operations \oplus, \otimes, \perp descend to each quotient set $\mathcal{V}(M)/\text{Aut}(M)$, $\mathbf{V}(M)$ and $\mathbf{V}_0(M)$.

The grassmannian operations \oplus and \otimes pass to the limits:

$$\begin{aligned} \oplus : \mathfrak{G}_{\infty, k} \times \mathfrak{G}_{\infty, h} &\rightarrow \mathfrak{G}_{\infty, k+h} \\ \otimes : \mathfrak{G}_{\infty, k} \times \mathfrak{G}_{\infty, h} &\rightarrow \mathfrak{G}_{\infty, kh} \end{aligned}$$

and are continuous in the limit topology. The operation \perp induces in fact a family of continuous maps

$$\perp_n : \mathfrak{G}_{\infty, k} \rightarrow \mathfrak{G}_{\infty, n-k}, \quad n \geq k .$$

For every embedded smooth manifold M , these operations define a *ring* structure on a suitable quotient of $\mathbf{V}_0(M)$ that we are going to point out. Denote by ϵ^k the class in $\mathbf{V}_0(M)$ of the trivial (product) bundle $M \times \mathbb{R}^k \rightarrow M$. Clearly

$$\epsilon^k \oplus \epsilon^h = \epsilon^{k+h} .$$

DEFINITION 4.14. We say that ξ and η in $\mathbf{V}_0(M)$ are *weakly stably equivalent* if there exist ϵ^k and ϵ^h such that

$$\xi \oplus \epsilon^k = \eta \oplus \epsilon^h .$$

This is an equivalence relation indeed. Let us just check the transitivity. If

$$\xi \oplus \epsilon^k = \eta \oplus \epsilon^h, \quad \eta \oplus \epsilon^r = \beta \oplus \epsilon^s$$

then

$$\xi \oplus \epsilon^{k+r} = \beta \oplus \epsilon^{h+s} .$$

EXAMPLE 4.15. (1) Let M be a smooth manifold with non empty boundary ∂M . Let $i : \partial M \rightarrow M$ the inclusion. Then $T(\partial M)$ and $i^*T(M)$ are weakly stably equivalent vector bundles on ∂M . Fix any riemannian metric g on M . For every $x \in \partial M$, consider $\nu(x) = (T_x \partial M)^{\perp_{g(x)}}$; as $T_x M = \nu(x) \oplus T_x \partial M$, this defines a vector bundle ν on ∂M , with 1-dimensional fibres, such that $i^*T(M) = \nu \oplus T(\partial M)$. The bundle ν has a nowhere vanishing section (for every $x \in \partial M$ take the “outgoing” g -unitary vector in $\nu(x)$). Then $[\nu] = \epsilon^1$. In particular $S^n = \partial B^{n+1}(0, 1)$, $T(B^{n+1})$ is trivial as it is the restriction of $T(\mathbb{R}^{n+1})$, hence $[T(S^n)]$ is weakly stably trivial.

Denote by $\mathbf{K}_0(M)$ the quotient of $\mathbf{V}_0(M)$ up to weakly stable equivalence. It is clear that if $M = \{p\}$ is one point, then $\mathbf{K}_0(\{p\}) = 0$.

PROPOSITION 4.16. *The operations \oplus, \otimes descend to $\mathbf{K}_0(M)$ and make it an abelian ring.*

Proof : Associativity of \oplus is evident. The weakly stable equivalence class $[\epsilon^1]$ is the zero element; for every $[[\xi]]$, assume that $\xi \in \mathcal{V}_{n,k}(M)$, then $\xi^\perp \in \mathcal{V}_{n, n-k}(M)$ is such that

$$[\xi \oplus \xi^\perp] = \epsilon^n$$

hence

$$[[\xi^\perp]] = -[[\xi]] .$$

With a bit of more work one can also check the ring structure. We leave it as an exercise. □

Summing up

$$M \Rightarrow \mathbf{K}_0(M)$$

$$g : N \rightarrow M \Rightarrow g^\bullet : \mathbf{K}_0(M) \rightarrow \mathbf{K}_0(N), \quad g^\bullet([[f^* \tau_{\infty, k}]]) = [[(f \circ g)^* \tau_{\infty, k}]]$$

define a *contravariant functor from the category of embedded smooth manifolds (with boundary) to the category of abelian rings*.

If M is *compact*, the above construction of the ring $\mathbf{K}_0(M)$ from $\mathbf{V}_0(M)$ can be rephrased in terms of $[M, \mathfrak{G}]$. So: $[f_0]$, $f_0 : M \rightarrow \mathfrak{G}_{\infty, s}$, and $[f_1]$, $f_1 : M \rightarrow \mathfrak{G}_{\infty, r}$, are weakly stably equivalent if and only if there are constant maps $c_0 : M \rightarrow \mathfrak{G}_{\infty, k}$, $c_1 : M \rightarrow \mathfrak{G}_{\infty, h}$, such that $[\oplus \circ (f_0, c_0)] = [\oplus \circ (f_1, c_1)]$ in $[M, \mathfrak{G}]$. Denote by $[[M, \mathfrak{G}]]_0$ the quotient set. We have

PROPOSITION 4.17. *Let M be compact. The operations \oplus and \otimes descend to $[[M, \mathfrak{G}]]_0$ and make it an abelian ring such that the map \mathfrak{v} induces a ring isomorphism*

$$\tilde{\mathfrak{v}} : \mathbf{K}_0(M) \rightarrow [[M, \mathfrak{G}]]_0$$

with inverse

$$\tilde{\mathfrak{c}} : [[M, \mathfrak{G}]]_0 \rightarrow \mathbf{K}_0(M)$$

induced by the map \mathfrak{c} of the Classification Theorem 4.13.

□

COROLLARY 4.18. (Homotopy invariance) *Let M, N be compact smooth manifolds. Then:*

(1) *If $g_1, g_2 \in \mathcal{E}(N, M)$ are smoothly homotopic, then $g_1^\bullet = g_2^\bullet$.*

(2) *If M and N are smoothly homotopically equivalent, then $\mathbf{K}_0(M)$ and $\mathbf{K}_0(N)$ are isomorphic. In particular if M is smoothly contractible, then $\mathbf{K}_0(M) \sim \mathbf{K}_0(\{p\}) = 0$.*

Proof : (1) and (2) follows from the Classification Theorem, as $[[*, \mathfrak{G}]]_0$ is manifestly homotopically invariant.

□

We conclude this Section with a few scattered remarks.

REMARKS 4.19. (1) $\mathbf{K}_0(*)$ is a versions in our embedded smooth framework of so called *reduced topological K-theory* [A] [B]. Taking into account, for simplicity, only the additive structure, the *unreduced* group say $\mathbf{K}(M)$ is constructed as follows. First we consider the quotient say $\tilde{\mathbf{V}}_0(M)$ of $\mathbf{V}_0(M)$ up to *stable equivalence*; this is defined similarly to the above *weak stable equivalence* by imposing in the definition that $k = h$. The operation \oplus passes to the quotient, so that $(\tilde{\mathbf{V}}_0(M), \oplus)$ is a *commutative monoid* with (the class of) ϵ^0 as zero element.

$(\tilde{\mathbf{V}}_0(M), \oplus)$ verifies the “cancellation rule”.

In fact, if $\xi \oplus \eta = \xi \oplus \alpha$, we know that there exists β such that $\xi \oplus \beta = [\epsilon^n]$ (for some n), hence $[\epsilon^n] \oplus \eta = [\epsilon^n] \oplus \alpha$ and finally $\eta = \alpha$.

Then $\mathbf{K}(M)$ is the *Grothendieck group* of this monoid with cancellation rule. It is a general construction (producing for instance $(\mathbb{Z}, +)$ from $(\mathbb{N}, +)$) that works as follows. Consider the product $\tilde{\mathbf{V}}_0(M) \times \tilde{\mathbf{V}}_0(M)$; often an element (ξ, η) is written as a formal difference $\xi - \eta$. Put on this product the equivalence relation such that

$$\xi - \eta \sim \alpha - \beta$$

if and only if

$$\xi \oplus \beta = \alpha \oplus \eta .$$

The cancellation rule is used to check that it is actually an equivalence relation. The addition rule on the quotient $\mathbf{K}(M)$ naturally is

$$(\xi - \eta) \oplus (\alpha - \beta) = \xi \oplus \alpha - \eta \oplus \beta ;$$

the zero element is given by

$$[\epsilon^0] - [\epsilon^0] = \xi - \xi, \quad \forall \xi \in \tilde{\mathbf{V}}_0(M) ;$$

The inverse of $\xi - \eta$ is $\eta - \xi$.

Every element of $\mathbf{K}(M)$ can be represented by a difference of the form $\xi - [\epsilon^n]$ (for some n).

In fact, for every $\alpha - \beta$, let $\beta \oplus \gamma = [\epsilon^n]$, then

$$\alpha - \beta = \alpha \oplus \gamma - \beta \oplus \gamma := \xi - [\epsilon^n] .$$

The correspondence $\xi - [\epsilon^n] \rightarrow \xi$ induces a canonical surjective homomorphism $\mathbf{K}(M) \rightarrow \mathbf{K}_0(M)$. It is well defined because if $\xi - [\epsilon^n] = \xi' - [\epsilon^m]$ in $\mathbf{K}(M)$, then $\xi \oplus [\epsilon^m] = \xi' \oplus [\epsilon^n]$, hence $\xi = \xi'$ in $\mathbf{K}_0(M)$. The kernel consists of the elements of the form $[\epsilon^n] - [\epsilon^m]$ which is isomorphic to \mathbb{Z} so that $\mathbf{K}(M) \sim \mathbf{K}_0(M) \oplus \mathbb{Z}$ (in a non canonical way).

(2) If M is compact, the construction of $\mathbf{K}(M)$ from $\mathbf{V}_0(M)$ can be rephrased in terms of $[M, \mathfrak{G}]$. This produces a group (a ring indeed) $[[M, \mathfrak{G}]]$ which is isomorphic to $\mathbf{K}(M)$, via the Classification Theorem (similarly to Proposition 4.17). Hence also the functor

$$\begin{aligned} M &\Rightarrow \mathbf{K}(M) \\ &\dots \Rightarrow \dots \end{aligned}$$

verifies the *homotopy invariance* properties, similarly to Corollary 4.18.

(3) We can develop the very same constructions by using the complex grassmannians $\mathfrak{G}_{n,k}(\mathbb{C})$ and the complex vector bundles; this leads to the functors

$$\begin{aligned} M &\Rightarrow \mathbf{K}_0(M, \mathbb{C}), \mathbf{K}(M, \mathbb{C}) \\ &\dots \Rightarrow \dots \end{aligned}$$

(4) *Bott's periodicity theorem* [B], [At] is among the fundamental results in this theory. Let us just recall a few related statements that we can formulate in our setting.

- For every compact M , $\mathbf{K}(M \times S^2, \mathbb{C}) \sim \mathbf{K}(S^2, \mathbb{C}) \otimes \mathbf{K}(M, \mathbb{C})$;
- $\mathbf{K}(S^2, \mathbb{C}) = \mathbb{Z}[X]/(X - 1)^2$ where X is the tautological complex bundle over $\mathbf{P}^1(\mathbb{C})$ (recall that $\mathbf{P}^1(\mathbb{C})$ is diffeomorphic to S^2 , the “Riemann sphere”);
- For every $m \geq 1$, $\mathbf{K}_0(S^{m+8}) \sim \mathbf{K}_0(S^m)$, $\mathbf{K}_0(S^{m+2}, \mathbb{C}) \sim \mathbf{K}_0(S^m, \mathbb{C})$.

(5) **On real algebraic vector bundles.** We have shown that every Grassmann manifold $\mathfrak{G}_{n,k}$ is also a regular real algebraic set. Dealing with real algebraic sets, say $X \subset \mathbb{R}^n$, $Y \subset \mathbb{R}^m$, a natural class of maps $\mathcal{R}(X, Y)$ consists of so called *regular rational maps* (shortly “algebraic”) that is restriction of rational maps $r : \mathbb{R}^n \rightarrow \mathbb{R}^m$, whose denominators nowhere vanish on X . Consider the tautological vector bundle

$$\tau_{n,k} : \mathcal{V}(\mathfrak{G}_{n,k}) \rightarrow \mathfrak{G}_{n,k} .$$

It is immediate that also the total space $\mathcal{V}(\mathfrak{G}_{n,k})$ is a regular algebraic set, and that $\tau_{n,k}$ is algebraic. Moreover, if M is any regular real algebraic sets, and

$$f : M \rightarrow \mathfrak{G}_{n,k}$$

is an algebraic map, then one readily checks that also the pull-back $f^*\tau_{n,k}$ verifies the same properties. So we can consider the family of *algebraic vector bundles* on M

$$\mathcal{V}^{\text{alg}}(M) = \cup_{(n,k) \in \mathcal{N}} \mathcal{V}_{n,k}^{\text{alg}}(M)$$

where we consider only the pull-back via algebraic maps. The operations \oplus , \otimes , \perp restrict algebraically. We can also consider $\mathbf{V}_0^{\text{alg}}(M)$ where we impose that the strict equivalence are realized by algebraic map. Many constructions developed so far have a natural “algebraic” specialization (for instance we have $\mathbf{K}_0^{\text{alg}}(M)$, $\mathbf{K}^{\text{alg}}(M)$). By forgetting the algebraic structure and keeping only the one of smooth manifold, we have natural forgetting maps

$$\mathcal{V}^{\text{alg}}(M) \rightarrow \mathcal{V}(M), \mathbf{V}_0^{\text{alg}}(M) \rightarrow \mathbf{V}_0(M), \dots, \mathbf{K}^{\text{alg}}(M) \rightarrow \mathbf{K}(M)$$

and natural interesting questions (injective, surjective, \dots , ?) whose answers presumably depend on the real algebraic structure. On another hand, it is not so evident how to formulate an algebraic version of the Classification Theorem (for example our proof that smooth homotopy defines an equivalence relation used the bump function, and this is not very “algebraic” indeed).

Similar algebraic specialization holds also for the frame tautological bundles.

Compact embedded smooth manifolds

The hypothesis that an embedded smooth manifold M is *compact* usually simplifies the study of several objects associated to it. A first example has been the proof of the Classification Theorem of embedded vector bundles in Chapter 4. We will develop this theme, by considering first a few technical device.

5.1. Nice atlas and finite partitions of unity

Let M be an embedded smooth m -manifold (possibly with boundary). Recall that a normal chart (W, ϕ) of M is either contained in the interior of M and of the form

$$\phi : W \rightarrow B^m(0, 1)$$

or it intersects ∂M and is of the relative form

$$\phi(W, W \cap \partial M) \rightarrow (B^m(0, 1) \cap \mathbf{H}^m, B^m(0, 1) \cap \partial \mathbf{H}^m) .$$

The bump function (recall Section 1.12)

$$\gamma = \gamma_{1/3, 1/2} : B^m(0, 1) \rightarrow \mathbb{R}$$

lifts to a *global bump function*

$$\gamma_W : M \rightarrow \mathbb{R}$$

with compact support

$$S_W = \phi^{-1}(\bar{B}^m(0, 1/2)) \subset W .$$

Denote by

$$B_W = \phi^{-1}(B^m(0, 1/3)) \subset S_W .$$

B_W is a relatively compact open set in M .

DEFINITION 5.1. Let M be a compact embedded smooth manifold.

(1) A *nice atlas* of M is a finite atlas $\mathcal{U} = \{(W_j, \phi_j)\}_{j=1, \dots, s}$ formed by normal charts, such that the family $\{B_j\}$ ($B_j := B_{W_j}$) is a open covering of M .

(2) Set $\gamma_j := \gamma_{W_j}$,

$$\lambda_j := \frac{\gamma_j}{\sum_j \gamma_j}$$

so that

$$\sum_j \lambda_j = 1 .$$

Then $\{\lambda_j\}_{j=1, \dots, s}$ is the (finite) *partition of unity* subordinate to the nice atlas \mathcal{U} .

It is clear that every compact M admits nice atlas. In fact we will use nice atlas *adapted* to a determined situation or to the solution of a determined problem. Note for example that the finite partitions of unity of \mathbb{R}^n involving a bump function at infinity used in Section 1.12, are in fact restriction of partitions of unity subordinate to a nice atlas of S^n , provided that

$$\mathbb{R}^n \subset \mathbb{R}^n \cup \{\infty\} = S^n$$

via a stereographic projection.

5.2. Spaces of maps with compact source manifold

We adopt the notations of Section 2.4. The so called *weak topology* is completely adequate when the source manifold is compact, as it allows a complete global control over the whole of M . In fact, let $f \in \mathcal{E}^r(M, N)$. Let \mathcal{U} be a nice atlas of M such that every (W_j, ϕ_j) carries a local representation f_j of f . Consider the neighbourhoods of f of the form

$$\mathcal{U}_r(f, f_j, \bar{B}_j, \epsilon) .$$

Then every

$$\cap_j \mathcal{U}_r(f, f_j, \bar{B}_j, \epsilon)$$

is an open neighbourhood of f , and by varying $\epsilon > 0$ we get a *basis of neighbourhoods* of f because

$$\cup_j \bar{B}_j = M .$$

Equivalently, in a more “embedded fashion”: assume $M \subset \mathbb{R}^h$, $N \subset \mathbb{R}^k$. Let \mathcal{U} be a nice atlas of M such that every (W_j, ϕ_j) supports a local smooth extension $g : \Omega_j \rightarrow \mathbb{R}^k$ of f . We can also assume that $\mathbb{R}^h \subset S^h$ as above, and that the Ω_j are part of a nice atlas $\tilde{\mathcal{U}}$ of S^h (which restrict to the nice atlas of M). By using the partition of unity subordinate to $\tilde{\mathcal{U}}$ we show that f has a *global* smooth extension \hat{f} to the whole of \mathbb{R}^h . Then, by varying $\epsilon > 0$, we have a basis of neighbourhoods of f of the form

$$\mathcal{U}_r(f, \hat{f}, M, \epsilon) .$$

Let us study now some remarkable subsets of $\mathcal{E}^r(M, N)$, $r \geq 1$ or $\mathcal{E}(M, N)$.

LEMMA 5.2. *Let M be compact. Then $f : M \rightarrow N$ is an embedding if and only if it is an injective immersion.*

Proof : One implication is evident. We know that the other is in general false without the compactness. To prove it recall that in a compact (Hausdorff) space a subset is compact if and only if it is closed, and that a continuous map sends compact sets to compact sets; it follows that since M is compact, then f is closed so that f^{-1} is continuous and f is a homeomorphism onto its image in N . □

We have

PROPOSITION 5.3. *Assume that M is compact. Then the subsets of immersions, summersions, embeddings, diffeomorphisms are (possibly empty) open sets in $\mathcal{E}^r(M, N)$, $r \geq 1$ and in $\mathcal{E}(M, N)$.*

Proof : An immersion or summersion f is characterized by the condition of maximum rank of $d_x f$ at every $x \in M$. If g belongs to a neighbourhood of f in $\mathcal{E}^r(M, N)$, $r \geq 1$ giving a global control on the whole of M as above (with $\epsilon > 0$ small enough) then g verifies the same maximum rank condition. As for embeddings, thanks to Lemma 5.2 it is enough to prove that if g is close enough to an injective immersion f then also g is so. Assume that this thesis fails. Then there would exist a sequence $g_n \in \mathcal{C}^\infty(M, N)$, sequences of points x_n, y_n in M such that:

- (1) Every g_n is an immersion;
- (2) $g_n \rightarrow f$ and $dg_n \rightarrow df$ uniformly on M ;
- (3) $x_n \rightarrow x, y_n \rightarrow y$ in M , $x_n \neq y_n$ and $g_n(x_n) = g_n(y_n)$ for every n .

Then: $g_n(x_n) \rightarrow f(x), g_n(y_n) \rightarrow f(y)$, hence $x = y$ because f is injective. Then we can localize the situation in a chart of M at x and conclude (getting a contradiction) by applying the local Proposition 20.1.6. Finally if f is a diffeomorphism, in particular it is an embedding, hence g close to f is an embedding. It is enough to prove that g is onto. It is not restrictive to assume that M is connected, so that also N is connected. As an embedding g is an open map, its image is open in N ; on

another hand the image of g is compact hence closed because M is compact. Then the image of g coincides with the whole of N .

□

5.3. Tubular neighbourhoods and collars

Let $M \subset \mathbb{R}^h$ be a compact boundaryless smooth m -manifold. Let \mathbb{R}^h be endowed with the standard riemannian metric g_0 . Let us perform the following construction.

- (1) Consider the smooth map

$$\nu : M \rightarrow \mathfrak{G}_{h,h-m}$$

where for every $p \in M$, $\nu(p)$ is the (matrix corresponding to the) orthogonal space $(T_p M)^\perp$ (with respect to g_0).

- (2) Take the pull-back

$$\nu^* \tau_{h,h-m} : \nu^*(\mathcal{V}(\mathfrak{G}_{h,h-m})) \rightarrow M .$$

Every fibre $\nu(p)$ of this vector bundle is endowed with the restriction of g_0 . We consider $M \subset \nu^*(\mathcal{V}(\mathfrak{G}_{h,h-m}))$ via the canonical “zero section”.

- (3) Define the smooth map

$$f_\nu : \nu^*(\mathcal{V}(\mathfrak{G}_{h,h-m})) \rightarrow \mathbb{R}^h, \quad f_\nu(p, v) = p + v .$$

For every $\epsilon > 0$, set

$$N_\epsilon(M) = \{(p, v) \in \nu^*(\mathcal{V}(\mathfrak{G}_{h,h-m})); \|v\|_{g_0} \leq \epsilon\} .$$

It is immediate to verify that

- $f_\nu(p) = f_\nu(p, 0) = p$, for very $p \in M$;
- there exists $\epsilon > 0$ small enough such that the restriction of f_ν to $N_\epsilon(M)$ is an immersion. In fact, $\dim \nu^*(\mathcal{V}(\mathfrak{G}_{h,h-m})) = \dim \mathbb{R}^h$, and for every $x = (p, 0)$, the image of $d_x f_\nu$ is equal to $T_p M \oplus \nu(p) = T_p \mathbb{R}^h = \mathbb{R}^h$, so that f_ν is an immersion at M and the claim follows by the compactness of M .

- (4) There exists $\epsilon > 0$ small enough, such that the restriction (we keep the name)

$$f_\nu : N_\epsilon(M) \rightarrow \mathbb{R}^h$$

is an embedding onto a compact h -submanifold of \mathbb{R}^h with boundary, containing M in its interior. We already know that for $\epsilon > 0$ small enough, f_ν is an immersion; it is enough to prove that it is also injective. As it is the identity on M , and M is compact, this follows from the same argument used above to show that the embeddings form an open set.

- (5) Set

$$U := f_\nu(N_\epsilon(M)) \subset \mathbb{R}^h$$

$$p : U \rightarrow M, \quad p := \nu^* \tau_{h,h-m} \circ (f_\nu)^{-1} .$$

Let us analyze the arbitrary or inessential choices made in order to perform this construction.

- Certainly ϵ is not unique.
- The standard metric g_0 has nothing special from a topological differential view point (we made a similar consideration when we discussed the unitary tangent bundles). In fact the construction works as well by starting with an *arbitrary* riemannian metric g on \mathbb{R}^h .

- What we have really used of the map ν is that it defines a *transverse distribution of $(h - m)$ -planes along M* , that is for every $p \in M$,

$$\mathbb{R}^h = T_p M \oplus \nu(p) .$$

However, this is a fake generalization because it is not hard to prove, by using as usual $\mathbb{R}^h \subset S^h$ and suitable nice atlas, that for every such a transverse distribution, there is a riemannian metric g on \mathbb{R}^h that realizes it.

Summing up, we can vary the metric g and the final choice of $\epsilon > 0$. Let us call *tubular neighbourhood of M in \mathbb{R}^h* any couple (U, p) obtained by any implementation of the construction. We have the following *uniqueness up to isotopy* of these tubular neighbourhoods. Fix a auxiliary *base* tubular neighbourhood say (U^*, p^*) constructed by using the standard g_0 and some ϵ_0 . We have

PROPOSITION 5.4. *Let $M \subset \mathbb{R}^h$ be a compact boundaryless m -manifold. Let (U, p) be a tubular neighbourhood of M in \mathbb{R}^h . Then there is a smooth map*

$$H : U^* \times [0, 1] \rightarrow \mathbb{R}^h$$

such that for every $t \in [0, 1]$,

- (1) H_t is an embedding of U^* onto $U_t \subset \mathbb{R}^h$;
- (2) H_t is equal to id_M on M ;
- (3) (U_t, p_t) is a tubular neighbourhood of M in \mathbb{R}^h where $p_t := p^* \circ H_t^{-1}$.

Moreover

- (4) $H_0 = \text{id}_{U^*}$;
- (5) $(U_1, p_1) = (U, p)$.

Proof : If (U, p) differs from (U^*, p^*) only by $\epsilon \neq \epsilon_0$, the statement is clearly true (use a radial isotopy fibre by fibre). Assume that (U, p) has been constructed by using a metric g . Take the path of riemannian metrics $g_t = (1 - t)g_0 + tg$, $t \in [0, 1]$. Then there is a “path” of tubular neighbourhoods (U_t, p_t) constructed by using g_t and some $\epsilon_t > 0$. We can also assume that ϵ_t is a smooth function of t , and that $\epsilon_1 = \epsilon$. Hence we have the family of embeddings

$$f_{\nu_t} : N_{\epsilon_t}(M, g_t) \rightarrow \mathbb{R}^h .$$

There is also a family of strict equivalences $[\text{id}_M, \rho_t]$ between $\nu_0^* \tau_{h, h-m}$ and $\nu_t^* \tau_{h, h-m}$ given for every $t \in [0, 1]$ by the “field” of canonical linear isomorphisms

$$\nu_0(p) \rightarrow \nu_t(p), \quad p \in M$$

associated to the two direct sum decompositions

$$\mathbb{R}^h = T_p M \oplus \nu_0(p) = T_p M \oplus \nu_t(p) .$$

We can assume (we are free to change ϵ_0) that for every t ,

$$\rho_t(N_{\epsilon_0}(M, g_0)) \subset N_{\epsilon_t}(M, g_t)$$

and we can define the embeddings

$$f_{\nu_t} \circ \beta_t \circ (f_{\nu_0})^{-1} : U^* \rightarrow U_t .$$

This can be transformed to H_t with the required properties by composing it with radial isotopies fibre by fibre. □

REMARK 5.5. The above constructions work as well if M is compact with non empty boundary ∂M . The resulting tubular “neighbourhoods” (U, p) are not really neighbourhoods of M in \mathbb{R}^h . Rather they are submanifolds with corners of \mathbb{R}^h , containing $(M, \partial M)$ as a proper submanifold.

5.3.1. Tubular neighbourhoods of submanifolds. Assume now that $Y \subset M \subset \mathbb{R}^h$, $\dim Y = s$, $\dim M = m$, $s < m$, M and Y compact. Assume also that M and Y are boundaryless. Fix a riemannian metric g on \mathbb{R}^h . As above, we have the associated maps

$$\begin{aligned}\nu_M &: M \rightarrow \mathfrak{G}_{h,h-m} \\ \nu_Y &: Y \rightarrow \mathfrak{G}_{h,h-s} .\end{aligned}$$

Set for every $y \in Y$,

$$\hat{\nu}_Y(y) := \nu_Y(y) \cap T_y M .$$

This define a smooth map

$$\hat{\nu}_Y : Y \rightarrow \mathfrak{G}_{h,m-s} .$$

Define

$$f_{\hat{\nu}_Y} : \hat{\nu}_Y^*(\mathcal{V}(\mathfrak{G}_{h,m-s})) \rightarrow \mathbb{R}^h, \quad f_{\hat{\nu}_Y}(y, v) = y + v .$$

Let (U_M, p_M) be a tubular neighbourhood of M constructed by means of ν_M . There is $\epsilon > 0$ small enough such that the image via $f_{\hat{\nu}_Y}$ of

$$\hat{N}_\epsilon(Y, g) = \{(y, v) \in \hat{\nu}_Y^*(\mathcal{V}(\mathfrak{G}_{h,m-s})); \|v\|_g \leq \epsilon\}$$

is contained in U_M . Finally define

$$f_{Y,M} : \hat{N}_\epsilon(Y, g) \rightarrow M, \quad f_{Y,M} := p_M \circ f_{\hat{\nu}_Y} .$$

Arguing similarly as made above for f_ν , this verifies

- $f_{Y,M}(y) = f_{Y,M}(y, 0) = y$, for every $y \in Y$;
- there exists $\epsilon > 0$ small enough such that the restriction of $f_{Y,M}$ to $\hat{N}_\epsilon(Y, g)$ is an immersion.
- In fact, there is $\epsilon > 0$ small enough such that the restriction of $f_{Y,M}$ to $\hat{N}_\epsilon(Y, g)$ is an embedding onto a neighbourhood $U_{Y,M}$ of Y in M .

Finally $(U_{Y,M}, p_{Y,M})$, where $p_{Y,M} = \hat{\nu}_Y^* \tau_{h,m-s} \circ (f_{Y,M})^{-1}$ is by definition a *tubular neighbourhood of Y in M* .

• By varying g and ϵ , we have again the *uniqueness of these tubular neighbourhoods of Y in M up to isotopy*. We leave the details to the reader.

5.3.2. Collars. Consider now $M \subset \mathbb{R}^h$ compact with non empty boundary ∂M . We would apply the above construction, by considering ∂M as a “monolateral” submanifold of M . By keeping the above notations, we know that

$$\hat{\nu}_{\partial M}^*(\mathcal{V}(\mathfrak{G}_{h,1}))$$

is strictly equivalent to the product bundle

$$\partial M \times \mathbb{R} \rightarrow \partial M$$

and a section is given by the unitary “positive” v (write “ $v > 0$ ”), that is pointing towards the interior of M . So we can define

$$\hat{N}_\epsilon^+(\partial M, g) = \{(y, v) \in \hat{\nu}_{\partial M}^*(\mathcal{V}(\mathfrak{G}_{h,1})); \|v\|_g \leq \epsilon, \text{ “}v \geq 0\text{”}\} .$$

By using it, the construction can be repeated and we eventually get (by definition) a *collar* of ∂M into M , that is an embedding $C : \partial M \times [0, \epsilon] \rightarrow M$ which is the identity on ∂M . Again we have the *unicity of collars up to isotopy*.

REMARK 5.6. In the construction of the collars, it is not necessary that the whole M is compact, it is enough that ∂M is so.

REMARK 5.7. Assume that $Y \subset M \in \mathbb{R}^h$ are compact manifolds with boundary such that Y is a *proper* submanifold of M . Then we can apply again the above construction to get tubular neighbourhoods of Y in M *relative* to the boundaries, that is which restrict to tubular neighbourhoods of ∂Y in ∂M .

Tubular neighbourhoods have several interesting applications. Here is a simple one. Assume that $M \subset \mathbb{R}^h$ is compact. We already know (by using the partitions of unity) that every $f \in \mathcal{E}(M, N)$, $N \subset \mathbb{R}^k$, extends to a smooth map $\hat{f} : U \rightarrow \mathbb{R}^k$ defined on a neighbourhood of M in \mathbb{R}^h . Let (U, p) be a tubular neighbourhood of M . Then $f \circ p : U \rightarrow N$ is a smooth extension of f with values in N .

5.4. Proper embedding and “double” of manifolds with boundary

Let $M \subset \mathbb{R}^h$ be a compact smooth manifold with $\partial M \neq \emptyset$. The existence of collars suggests a variant in the definition of nice atlas.

DEFINITION 5.8. A *nice atlas with collar* of $(M, \partial M)$ is of the form

$$\{(W_\partial, \phi_\partial)\} \cup \{(W_j, \phi_j)\}_{j=1, \dots, s}$$

where

- (1) W_∂ is an open neighbourhood of ∂M and

$$\phi_\partial : W_\partial \rightarrow \partial M \times [0, 1)$$

is a diffeomorphism which is equal to the identity on ∂M . Denote by $B_\partial := \phi_\partial^{-1}([0, 1/3))$.

- (2) Every (W_j, ϕ_j) is a normal chart contained in the interior of M , and $B_j \subset W_j$ is defined as for the usual nice atlas.
 (3) $\{B_\partial\} \cup \{B_j\}$ is an open covering of M . The existence of nice atlas with collar is a direct consequence of the existence of collars.

Given such a nice atlas with collar, every W_j carries a global bump function $\gamma_j : M \rightarrow \mathbb{R}$ as in Definition 5.1. Define the *collar global bump function*

$$\gamma_\partial : M \rightarrow \mathbb{R}$$

such that on W_∂ it is equal to $\gamma \circ p_{[0,1]} \circ \phi_\partial$, where $p_{[0,1]} : \partial M \times [0, 1) \rightarrow [0, 1)$ is the projection, and γ is the restriction to $[0, 1)$ of the 1-dimensional bump function $\gamma_{1/3, 1/2}$; on $M \setminus W_\partial$, γ_∂ is constantly equal to 0. Define

$$\lambda_\partial = \frac{\gamma_\partial}{\gamma_\partial + \sum_{i=1}^s \gamma_i}$$

$$\lambda_j = \frac{\gamma_j}{\gamma_\partial + \sum_{i=1}^s \gamma_i} .$$

Then the family of functions

$$\{\lambda_\partial\} \cup \{\lambda_j\}_{j=1, \dots, s}$$

is the *partition of unity* subordinate to the given nice atlas with collar.

COROLLARY 5.9. *For every compact manifold M with non empty boundary there is a smooth function $f : M \rightarrow [0, 1]$ such that $\partial M = f^{-1}(0)$ and f is a summersion on a neighbourhood of ∂M .*

Proof : Take a nice atlas with collar. Define locally the following functions

$$f_\partial : W_\partial \rightarrow \mathbb{R}, \quad f_\partial = p_{[0,1]} \circ \phi_\partial ;$$

$$f_j : W_j \rightarrow \mathbb{R}, \quad f_j(x) = 1/2, \quad \forall x \in W_j .$$

Finally set

$$f = \lambda_\partial f_\partial + \sum_j \lambda_j f_j .$$

It is not hard to verify that it is smooth and verifies the required properties. \square

The following is an easy generalization

COROLLARY 5.10. *Let M be a compact manifold with boundary ∂M equipped with a partition $\partial M = N_0 \cup N_1$, where both N_0 and N_1 are union of connected components of ∂M . Then there exists a smooth function $f : M \rightarrow [0, 1]$ such that $f^{-1}(0) = N_0$, $f^{-1}(1) = N_1$, and f is a summersion on a neighbourhood of ∂M .*

□

REMARK 5.11. To get the above corollaries we can even use a simpler covering of M consisting of $(W_\partial, \phi_\partial)$ as above together with an open set of the form $U = M \setminus W'$ where $W' \subset W_\partial$ is a smaller compact collar of ∂M contained in B_∂ . Hence $W' \subset W'' \subset B_\partial$, where W'' is another collar of ∂M , so that the compact sets B_∂ and $B'_\partial := M \setminus W''$ cover M . By playing with collar bump functions and variants we get smooth functions γ_∂ and γ'_∂ defined on M where γ_∂ is as above, while γ'_∂ is equal to 1 on B'_∂ and is equal to 0 on W' ; $\lambda_\partial, \lambda'_\partial$ denote the functions of the associated smooth partition of unity. Then to prove for instance Corollary 5.9 define f_∂ as above, f_U constantly equal to $1/2$ on U and finally take $f = \lambda_\partial f_\partial + \lambda'_\partial f_U$.

PROPOSITION 5.12. *Let $M \subset \mathbb{R}^h$ be a compact smooth m -manifold with boundary ∂M . Then there is a diffeomorphism $\beta : M \rightarrow M' \subset \mathbb{R}^n$ (some n big enough) such that $(M', \partial M')$ is a proper submanifold of $(\mathbf{H}^n, \partial \mathbf{H}^n)$.*

Proof : Take a nice atlas with collar. Define

$$\begin{aligned} \beta &= (\beta_\partial, \beta_1, \dots, \beta_s) : M \rightarrow (\mathbb{R}^h \times \mathbb{R}) \times (\mathbb{R}^m \times \mathbb{R})^s := \mathbb{R}^n \\ \beta_\partial &= (\lambda_\partial \phi_\partial, \lambda_\partial) \\ \beta_j &= (\lambda_j \phi_j, \lambda_j) . \end{aligned}$$

We claim that this β works. To show that it is an embedding it is enough to prove that it is an injective immersion. It is an immersion because every $x \in M$ belongs either to B_∂ or to some B_j . The restriction of either $\lambda_\partial \beta_\partial$ or $\lambda_j \beta_j$ is ϕ_∂ or ϕ_j . In any case it is an injective immersion, so β is a fortiori an immersion. As for the injectivity, let $x \neq y$. If both belong to either B_∂ or some B_j , then they are already separated by $\lambda_\partial \beta_\partial$ or $\lambda_j \beta_j$. Otherwise they are separated by either λ_∂ or some λ_j . Hence β is injective. Finally it follows by the construction that the image M' of β is contained in \mathbf{H}^n and that $\partial \mathbf{H}^n$ intersects transversely M' at $\partial M = \partial M'$ (in fact $\partial M = \partial M'$ is contained in $\partial \mathbf{H}^n$, and there is a small $\epsilon > 0$ such that

$$M' \cap \{x \in \mathbf{H}^n; x_n < \epsilon\} = \partial M \times [0, \epsilon] .$$

□

REMARKS 5.13. (1) Corollary 5.9 is also a consequence of Proposition 5.12. In fact f given by the composition of β with the projection onto the x_n coordinate has the required property with value in some $[0, a)$, $a > 0$, and to get $[0, 1]$ is just a simple question of reparametrization.

(2) A proof of Proposition 5.12 can be obtained by using the open covering with associated partition of unity of Remark 5.11. For one can take

$$\beta = (\beta_\partial, \beta_U) : M \rightarrow (\mathbb{R}^h \times \mathbb{R}) \times (\mathbb{R}^h \times \mathbb{R})$$

where β_∂ is as above, $\beta_U = (\lambda'_\partial j_U, \lambda'_\partial)$ and j_U is the inclusion of M into \mathbb{R}^h .

The double of M . Let $M' \subset \mathbb{R}^n$ be obtained from M as in the proof of Proposition 5.12. Let M'' be the image of M' via the reflection

$$(x_1, \dots, x_n) \rightarrow (x_1, \dots, -x_n) ;$$

$\partial M' = \partial M'' = \partial M$. Also M'' is diffeomorphic to M and is a proper submanifold of $\{x_n \leq 0\}$. Then $D(M) := M' \cup M''$ is compact smooth *boundaryless* manifold, containing both M' and M'' as submanifolds. ∂M is given by the *transverse intersection* of $D(M)$ with $\partial \mathbf{H}^n$. Considered up to diffeomorphism $D(M)$ only depends

on M (also considered up to diffeomorphism). In this sense it is called the *double of M* .

5.5. A fibration theorem

PROPOSITION 5.14. (Fibration Theorem) *Let M be a compact boundaryless smooth manifold and $f : M \rightarrow N$ a surjective summersion onto the connected manifold N . Let $q_0 \in N$, $F = f^{-1}(q_0)$. Then f is a smooth fibre bundle with fibre F .*

Proof : Let $q_0 \in N$ and $F = f^{-1}(q_0)$. We know that F is a submanifold of M . Fix a tubular neighbourhood (U, p) of F in M . Let D be a small open disk in N around q_0 such that $f^{-1}(D) \subset U$. Define $h : f^{-1}(D) \rightarrow F \times D$, $h(x) = (f(x), p(x))$. Clearly, $f = p_D \circ h$, where p_D is the projection onto D . Moreover, $h(x) = (x, 0)$ for every $x \in F$. As f is a summersion, it is easy to verify that the differential of h is invertible on $f^{-1}(D)$ (possibly shrinking D). As h is essentially the identity on F , and the fibres are compact, an usual argument (for instance like in the construction of the tubular neighbourhoods) shows that if D is small enough, h is a diffeomorphism, hence a local trivialization of f . If q is an arbitrary point of N , we can cover a smooth arc joining q_0 and q in N by a “chain” of similar local trivializations over a chain $D = D_0, D_1, \dots, D_k, D_k$ around q , of small disks centred at the arc, $D_j \cap D_{j+1} \neq \emptyset$, so that one eventually deduces that the fibre F' over q_1 is diffeomorphic to F . Finally we have proved that f is a smooth fibration with fibre F . □

5.6. Density of smooth among C^r -maps

Recall that for every $r \geq 0$, $\mathcal{C}^r(M, N)$ denotes the space of C^r maps endowed with the weak topology; $\mathcal{E}^r(M, N)$ is the subspace of smooth maps. We have

PROPOSITION 5.15. *Assume that $M \subset \mathbb{R}^h$, $N \subset \mathbb{R}^k$ are boundaryless compact smooth manifolds. Then for every $r \geq 0$, $\mathcal{E}^r(M, N)$ is dense in $\mathcal{C}^r(M, N)$.*

Proof : Let (U_M, p_M) and (U_N, p_N) be respective tubular neighbourhoods. Let $(U, p) \subset (U_M, p_M)$ be a smaller tubular neighbourhood (it just differs by a smaller “ ϵ ”, so that p is the restriction of p_M). Let $f \in \mathcal{C}^r(M, N)$. Consider the C^r extension $\hat{f} = f \circ p_M$. Apply Stone-Weierstrass Theorem 1.7 to get a *polynomial* map $P : U_M \rightarrow \mathbb{R}^k$ which uniformly approximates (in the C^r -topology) \hat{f} on U (which is compact); we can also require that $P(U) \subset U_N$. Finally the restriction to M of $p_N \circ P$ is a *smooth* map from M to N which approximates f in the C^r -topology. □

By a very similar argument we have also

LEMMA 5.16. *Let $M \subset \mathbb{R}^h$, $N \subset \mathbb{R}^k$ be compact boundaryless manifolds. If $f \in \mathcal{E}^r(M, N)$ is close enough to $g \in \mathcal{C}^r(M, N)$ then they are C^r -homotopic. If they are both smooth then they are smoothly homotopic.*

Proof : If f is close enough to g we can assume that for every $p \in M$, for every $t \in [0, 1]$, $(1-t)g(p) + tf(p)$ belongs to U_N . Then $H(p, t) = p_N((1-t)g(p) + tf(p))$ is a required homotopy. □

REMARK 5.17. By using Remark 5.5, Proposition 5.15 and Lemma 5.16 hold true if N is the interior of a compact manifold with boundary \bar{N} . Clearly they hold also if N is an open set of \mathbb{R}^k

5.7. Smooth homotopy groups - Vector bundles on spheres

The above results have the following important application. Fundamental topological-algebraic invariants, the *homotopy groups* $\pi_n(X)$, $n \geq 1$ (considered up to isomorphism) are defined for every path connected topological space X in terms of *continuous homotopy* classes of *continuous* maps $S^n \rightarrow X$. If $X = N \subset \mathbb{R}^k$ is as in above Remark 5.17, then Proposition 5.15 and Lemma 5.16 imply that we can equivalently define the homotopy groups of N by using *smooth* maps $S^n \rightarrow N$ up to *smooth* homotopy. If it is necessary to deal with pointed maps, we can do it by using the smooth homogeneity of N .

Let us use these facts to classify (up to strict equivalence) the embedded vector bundles on a unit sphere $S^m \subset \mathbb{R}^{m+1}$, $m \geq 2$. Let $\xi = f^* \tau_{n,k}$, for some smooth map $f : S^m \rightarrow \mathfrak{G}_{n,k}$. Let us fix $1 > \epsilon > 0$. Set $D^+ = S^m \cup \{x_{m+1} \geq -\epsilon\}$, $D^- = S^m \cup \{x_{m+1} \leq \epsilon\}$. Clearly, both D^\pm are diffeomorphic to a closed m -disk, $S^m = D^+ \cup D^-$, $D^+ \cap D^-$ is a tubular neighbourhood of the equatorial sphere $S^{m-1} \subset S^m$, diffeomorphic to $S^{m-1} \times [-1, 1]$. We know by the Classification Theorem that the pull-back of ξ on D^\pm via the respective inclusion maps is strictly equivalent to the product bundle $D^\pm \times \mathbb{R}^k \rightarrow D^\pm$. Fix two respective trivializations. The change of trivialization on $D^+ \cap D^-$ produces a smooth map

$$\rho_\xi : D^+ \cap D^- \rightarrow \text{GL}(k, \mathbb{R})$$

and we consider its restriction (we keep the name)

$$\rho_\xi : S^{m-1} \rightarrow \text{GL}(k, \mathbb{R}) .$$

As $D^+ \cap D^-$ is connected, the image of ρ_ξ is contained in one of the two connected components of $\text{GL}(k, \mathbb{R})$ and up to strict equivalence we can assume that this is the subgroup $\text{GL}^+(k, \mathbb{R})$. The arbitrary choices made to define ρ_ξ are the positive scalar ϵ , the representative ξ in its strict equivalence class, the two trivializations. It is easy to verify (by using the Classification Theorem) that the homotopy class $[\rho_\xi]$ does not depend on these choices so we have well defined a map

$$\mathbf{V}_{0,k}(S^m) \rightarrow [S^{m-1}, \text{GL}(k, \mathbb{R})], [\xi] \rightarrow [\rho_{[\xi]}] .$$

If $m - 1 > 1$, the (smooth) $\pi_{m-1}(\text{GL}^+(k, \mathbb{R}))$ is abelian, the choice of a base point is immaterial, so that $[\rho_{[\xi]}] \in \pi_{m-1}(\text{GL}^+(k, \mathbb{R}))$. If $m = 2$, we have to take into account the base points say $p_0 = e_1$ of S^1 and say $x_0 = I_k$ of $\text{GL}^+(k, \mathbb{R})$ and work with *pointed* smooth maps. However this is a minor technical point, we can manage it by using the smooth homogeneity of $\text{GL}^+(k, \mathbb{R})$ (we skip the details), so that we can eventually consider again $[\rho_{[\xi]}] \in \pi_1(\text{GL}^+(k, \mathbb{R}))$. Summing up, for every $m \geq 2$, for every $k \geq 1$, we have defined a map

$$\rho : \mathbf{V}_{0,k}(S^m) \rightarrow \pi_{m-1}(\text{GL}^+(k, \mathbb{R})) .$$

We claim that *this map is bijective*. In fact we can exhibit ρ^{-1} . This will be a particular case of Proposition 6.9, see Section 6.3.1.

REMARK 5.18. The same construction works as well for complex embedded smooth vector bundles on S^m , by replacing $\text{GL}^+(k, \mathbb{R})$ with $\text{GL}(k, \mathbb{C})$ (which is connected), or also for bundles with “reduced group” like for instance $SO(k)$.

5.8. Smooth approximation of compact embedded C^r -manifolds

For every $r \geq 0$ there is a natural category of embedded C^r -manifolds and C^r -maps (C^r -diffeomorphisms) between them. When $r = 0$ we have the category of (embedded) *topological manifolds* and continuous maps (homeomorphisms). This presents its own phenomena (including “wild” ones) that are beyond the aims and the possibilities of this text. On another hand, we are going to see that to a large extent (at least in the compact case), for $r \geq 1$, there are not essentially new

phenomena with respect to the smooth category. Basically this depends on the density of smooth maps already established.

• For $r \geq 1$, let $M \subset \mathbb{R}^h$ be a boundaryless compact \mathcal{C}^r -manifold. The construction of the tubular neighbourhoods of M in \mathbb{R}^h works verbatim in the \mathcal{C}^r -category. It is enough to start with a \mathcal{C}^r -map $\nu : M \rightarrow \mathfrak{G}_{h,h-m}$ defining a distribution of transverse $(h-m)$ -planes along M . If we use for instance the standard metric g_0 on \mathbb{R}^h , we obtain only a \mathcal{C}^{r-1} -map. However by applying the same argument of the proof of Proposition 5.15 we can approximate it by a \mathcal{C}^r -map, keeping the transversality. Assume that we have fixed one (U, p) . We can summarize this by the following commutative diagrams (where for simplicity we have written τ instead of $\tau_{h,h-m}$):

$$\begin{array}{ccc} U & \xrightarrow{F} & \mathcal{V}(\mathfrak{G}_{h,h-m}) \\ \downarrow p & & \downarrow \tau \\ M & \xrightarrow{\nu} & \mathfrak{G}_{h,h-m} \end{array}$$

where $F = \nu^* \circ (f_\nu)^{-1}$. F is a \mathcal{C}^r -map and verifies the following properties (which are easy to check):

- $M = F^{-1}(\mathfrak{G}_{h,h-m})$, where $\mathfrak{G}_{h,h-m} \subset \mathcal{V}(\mathfrak{G}_{h,h-m})$ as the zero section.
- The image of F is contained in the interior of a compact submanifold with boundary of the form $N_\epsilon(\mathfrak{G}_{h,h-m})$ for some $\epsilon > 0$.
- F is *transverse to* $\mathfrak{G}_{h,h-m}$, that is for every $p \in M$,

$$T_{F(p)}\mathcal{V}(\mathfrak{G}_{h,h-m}) = T_{F(p)}\mathfrak{G}_{h,h-m} + d_p F(T_p U) .$$

This means that $M = F^{-1}(\mathfrak{G}_{h,h-m})$ can be considered as a sort of “global equation” defining M , which localizes in terms of very domestic equations: for every given triivialization $\Phi : \tau^{-1}(W) \rightarrow W \times \mathbb{R}^{h-m}$ of the tautological bundle, we can consider the restriction of $\Phi \circ F$ obtaining a map

$$(\Phi \circ F)^{-1}(W \times \mathbb{R}^{h-m}) \rightarrow W \times \mathbb{R}^{h-m} .$$

Let $\pi : W \times \mathbb{R}^{h-m} \rightarrow \mathbb{R}^{h-m}$ the projection. As F is transverse to $\mathfrak{G}_{h,h-m}$ then $\pi \circ \Phi \circ F$ is a summersion (possibly shrinking U), and

$$(\Phi \circ F)^{-1}(W \times \{0\}) = (\pi \circ \Phi \circ F)^{-1}(0) .$$

By the way this confirms that M is a submanifold of U of the correct dimension thanks to Proposition 2.12.

• By the density Theorem 5.15, see also Remark 5.17, we can uniformly approximate F (in the \mathcal{C}^r -topology) on a slightly smaller compact tubular neighbourhood $U' \subset U$ with a *smooth* map

$$\tilde{F} : U' \rightarrow \mathcal{V}(\mathfrak{G}_{h,h-m}) .$$

As the transversality is manifestly a \mathcal{C}^1 -open condition, if \tilde{F} is close enough to F , then it is transverse to $\mathfrak{G}_{h,h-m}$ and by applying to \tilde{F} the above construction and again Proposition 2.12, we conclude that $M' := \tilde{F}^{-1}(\mathfrak{G}_{h,h-m})$ is a compact submanifold of the interior of U' , $\dim M' = \dim M$. Moreover, If \tilde{F} is close enough to F then the restriction of p to M' defines a \mathcal{C}^r -diffeomorphism $\rho : M' \rightarrow M$. For as p is the identity on M this last claim follows by the very same argument used in the construction of the tubular neighbourhood to show that $f_\nu : N_\epsilon(M) \rightarrow U$ is a diffeomorphism. Note that M' can be *arbitrarily \mathcal{C}^r -close to* M in the sense that the \mathcal{C}^r -diffeomorphism $\rho^{-1} : M \rightarrow M'$ composed with the inclusion of M' in U' can be arbitrarily close to the inclusion of M of in U' .

Summing up:

PROPOSITION 5.19. (Smooth approximation theorem) *For every $r \geq 1$, for every embedded compact boundaryless C^r -manifold $M \subset \mathbb{R}^h$ there is a smooth manifold $M' \subset \mathbb{R}^h$ C^r -diffeomorphic to M . Moreover M' can be chosen arbitrarily C^r -close to M (i.e. M' is a smooth approximation of M in \mathbb{R}^h).*

These smooth structures are *unique up to diffeomorphism*. Precisely

PROPOSITION 5.20. (Uniqueness of smooth structure) *If M, N are compact boundaryless embedded smooth manifolds which are C^r -diffeomorphic, for some $r \geq 1$, then they are smoothly diffeomorphic.*

In fact, if $f : M \rightarrow N$ is a C^r -diffeomorphism, it can be approximated by a smooth map \tilde{f} which is an injective immersion (because $r \geq 1$), hence it is a diffeomorphism. □

5.9. Nash approximation of compact embedded smooth manifolds

By following carefully the above construction of \tilde{F} , we have more information about its “degree of smoothness”. Here we use some notions recalled in Section ???. We assume also that the reader has a few basic knowledge of real analytic maps. For the notions of real (semi)-algebraic geometry we refer to [BCR], [BR].

Let $X \subset \mathbb{R}^k$ be a compact regular real algebraic set of dimension r (as a smooth manifold). Let us specialize the construction of a tubular neighbourhood in this algebraic situation. If we use the standard metric g_0 on \mathbb{R}^k , then the associated map $\nu : X \rightarrow \mathfrak{G}_{k,k-r}$ is algebraic. The map $f_\nu : N_\epsilon(X) \rightarrow \mathbb{R}^k$ is algebraic. The pull-back bundle $\nu^*\tau$ is algebraic. Hence the tubular neighbourhood projection $p : U \rightarrow X$ is the composition of algebraic maps and of a map obtained by *inverting an algebraic map*. According to Remarks 5.5 and 5.17 these considerations hold also for the tubular neighbourhoods of a compact regular “semialgebraic” set with boundary, that is obtained as in Lemma 2.22, assuming that X is a regular real algebraic set and the function f is algebraic (so that also the boundary is a real algebraic set). Then such a projection p is not any smooth map. A basic example of function of this type is $y = \sqrt{1 + x^2}$ and we note that its graph is a branch of the hyperbole defined by the polynomial equation $y^2 - x^2 - 1 = 0$. We would say that it belongs to the *smallest class of maps containing the algebraic maps, closed by usual algebraic operations and for which the inverse map theorem and its corollaries hold true*. As algebraic maps are *real analytic*, and the inverse map theorem holds for real analytic maps, then p is at least *real analytic*. But we have more. Recall that by definition a *semialgebraic set* Y in some \mathbb{R}^n is definable as the union of a *finite* family of subsets of \mathbb{R}^n each one definable as the solution of a finite system of real polynomial inequalities. Obviously this extends the notion of algebraic set. Fixing a few technical issues, by developing these considerations one defines the subcategory of *Nash manifolds and maps* of the category of smooth embedded manifolds. A Nash m -manifold is an embedded real analytic m -manifold $M \subset \mathbb{R}^n$, for some n , which is also a semialgebraic set; in particular this implies that M is contained in a real algebraic set X of the same dimension. A Nash map $f : M \rightarrow N$ between Nash manifolds is a real analytic map such that its graph is a semialgebraic set. We say that a Nash manifold $M \subset \mathbb{R}^n$ is *normal* if it is contained in the regular part $R(X)$, X being as above. A normal compact boundaryless Nash manifold M is union of connected components of $R(X)$. Although semialgebraic and analytically smooth, in general M is not normal but it has a *normalization* up to Nash diffeomorphisms. More precisely we have the following very concrete description of Nash manifolds and maps (see [AM])

PROPOSITION 5.21. *Let $M \subset \mathbb{R}^n$ be a connected Nash m -manifold and $f : M \rightarrow \mathbb{R}^h$ be a Nash map. Then there are:*

- (1) An irreducible m -dimensional real algebraic set $X \subset \mathbb{R}^n \times \mathbb{R}^k$, for some k ;
- (2) A polynomial map $p : X \rightarrow \mathbb{R}^h$;
- (3) A Nash manifold $M' \subset M \times \mathbb{R}^k$, such that $M' \subset R(X)$, and it is the graph a Nash map $g : M \rightarrow \mathbb{R}^k$, so that $\sigma(x) = (x, g(x))$ is a Nash diffeomorphism;
- (4) $f = p \circ \sigma$.

□

If M and N are Nash manifolds, Nash maps form a subspace $\mathcal{N}^r(M, N)$ of $\mathcal{E}^r(M, N)$, for $r \geq 1$ and $\mathcal{N}(M, N)$ of $\mathcal{E}(M, N)$; thanks to the inverse map theorem which holds for Nash maps, a compact Nash manifold M has Nash tubular neighbourhoods (U, p) (U is a compact Nash manifold with boundary - possibly with corners - and p is a Nash map). With the very same proof of Proposition 5.15 we have the following *density of Nash maps*.

PROPOSITION 5.22. (Density of Nash maps) *Assume that $M \subset \mathbb{R}^h$, $N \subset \mathbb{R}^k$ are Nash manifolds, M compact boundaryless, N the interior of a compact \bar{N} . Then for every $r \geq 1$, $\mathcal{N}^r(M, N)$ is dense in $\mathcal{E}^r(M, N)$, $\mathcal{N}(M, N)$ in $\mathcal{E}(M, N)$.*

□

Let $M \subset \mathbb{R}^h$ be a compact smooth boundaryless m -manifold and consider again the commutative diagram

$$\begin{array}{ccc} U & \xrightarrow{F} & \mathcal{V}(\mathfrak{G}_{h, h-m}) \\ \downarrow p & & \downarrow \tau \\ M & \xrightarrow{\nu} & \mathfrak{G}_{h, h-m} \end{array}$$

$\mathfrak{G}_{h, h-m}$ is a regular real algebraic set, $N_\epsilon(\mathfrak{G}_{h, h-m})$ is a compact regular semi-algebraic set with boundary contained in the regular real algebraic set $\mathcal{V}(\mathfrak{G}_{h, h-m})$, hence we fix for it a Nash tubular neighbourhood say $(U_{\mathfrak{G}}, p_{\mathfrak{G}})$. The approximating map \tilde{F} is of the form

$$p_{\mathfrak{G}} \circ P$$

where P is a polynomial map (by application of Stone-Weirstrass); \tilde{F} is eventually a Nash map close to F , then $M' := \tilde{F}^{-1}(\mathfrak{G}_{h, h-m})$ is a Nash manifold \mathcal{C}^∞ -close to M . So by adapting the very same construction used to give a compact \mathcal{C}^r -manifold a smooth structure, we have the following celebrated result by J. Nash [Na]. A first approximation theorem in this vein is due to Seifert [Seif], concerning the case of manifolds with product tubular neighbourhood.

THEOREM 5.23. (1) (Nash approximation theorem) *Let $M \subset \mathbb{R}^h$ be a compact connected smooth boundaryless manifold. Then there is a Nash manifold $M' \subset \mathbb{R}^h$ diffeomorphic to M and which can be chosen arbitrarily \mathcal{C}^∞ -close to M . Up to stabilize the embedding $M \subset \mathbb{R}^h \subset \mathbb{R}^h \times \mathbb{R}^k$, for some suitable k , we can assume that the Nash approximation $M' \subset \mathbb{R}^{h+k}$ is normal, that is M' is union of connected components of $R(X)$, $X \subset \mathbb{R}^{h+k}$ being a real algebraic set of the same dimension.*

(2) (Uniqueness of Nash structures) *If two compact embedded boundaryless Nash manifolds $M \subset \mathbb{R}^h$, $N \subset \mathbb{R}^k$ are smoothly diffeomorphic, then they are Nash diffeomorphic to each other.*

□

REMARKS 5.24. (1) Let M be compact smooth with non empty boundary ∂M . We can apply the Nash approximation to a double $D(M)$ of M (realized in \mathbb{R}^n as above) and get a boundaryless Nash manifold $D(M)' \subset \mathbb{R}^n$ close to $D(M)$. Then $M' := D(M)' \cap \mathbf{H}^n$ is a Nash model (with boundary) of M .

(2) In his pyoneristic paper [Na], Nash stated also a few conjectures/questions towards potential improvements of his result. The most natural conjecture was

that M can be approximated by a regular real algebraic set. We will return on it in Section 17.5.3. Another question concerned the existence of *rational* real algebraic models, see also Sections 15.5, 19.9).

5.9.1. On Nash vector bundle. By using the classification theorem 4.13, the density of Nash maps, and Lemma 5.16 we readily have (details are left as an exercise) the following existence and uniqueness of Nash structures on smooth vector bundles. This answers in the Nash category the analogue of (more demanding) questions posed in Remark 4.19 (5) about real algebraic vector bundles.

PROPOSITION 5.25. *Let M be a compact embedded Nash manifold. Then*

- (1) *Every smooth embedded vector bundle on M is strictly equivalent to a Nash vector bundle.*
- (2) *If two Nash vector bundles on M are smoothly strictly equivalent, then they are Nash strictly equivalent to each other.*

REMARK 5.26. Beside its theoretic interest, approximation by Nash manifolds and density of Nash maps can be also of practical utility. Whenever we are interested in the density of smooth maps verifying a certain property, and we are in condition to apply Nash approximation and density of Nash maps, then it will be enough to show that Nash maps with the given property are dense among Nash maps. The main advantage is that we have a much stronger geometric control on the *image* of Nash than of arbitrary smooth maps. We will substantiate this remark in next sections.

The interested reader can find a lot of information about Nash manifolds in [BCR] and mostly in [Shi].

5.10. Smooth and Nash Sard-Brown theorem

Let us recall some facts of analysis.

- (i) Every open set $U \subset \mathbb{R}^n$ is endowed with the (n -dimensional) *Lebesgue measure* and this defines the class of *measure zero* i.e. *negligible* subsets of U .
- (ii) If $X \subset U$ is negligible and $f : U \rightarrow W$ is a \mathcal{C}^1 -map between open sets of \mathbb{R}^n , then $f(X)$ is negligible in W .
- (iii) If $U' \subset U$ is an open subset and X is negligible in U then $X \cap U'$ is negligible in U' .
- (iv) A countable union of negligible subsets of the open set U is negligible.
- (v) If X is negligible in the open set U , then $U \setminus X$ is dense in U .
- (vi) (*Fubini property*) If $U \subset \mathbb{R}^h \times \mathbb{R}^k$, $X \subset U$ and for every $a \in \mathbb{R}^h, X \cap \{a\} \times \mathbb{R}^k$ is negligible in $U \cap \{a\} \times \mathbb{R}^k$, then X is negligible in U .
- (vii) If M is a smooth embedded m -manifold, we say that $X \subset M$ is *negligible in M* if for every chart $\phi : W \rightarrow U \subset \mathbb{R}^m$, $\phi(X \cap W)$ is negligible in U . Thanks to the above properties of negligible sets it is enough to check it on the open sets of any countable atlas of M (which certainly exists). *We stress that we have not defined any measure on M , we have just defined the class of negligible subsets.*

Let $f : M \rightarrow N$ be a smooth map between embedded smooth manifolds of dimension m and n respectively. By definition a point $p \in M$ is *critical* for f if $\text{rank } d_p f < n = \dim N$. Set $C(f) \subset M$ the set of critical points of M .

$$N \setminus f(C(f)) \subset N$$

is the set of *regular values* of f while $q \in f(C(f))$ is said a *critical value* of f . The set $M \setminus C(f)$ is open (possibly empty) in M . If M is compact, $f(C(f))$ is compact,

hence closed in N . Sard's theorem is a fundamental result for differential topology; in particular it is the base of *transversality* theory that we will develop later.

THEOREM 5.27. (Sard's theorem) *Let $f : M \rightarrow N$ be a smooth map between embedded smooth manifolds. Then $f(C(f))$ is negligible in N .*

In fact in differential topological applications one rather uses the following corollary, also known as Brown's theorem.

COROLLARY 5.28. (Brown's theorem) *Let $f : M \rightarrow N$ be a smooth map between embedded smooth manifolds. Then $N \setminus f(C(f))$ is dense in N (open and dense if M is compact).*

Easy special cases. A special case of Sard's theorem is when $\dim M < \dim N$. Then $C(f) = M$. In this case the proof is easy: clearly M is negligible in $M \times \mathbb{R}^{n-m}$ and $f(M) = f \circ p_M(M) = f \circ p_M : M \times \mathbb{R}^{n-m} \rightarrow N$, p_M being the projection onto M . Then we can apply the above property (ii).

A special and immediate case of Brown's theorem is when M is the *finite* union of disjoint submanifolds of N of dimensions strictly less than $\dim N$, and f is the union of the inclusion maps. □

A very readable proof of Sard's theorem, which *fully* employs the fact that f is C^∞ , is in [M1]. We stress that it is a result of analytic nature and rather delicate. To appreciate better this point, let us recall the following Morse-Sard C^r generalization.

THEOREM 5.29. (Morse-Sard theorem) *Let $f : M \rightarrow N$ be a C^r -map between embedded smooth manifolds. If $r > \max\{0, m - n\}$ then $f(C(f))$ is negligible in N .*

The condition which relates the "degree of regularity" of f and the dimensions of the manifolds is sharp. Whitney [Whit] has constructed an example of a C^1 -function $f : \mathbb{R}^2 \rightarrow \mathbb{R}$ such that $C(f)$ contains a subset J homeomorphic to an open interval, and that f is not constant on J . Hence $f(C(f))$ contains an open interval. A proof of the Morse-Sard theorem can be found in [H].

5.10.1. A Sard-Brown theorem in the Nash category. Here is a Nash version of the Sard-Brown theorem, whose statement is purely geometric.

THEOREM 5.30. *Let $f : M \rightarrow N$ be a Nash map between embedded Nash manifolds. Then $f(C(f))$ is the union of a finite set of Nash submanifolds of N of dimensions strictly less than $\dim N$.*

REMARK 5.31. Assume that M and N are embedded smooth manifolds such that we can apply to both the Nash approximation by means of Nash manifolds M' and N' , so that $\mathcal{N}(M', N')$ is dense in $\mathcal{E}(M', N')$. It follows that the set of smooth maps $f : M \rightarrow N$ which verify Brown's theorem is dense in $\mathcal{E}(M, N)$. In many applications this suffices

Outline of a proof of Theorem 5.30. Alike the statement of the theorem, it is of purely geometric nature. For all details one can look at [BCR]. Let us recall the following basic facts about semialgebraic sets:

(1) We know that every embedded Nash manifold is in particular a semialgebraic set.

(2) Every semialgebraic set $X \subset \mathbb{R}^n$ is the union of a *finite* number of disjoint connected Nash embedded manifolds.

(3) If $X \subset M$ is a semialgebraic subset of the embedded Nash manifold M , and $f : M \rightarrow N$ is a Nash map between Nash manifolds, then $f(X)$ is a semialgebraic subset of N . This is a formulation adapted to our situation (and in fact a corollary)

of the celebrated *Tarski-Seidenberg theorem* that the projection in \mathbb{R}^{n-1} of a semi-algebraic set X in \mathbb{R}^n is a semi-algebraic set of \mathbb{R}^{n-1} . Moreover, all Nash manifolds making a partition of $f(X)$ as in (2) have dimension less or equal $\dim M$.

Let us come to the proof of Theorem 5.30. Let $f : M \rightarrow N$ be our Nash map between embedded Nash manifolds. As f is a Nash map, it is not hard to check that $C(f)$ is a semi-algebraic subset of M . By applying point (2), one realizes that $C(f)$ is the *finite* union of disjoint connected Nash submanifolds each one, say Y , verifying the following property: there exists $0 \leq k < \dim N$ such that for every $p \in Y$, $\text{rank } d_p f|_Y = k$. $f(C(f)) \subset N$ is the union of the images $f(Y)$'s hence it is a semi-algebraic subset of N . By point (2) again, it is the disjoint union of a finite number of disjoint connected Nash submanifolds of N . We claim that for every such a manifold, say Z , $\dim Z < \dim N$. If for example $N = \mathbb{R}$, then the restriction of f on every Y has vanishing differential, hence f is constant on Y , so that $f(C(f))$ is a *finite* subset of \mathbb{R} . In general we can assume that $Z \subset f(Y)$ for some Y as above, and $\dim Z = \dim N$ would be against the *constant rank theorem* 1.5. □

REMARK 5.32. We continue in the vein of Remark 5.26. The Nash Sard-Brown theorem is an important example of application of the stronger geometric control on the images of Nash maps. Merely *continuous* maps (between open sets of some euclidean space) can have “wild” behaviour (i.e. anti intuitive with respect to an “ordinary” geometric intuition). Let us recall for instance the so called *Peano’s curves*, i.e. *surjective* continuous maps $g : [0, 1] \rightarrow [0, 1]^2$. Wild phenomena make the category of topological manifolds much delicate to deal with. By Sard’s theorem (easy case) *there are not smooth Peano’s curves*. In the Nash situation, even better the image of any such a Nash g is a finite union of points or Nash 1-manifolds. Smooth maps (and manifolds), although much more “tame” than merely C^0 ones, are suited to topological considerations because they are very “flexible”. This is basically due to the existence of bump functions and the *flatness* phenomenon that they incorporate. On another hand, this also implies for example that subsets of a smooth manifold defined by a finite set of smooth equations or inequalities can be weird: for instance one can prove that *every* compact subset of \mathbb{R}^n can be realized as the zero set of a smooth function. In a sense this means that the formulation of the smooth Sard’s theorem in *measure* theoretic terms, is the best one can say in general about the image of the critical set. The situation is dramatically simpler and geometrically friendly in the Nash case. It can be profitable to combine the flexibility of smooth manifolds with the Nash approximation and the density of Nash maps (whenever they can be applied).

5.11. Morse functions via generic linear projections to lines

Let M be a compact boundaryless embedded smooth m -manifold.

DEFINITION 5.33. A smooth function $f : M \rightarrow \mathbb{R}$ is a *Morse function* if it has only non degenerate critical points.

According to Chapter 1, the notion of non degenerate critical point p of a determined *index* say λ can be defined on any representation in local coordinates of f at p (as it does not depend on the choice of the local coordinates). By Morse Lemma, the non degenerate critical points are isolated, hence by compactness every Morse function on M has only a finite number of critical points. At least one of them is certainly a minimum (of index $\lambda = 0$) at least one is a maximum (of index $\lambda = m$). A Morse function on M is *generic* if distinct critical points take distinct (critical) values. In such a case we can order the critical points p_0, p_2, \dots, p_r so that $c_j := f(p_j) < f(p_{j+1}) =: c_{j+1}$. Up to a linear reparametrization of the image, sometimes we assume also that $f(M) = [0, 1]$.

We want to prove that Morse functions exist and moreover are open and dense in $\mathcal{E}(M, \mathbb{R})$.

LEMMA 5.34. *Let $M \subset \mathbb{R}^h$ be a compact boundaryless smooth manifold. The set of Morse functions on M is open in $\mathcal{E}(M, \mathbb{R})$.*

Proof : Let $f : M \rightarrow \mathbb{R}$ be a Morse function, with critical points p_1, \dots, p_k . Fix a nice atlas of M such that every critical point p_j is contained in a B_j of some normal chart and these B_j 's are pairwise disjoint. If g is close enough to f (in the \mathcal{C}^1 topology) then it has no critical points on the compact set $M \setminus \cup_j B_j$. Let us analyze the local representation of f , say \hat{f}_j , defined on the compact set $\bar{U}_j := \phi_j(\bar{B}_j) \subset \mathbb{R}^m$, for every $j = 1, \dots, k$. On \bar{U}_j , the positive smooth function

$$a_{\hat{f}_j}(x) := \|d_x \hat{f}_j\|^2 + (\det(\frac{\partial^2 \hat{f}_j}{\partial x_i \partial x_j}(x)))^2$$

never vanishes, because the first term vanishes only at $0 = \phi(p_j)$, and the second term does not vanish because the critical point is non degenerate. By compactness, there is $d > 0$ such that, for every $x \in \bar{U}_j$, $a_{\hat{f}_j}(x) > d$. If g is close enough to f in the \mathcal{C}^2 topology, then $a_{\hat{g}_j}(x) > d/2$, hence also g has only non degenerate critical points on \bar{B}_j . As there is a finite number of critical points of f , we readily conclude that if g is close enough to f in the \mathcal{C}^2 topology, then g is a Morse function. \square

Let $M \subset \mathbb{R}^h$ be as above. For every linear function $L \in (\mathbb{R}^h)^*$,

$$L(x) = a_1 x_1 + \dots + a_h x_h$$

corresponding to $(a_1, \dots, a_h) \in M(1, h, \mathbb{R})$ consider the restriction L_M to M . We have

THEOREM 5.35. *Let $M \subset \mathbb{R}^h$ be a compact boundaryless smooth manifold. Then for every $f \in \mathcal{E}(M, \mathbb{R})$, there is a open dense subset \mathcal{L}_f of $(\mathbb{R}^h)^*$ such that for every $L \in \mathcal{L}_f$, $f + L_M$ is a Morse function.*

COROLLARY 5.36. *Let $M \subset \mathbb{R}^h$ be a compact boundaryless smooth manifold. Then:*

(1) *There is a open dense set \mathcal{L} in $(\mathbb{R}^h)^*$ such that for every $L \in \mathcal{L}$, L_M is a Morse function.*

(2) *The set of generic Morse functions is a open dense set in $\mathcal{E}(M, \mathbb{R})$.*

Proof of Corollary 5.36. (1) is a consequence of Theorem 5.35 applied to the constant function $f = 0$. Theorem 5.35 together with Lemma 5.34 implies that the set of Morse functions is open and dense in $\mathcal{E}(M, \mathbb{R})$ (if L is close to zero, then $f + L_M$ is close to f). It is evident that generic Morse functions form an open set in the set of Morse functions. Then it remains to show that generic Morse functions are dense. Let $f : M \rightarrow \mathbb{R}$ be a Morse function. Assume that there is a critical point p which shares the value with another one. It is enough to show that arbitrarily close to f there is a Morse function g with the same set of critical points of f , such that $g(p) \neq g(p')$ for any other critical point p' . Then we conclude by induction on the number of sharing value critical points. Let (W, ϕ) be a normal chart centred at p , such that W does not contains other critical points of f . Let γ be the global bump functions on M associated to this normal chart. For every $\epsilon \neq 0$, set $g_\epsilon = f + \epsilon\gamma$. Clearly, if $|\epsilon|$ is small enough, then g_ϵ is close to f (because M is compact), hence it is a Morse function. It is also clear that g_ϵ coincides with f outside the compact support of γ (contained in W). A discrepancy between the sets of critical points could only occur on the support of γ . But for every $x \in U$, $d_x \hat{g} = d_x \hat{f} + \epsilon d_x \gamma_{1/3, 1/2}$. On $B^m(0, 1/3)$ this reduces to $d_x \hat{f}$, hence p is the only

critical point of g_ϵ on $B \subset W$ (with the usual notations about normal charts). The function \hat{f} has no critical points on the compact set $\overline{B^m(0, 1/2)} \setminus \overline{B^m(0, 1/3)}$, hence if $|\epsilon| > 0$ is small enough the same fact holds for g_ϵ . Finally, by the finiteness of the critical set, it is clear that we can take $|\epsilon|$ small enough so that $g_\epsilon(p)$ differs from any other critical value. □

Proof of Theorem 5.35. By the Nash approximation theorem and the density of Nash functions it is not restrictive to assume that $M \subset \mathbb{R}^h$ is a Nash m -manifold, and that $f : M \rightarrow \mathbb{R}$ is a Nash function. We will give a proof based on the Nash version of Sard-Brown theorem. For a reader who would prefer a purely smooth proof, we will indicate in parallel how to manage it by means of the ordinary Sard-Brown theorem. Let us start with a local Lemma.

LEMMA 5.37. *Let $f : U := B^m(0, 1) \rightarrow \mathbb{R}$ be a Nash function. Then there is a negligible subset X of $(\mathbb{R}^m)^* \sim M(1, m, \mathbb{R})$ such that for every $L \in (\mathbb{R}^m)^* \setminus X$, $f + L_U$ is a Morse function.*

Proof : The differential

$$df : U \rightarrow M(1, m, \mathbb{R})$$

is a Nash map. For every L , for every $p \in U$, p is a critical point of $f + L_U$ if and only if $d_p f = -L$. $-L$ is regular value of df if and only if for every $p \in U$ such that $d_p f = -L$,

$$d_p(d_p f) = \left(\frac{\partial^2 f}{\partial x_i \partial x_j}(p) \right)_{i,j=1,\dots,m} \in M(m, \mathbb{R})$$

is invertible. Hence, $-L$ is a regular value of df if and only if all the critical points of $f + L_U$ are non degenerate, that is $f + L_U$ is a Morse function. We conclude by means of the Nash Sard-Brown theorem. □

In the smooth case we have the same Lemma with the same proof, by using the smooth Sard-Brown theorem.

Let $M \subset \mathbb{R}^h$ be a compact Nash m -manifold as above. M is covered by a finite set of Nash Monge charts (this depends on the compactness of M and on the inverse function theorem which holds in the Nash category). Possibly reordering the coordinates of \mathbb{R}^h , the corresponding Nash local Monge parametrization of M is of the form

$$U := B^m(0, 1) \rightarrow (x, \psi(x)) \in M \subset \mathbb{R}^m \times \mathbb{R}^{h-m}$$

so that the associated local representation of f is the Nash function

$$\hat{f}(x_1, \dots, x_m) = f(x_1, \dots, x_m, \psi(x_1, \dots, x_m)) .$$

Let us write every $L \in M(1, h)$ in the form

$$L(x) = (a_1 x_1 + \dots + a_m x_m) + (a_{m+1} x_{m+1} + \dots + a_h x_h) := \alpha(x_1, \dots, x_m) + \beta(x_{m+1}, \dots, x_h)$$

then the corresponding local representation of $f + L_M$ is

$$(\hat{f}(x_1, \dots, x_m) + \beta(\psi(x_1, \dots, x_m)) + \alpha(x_1, \dots, x_m)) := \hat{f}_\beta + \alpha_U .$$

For every fixed $\beta \in M(1, h - m, \mathbb{R})$, let us vary $\alpha \in M(1, m, \mathbb{R})$ and apply Lemma 5.37 to \hat{f}_β . Then for every β the subset $C_\beta \subset M(1, m, \mathbb{R})$ of α 's such that $\hat{f}_\beta + \alpha_U$ is not a Morse function consists of a finite number of disjoint Nash submanifolds of $M(1, m, \mathbb{R})$ of dimension $< m$. Also the subset C_f of $M(1, h)$ such that the restriction of $f + L_M$ to the given Monge chart is not Morse is a semialgebraic subset, hence it is the finite union of disjoint Nash submanifolds of $M(1, h, \mathbb{R})$. It is also the union of the slices C_β , β varying in $M(1, h - m, \mathbb{R})$. As every C_β is union

of manifolds of dimension $< m$, then C_f is union of manifolds of dimension $< h$. As there is a finite number of Monge charts, there is a finite number of such sets C_f in $M(1, h, \mathbb{R})$. The complement \mathcal{L}_f of their union is dense in $M(1, h, \mathbb{R})$ and for every $L \in \mathcal{L}_f$, $f + L_M$ is a Morse function.

In the smooth case, the dimensional consideration about C_f is replaced by the conclusion that it is negligible, by using this information about every slices and the Fubini property (vi) recalled at the beginning of this section. \square

5.11.1. Manifolds with boundary. Let M be a compact smooth manifold with boundary ∂M , and let us fix a partition $\partial M = V_0 \cup V_1$ as in Corollary 5.10. By this Corollary we know that the set, say $\mathcal{E}(M, V_0, V_1; \mathbb{R})$, of smooth functions $f : M \rightarrow [0, 1]$ such that $f^{-1}(j) = V_j$, $j = 0, 1$, and without critical points near ∂M is non empty. We can extend the results obtained in the boundaryless case.

PROPOSITION 5.38. *The generic Morse functions belonging to $\mathcal{E}(M, V_0, V_1; \mathbb{R})$ form an open dense set.*

The only point that needs some further considerations is the existence of such relative Morse functions. By using the notations of Remark 5.11, via the proper embeddings and the double of M , the results in the boundaryless case tell us that there are arbitrarily small linear projections L which restrict to Morse functions on U . If f belongs to $\mathcal{E}(M, V_0, V_1; \mathbb{R})$ and L is small enough, then $\lambda_\partial f + \lambda'_\partial L$ provides a Morse function closed to f ; details are left as an exercise. \square

5.12. Morse functions via distance functions

The use of generic linear projections to line is a geometrically transparent way to produce Morse functions on a compact embedded smooth manifold. Here we outline another natural way based on distance functions. Let $M \subset \mathbb{R}^h$ be compact boundaryless as usual. For every $q \in \mathbb{R}^h$ consider the smooth (actually polynomial) function

$$\delta_q : \mathbb{R}^h \rightarrow \mathbb{R}, \quad \delta_q(x) := \|x - q\|^2.$$

We have

THEOREM 5.39. *There is an open and dense set $\Omega \subset \mathbb{R}^h$ such that for every $q \in \Omega$, the restriction of δ_q to M is a Morse function.*

Sketch of proof. Consider $\nu : M \rightarrow \mathfrak{G}_{h, h-m}$ corresponding to the distribution of normal $(h - m)$ -planes with respect to the standard metric g_0 on \mathbb{R}^h . Let

$$f_\nu : \nu^*(\mathcal{V}(\mathfrak{G}_{h, h-m})) \rightarrow \mathbb{R}^h, \quad f_\nu(p, v) = p + v$$

be the map already used to construct a tubular neighbourhood of M in \mathbb{R}^h . One proves that the restriction of δ_q to M has some degenerate critical point if and only if q is not a regular value of f_ν (the reader can try to prove this by exercise; anyway all details can be found in [M2] Part 1-6). Then we conclude by applying the favourite version of Sard-Brown theorem. \square

5.12.1. Exhaustive sequences of compact submanifolds of non compact manifolds. The argument of Theorem 5.39 applies also to any boundaryless non compact submanifold $N \subset \mathbb{R}^h$ which is also a *closed subset* of \mathbb{R}^h . Then by using a generic δ_q , we can find a sequence of increasing regular values c_n , $c_n \rightarrow +\infty$, of the restriction of δ_q to N such that every

$$N_n := \{x \in N; \delta_q(x) \leq c_n\}$$

is a compact submanifold with boundary of N , $N_n \subset N_{n+1}$ and $\cup_n N_n = N$. That is we have an *exhaustive sequence of nested compact submanifolds with boundary*

of N . Every compact subset of N is contained in some N_n . In particular, If $f : M \rightarrow N$ is a \mathcal{C}^r or a \mathcal{E} -map, M being compact, then there is n such that $f(M) \subset N_n$ and we can extend the density result of $\mathcal{E}(M, N)$ in $\mathcal{C}^r(M, N)$. If all involved manifolds are Nash we have the density of $\mathcal{N}(M, N)$ in $\mathcal{E}(M, N)$ as well. We can also extend to N the notion of tubular neighbourhood. Fix a sequence a tubular neighbourhoods $\pi_n : U_n \rightarrow N_n$ constructed with respect to the standard metric g_0 on \mathbb{R}^h and a suitable decreasing sequence of $\epsilon_n > 0$. For every smooth positive function $\epsilon : N \rightarrow \mathbb{R}^+$ denote by $N_\epsilon := \{x \in \mathbb{R}^h; d(x, N) < \epsilon(x)\}$ that is the ϵ -neighbourhood of N with respect to the euclidean distance. Then we can find such a function ϵ such that for every $x \in N_n$, $\epsilon(x) < \epsilon_n$ so that the restriction of the projections π_n to N_ϵ match with the projection $\pi : N_\epsilon \rightarrow N$ such that $\pi(y) \in N$ is the nearest point to y on N .

5.13. Generic linear projections to hyperplanes

Let $M \subset \mathbb{R}^h$ be a compact boundaryless m -manifold as above. We have seen that generic linear projections of M to 1-dimensional subspaces of \mathbb{R}^h are Morse functions. Here we consider projections to hyperplanes, when the *codimension* $h - m$ is big enough. Precisely, let $\mathbb{R}^{h-1} \subset \mathbb{R}^{h-1} \times \mathbb{R}$; for every $v \in S^{h-1} \setminus \mathbb{R}^{h-1}$, let $p_v : \mathbb{R}^h = \mathbb{R}^{h-1} \oplus \text{span}(v) \rightarrow \mathbb{R}^{h-1}$ be the associated projection. We have

PROPOSITION 5.40. (1) *If $h > 2m$, then there is an open dense subset $I_M \subset S^{h-1}$ such that for every $v \in I_M$, the restriction of p_v to M is an immersion.*

(2) *If $h > 2m + 1$, then there is an open dense subset $E_M \subset S^{h-1}$ such that for every $v \in E_M$, the restriction of p_v to M is an embedding.*

Proof : (1) Let $UT(M) \subset M \times S^{h-1}$ the total space of the unitary tangent bundle of M (constructed by using the standard metric g_0 on \mathbb{R}^h). Let $t : UT(M) \rightarrow S^{h-1}$ the restriction of the projection $M \times S^{h-1} \rightarrow S^{h-1}$. Then the restriction of p_v to M fails to be an immersion if and only if v belongs to the image of t . $\dim UT(M) = 2m - 1 < h - 1$. Hence $S^{h-1} \setminus t(UT(M))$ is open and dense (by the easy case of Sard's theorem). This achieves point (1).

(2) The diagonal Δ is a closed subset of $M \times M$. Consider the smooth map defined on the complementary open set

$$\beta : M \times M \setminus \Delta \rightarrow S^{h-1}, \quad \beta(x, y) = \frac{x - y}{\|x - y\|}.$$

Then the restriction of p_v to M is not injective if and only if v or $-v$ belongs to the image of β . $\dim(M \times M \setminus \Delta) = 2m < h - 1$. Hence $S^{h-1} \setminus \text{Im}(\beta)$ is a dense subset. Its intersection with the dense open set $S^{h-1} \setminus t(UT(M))$ is also dense. Then we have a dense set of v 's such that the restriction of p_v is an injective immersion, hence an embedding of M because it is compact. Finally this set of v 's is also open because the set of embeddings is open. \square

The Morse projections to lines, and the above special cases of projections to hyperplane are the simplest instances of the general problem of understanding "generic" linear projections of compact embedded smooth manifolds to lower dimensional subspaces. An interested reader can look at the definetly more advanced paper [Ma].

5.13.1. Truncated classifying maps. The classification theorem 4.13, has been formulated in terms of the limit grassmannians $\mathfrak{G}_{\infty, k}$; however we know that every classifying map $f : M \rightarrow \mathfrak{G}_{\infty, k}$ factorizes through some $\hat{f} : M \rightarrow \mathfrak{G}_{n, k}$ (similarly for homotopies between maps defining strictly equivalent vector bundles), but a priori n might vary with M . In fact, arguing similarly to the weak immersion/embedding theorem, we show that there is a "uniform truncation" depending only on the dimension.

PROPOSITION 5.41. *Let M be a compact embedded m -manifold. (1) Then every $f : M \rightarrow \mathfrak{G}_{\infty,k}$ is homotopic to a map g which factorizes through a map $\hat{g} : M \rightarrow \mathfrak{G}_{m+k+1,k}$.*

(2) Two homotopic classifying maps with values in $\mathfrak{G}_{m+k+1,k}$ are homotopic via a homotopy which factorizes through a map in $\mathfrak{G}_{m+k+2,k}$.

Proof : Start with $\hat{f} : M \rightarrow \mathfrak{G}_{n,k}$, with $n > m + k + 1$. Hence the corresponding bundle is embedded into $M \times \mathbb{R}^n$. Consider linear projections $p_v : \mathbb{R}^n \rightarrow \mathbb{R}^{n-1}$, as above, and the maps

$$F_v : M \times \mathbb{R}^n \rightarrow M \times \mathbb{R}^{n-1}, (x, v) \rightarrow (x, p_v(v)) .$$

For a generic v , F_v embeds the vector bundle into $M \times \mathbb{R}^{n-1}$; this corresponds to a map $M \rightarrow \mathfrak{G}_{n-1,k}$ homotopic to the given one by the classification theorem. Similar considerations hold for homotopies.

□

The category of smooth manifolds

Abstract smooth manifolds and smooth maps between them will be introduced by taking as *definition* some properties verified by embedded ones. We will see in Section 6.7 that abstract compact manifolds can be embedded in some \mathbb{R}^n . As we are mainly interested in compact manifolds, considered up to diffeomorphism, this abstraction would appear to be a bit superfluous. However there are some good reasons to proceed. There are natural constructions (quotients, “cut-and-paste”, . . . , we will see them) to build new *abstract* manifolds, starting from given ones (even embedded, even staying in the realm of compact manifolds). It would be artificial to force them to deal from the beginning in the embedded setting. It is more convenient to use the embedding result *ex post*, in order to exploit the facts already established for compact embedded manifolds.

DEFINITION 6.1. A topological space M is a *m-smooth manifold* (we will omit the adjective “abstract”) if:

- M is Hausdorff and with a countable basis of open sets.
- M admits an *smooth atlas* $\mathcal{U} = \{W_j, \phi_j\}_{j \in J}$ (J being any set of indices); that is
 - (i) $\{W_j\}_{j \in J}$ is an open covering of M ;
 - (ii) every *chart* $\phi_j : W_j \rightarrow U_j \subset \mathbb{R}^m$ is a *homeomorphism* onto a open set of \mathbb{R}^m (denote by $\psi_j : U_j \rightarrow W_j$ the inverse *local parametrization*);
 - (iii) for every $i, j \in J$,

$$\phi_j \circ \psi_i : \phi_i(W_i \cap W_j) \rightarrow \phi_j(W_i \cap W_j)$$

is a smooth *diffeomorphism*.

We summarize this item by saying that M is (smoothly) *locally m-euclidean*.

REMARKS 6.2. (1) Every smooth atlas \mathcal{U} of M is contained in and implicitly determines a unique maximal smooth atlas $\mathcal{A} = \mathcal{A}_M$; this is identified with a specific *smooth structure on M* . In the embedded case $M \subset \mathbb{R}^n$, the charts of \mathcal{A} were smooth by themselves, referring to the smooth structure of the ambient euclidean space. In the abstract case every single chart is only a homeomorphism; the smooth structure is entirely carried by the changes of local coordinates. Nevertheless, this is enough to deduce for example that the *dimension m* is well defined, alike the embedded case.

(2) Obviously every embedded smooth manifold is a smooth manifold.

(3) Being locally euclidean does not imply any of the global topological requirements of the first item. For example consider $M = \mathbb{R}^m \times (\mathbb{R}, \tau_d)$ where the second factor is endowed with the *discrete topology*. Then M is Hausdorff and locally m -euclidean, but it has no countable basis of open sets. On another hand, consider on $\mathbb{R} \times \{0, 1\}$ (with the product topology) the equivalence relation such that $(x, j) \sim (y, i)$ if and only if either $(x, j) = (y, i)$ or $x = y$ and $x > 0$. Let M be the quotient topological space. Then M is 1-locally euclidean and has a countable basis of open sets, but it is not Hausdorff. In fact the two points $[(0, 0)] \neq [(0, 1)] \in M$

cannot be separated by disjoint neighbourhoods. $M \times \mathbb{R}^k$ presents the same phenomenon in arbitrary dimension.

(4) The fact that “locally euclidean” does not imply Hausdorff poses some principle question when one uses manifolds as model of some physical space or space-time. Local observations can support the idea that phenomena live in a locally euclidean environment, but it is much more arbitrary to assume also the (global) separation property. For example in some models of space-time one does not assume a priori that it is Hausdorff, and this property is derived a posteriori as consequence of certain global “causality assumptions” which look founded on some reasonable physical (or philosophical) considerations [HE]. To our aims, we do not hesitate to make these topological assumptions; as the theory is already rich, there are no reasons to renounce say the limit uniqueness or the equivalence between compact and sequentially compact spaces.

DEFINITION 6.3. Let $f : M \rightarrow N$ be a continuous map between smooth manifolds of dimension m and n respectively. A *representation in local coordinates* of f is of the form

$$\hat{f} = \phi' \circ f \circ \psi : U \rightarrow U'$$

where $\phi : W \rightarrow U \subset \mathbb{R}^m$ is a chart of \mathcal{A}_M , $\phi' : W' \rightarrow U' \subset \mathbb{R}^n$ is a chart of \mathcal{A}_N , $f(W) \subset W'$. Then f is *smooth* if for every $p \in M$ there is a local representation of f such that $p \in W$ and \hat{f} is a smooth map between open sets of euclidean spaces. The map f is a *diffeomorphism* if it is a homeomorphism and both f and f^{-1} are smooth.

The following Lemma is an easy consequence of the definitions and of the basic fact that the composition of smooth maps between open sets of euclidean spaces is smooth (details are left as an exercise).

LEMMA 6.4. *If $f : M \rightarrow N$ is a smooth maps between smooth manifolds, then every local representation of f in local coordinates is smooth.*

□

Obviously smooth maps and diffeomorphisms between embedded manifolds fulfill the above definition. So we have introduced the *category of smooth manifolds and smooth maps (diffeomorphisms)* which extends the embedded one.

Let us describe some constructions that naturally produce (abstract) smooth manifolds.

(1) (*Quotient manifolds*) Let \tilde{M} be a smooth manifold (even embedded). Let G be a subgroup of the group $\text{Aut}(\tilde{M})$ of smooth automorphisms of \tilde{M} . Assume that G acts *freely* and *properly discontinuously* on \tilde{M} . This means that for every $p \in \tilde{M}$, the identity is the only element of G that fixes p , and that for every compact subset K of \tilde{M} , the set of $g \in G$ such that $K \cap g(K) \neq \emptyset$ is *finite*. Let $M := \tilde{M}/G$ be the quotient topological space. It is known that M is Hausdorff and with countable basis. Moreover, the projection $\pi : \tilde{M} \rightarrow M$ is a covering map. We can assume that for every $p \in M$, there is a open connected neighbourhood W of p such that the restriction of π to every connected component \tilde{W} of $\pi^{-1}(W)$ is a homeomorphism, and (\tilde{W}, ϕ) belongs to $\mathcal{A}_{\tilde{M}}$. Then by varying p in M , $\{(W, \phi \circ \pi^{-1})\}$ is a smooth atlas of M , such that π becomes a smooth, locally diffeomorphic map.

(2) (*Grassmann manifolds again*) We have already defined the projective spaces $\mathbf{P}^k(\mathbb{R})$ as special instances of (embedded) grassmann manifolds. There is another classical way to obtain it. Consider \mathbb{R}^{k+1} . The multiplicative group \mathbb{R}^* acts on \mathbb{R}^{k+1} . Consider the quotient topological space $\mathbb{R}^{k+1}/\mathbb{R}^*$. This is not Hausdorff; the only saturated open set of \mathbb{R}^{k+1} containing 0 is the whole of \mathbb{R}^{k+1} and this intersects any other saturated open set. If we remove 0, and we restrict the action of \mathbb{R}^*

things go better. Evidently the orbits, i.e. the equivalence classes are in bijective correspondence with the set of 1-dimensional linear subspaces of \mathbb{R}^{k+1} . Then one easily verifies that the quotient topological space $\mathbf{P}^k(\mathbb{R}) := (\mathbb{R}^{k+1} \setminus \{0\})/\mathbb{R}^*$ is now Hausdorff and with countable basis. We see also that we get the same quotient space if we restrict the equivalence relation to the unit sphere S^k , and that the restriction of the projection onto the quotient, $\pi : S^k \rightarrow \mathbf{P}^k(\mathbb{R})$ is a 2 : 1 local *homeomorphism*. In fact it is the quotient map by the action on S^k of the group G of order 2 generated by the antipodal map $x \rightarrow -x$. Then we can endow $\mathbf{P}^k(\mathbb{R})$ with a smooth manifold structure as a particular case of point (1). We can do it also without restricting to S^k . A finite atlas of $\mathbf{P}^k(\mathbb{R})$ is formed by $\{(W_j, \phi_j)\}_{j=1, \dots, k+1}$, where W_j is the image of the saturated open set $\{x_j \neq 0\}$ of $\mathbb{R}^{k+1} \setminus \{0\}$;

$$\phi_j([x_1, \dots, x_{k+1}]) = (x_1/x_j, \dots, x_{j-1}/x_j, x_{j+1}/x_j, \dots, x_{k+1}/x_j)$$

is a homeomorphism of W_j onto \mathbb{R}^k . It is immediate to check that the changes of local coordinates are smooth (actually rational). A posteriori we can define, in a natural way, a diffeomorphism of this abstract model of the projective space to the embedded model already constructed.

Every grassmann manifold could be treated in a similar way. First define it as the quotient topological space of the associated linear Stiefel manifold (which is a open set in some euclidean space). Prove that this quotient is Hausdorff and with countable basis and finally give it a (abstract) smooth atlas made by the image of suitable saturated open sets of the Stiefel manifold. A posteriori one can construct a diffeomorphism onto the already constructed embedded model.

EXAMPLE 6.5. Let us make a few examples. We are going to establish that $SO(3) \sim \mathbf{P}^3(\mathbb{R})$. An elegant way to see it is by using *quaternions*. Let \mathbf{H} be the *quaternion* algebra in its matrix form. That is \mathbf{H} is the subalgebra of the matrix algebra $M(2, \mathbb{C})$ of the matrices of the form

$$A = \begin{pmatrix} a + ib & c + id \\ -c + id & a - ib \end{pmatrix}$$

where $a, b, c, d \in \mathbb{R}$. Then \mathbf{H} is generated by the matrix

$$A(i) = \begin{pmatrix} i & 0 \\ 0 & -i \end{pmatrix}, \quad A(j) = \begin{pmatrix} 0 & 1 \\ -1 & 0 \end{pmatrix}, \quad A(k) = \begin{pmatrix} 0 & i \\ i & 0 \end{pmatrix}$$

which verifies the relations

$$\begin{aligned} A(i)^2 &= A(j)^2 = A(k)^2 = -I \\ A(i)A(j) &= A(k) = -A(j)A(i), \quad A(j)A(k) = A(i) = -A(k)A(j) \\ A(k)A(i) &= A(j) = -A(j)A(k) . \end{aligned}$$

By setting

$$A^* := \bar{A}^t$$

we have

$$\begin{aligned} (AB)^* &= A^* + B^*, \quad (AB)^* = A^*B^* \\ |A|^2 &:= AA^* = \det A \end{aligned}$$

and if $A \neq 0$

$$A^{-1} = \frac{1}{|A|^2} A^* .$$

Set

$$\mathbf{H}_1 = \{A \in \mathbf{H}; |A| = 1\} .$$

This is a group with respect to the restriction of the multiplication. In fact \mathbf{H}_1 is naturally identified with the special unitary group $SU(2)$ which as a manifold is naturally identified with the unit sphere S^3 in \mathbb{R}^4 . Set

$$\mathbf{H}_0 = \{A \in \mathbf{H}; A^* = -A\} .$$

which is naturally identified with an euclidean space \mathbb{R}^3 . One verifies easily that for every $A \in \mathbf{H}_1$,

$$\alpha_A : \mathbf{H}_0 \rightarrow \mathbf{H}_0, X \rightarrow AXA^{-1}$$

acts as a rotation on $\mathbf{H}_0 = \mathbb{R}^3$. In fact this gives us a degree 2 covering map

$$SU(2) \rightarrow SO(3), A \rightarrow \alpha_A$$

such that $\alpha_A = \alpha_B$ if and only if $B = \pm A$. Hence finally

$$SO(3) \sim SU(2)_{/\pm I} \sim \mathbf{P}^3(\mathbb{R})$$

as claimed.

Let us consider now for every $(P, Q) \in SU(2) \times SU(2) = \mathbf{H}_1 \times \mathbf{H}_1$, the map

$$\alpha_{P,Q} : \mathbf{H} \rightarrow \mathbf{H}, A \rightarrow PAQ^{-1}$$

by identifying $\mathbf{H} \sim \mathbb{R}^4$, $\alpha_{P,Q} \in SO(4)$ and $\alpha_{P,Q} = \alpha_{P',Q'}$ if and only if $(P, Q) = \pm(P', Q')$. Then similarly as above we get that

$$(SU(2) \times SU(2))_{/\pm 1} \sim SO(4).$$

(3) (*Grassmann manifolds of oriented spaces*) The set $\tilde{\mathcal{G}}_{m,n}$ of oriented n -subspaces of \mathbb{R}^m can be naturally endowed with a smooth compact manifold structure $\tilde{\mathfrak{G}}_{m,n}$ such that the map

$$p : \tilde{\mathcal{G}}_{m,n} \rightarrow \mathcal{G}_{m,n}$$

that forgets the orientation becomes a degree 2 smooth covering map

$$p : \tilde{\mathfrak{G}}_{m,n} \rightarrow \mathfrak{G}_{m,n}.$$

There is a natural tautological bundle

$$\tilde{\tau} : \mathcal{V}(\tilde{\mathfrak{G}}_{m,n}) \rightarrow \tilde{\mathfrak{G}}_{m,n}$$

which in fact equals $p^*(\tau)$. The fibres of $\tilde{\tau}$ are tautologically oriented and this is also the case for every pull-back of $\tilde{\tau}$.

(4) This example could sound a bit artificial, but it reveals nevertheless some subtilities. let M be a smooth manifolds (even embedded). Let $f : X \rightarrow M$ be any *homeomorphism*. Then

$$\mathcal{U}_f := \{(f^{-1}(W), \phi \circ f)\}_{(W, \phi) \in \mathcal{A}_M}$$

is a *smooth atlas* on X so that f becomes tautologically a diffeomorphism. If $X = M$ (as a topological space), the two smooth structures given by \mathcal{U}_f and \mathcal{A}_M are diffeomorphic to each other but they are not the same structure (in other words id_M is *not* a diffeomorphism). Even if M is embedded in no natural way the structure given by \mathcal{U}_f is embedded.

Let us retrace and extend a few notions already developed for embedded manifolds. The operative principle is:

Whatever has been built in terms of smooth atlas can be done as well for abstract smooth manifolds.

Manifolds with boundary. We extend the Definition 6.1 by admitting smooth atlas with charts homeomorphic to open sets of the half space \mathbf{H}^m . The boundary ∂M is (well) defined by the same arguments of the embedded case.

Orientable/oriented manifolds as well as the **oriented boundary** of an oriented manifold with boundary treated in terms of **oriented atlas** make sense verbatim also in the abstract case. Also the interpretation in terms of the determinant bundle will extend as soon as it shall be defined (see below).

Boundaryless **submanifolds** of a boundaryless manifold are defined in terms of the existence of atlas made by relatively normal charts. Relatively normal charts are

defined also at the boundary of a manifold with boundary. As for embedded manifolds, especially if both the manifold and a submanifold have non empty boundary, there are many possible configurations. Also in the abstract case, one points out the notion of **proper submanifold** (we will return on and use it diffusely later).

Smooth fibred bundles and related notions introduced in Section 2.6 extend words by words by replacing embedded with arbitrary smooth manifolds and maps.

By using the basis of neighbourhoods defined in terms of representations of maps in local coordinates (as in (2) of Section 2.4), then the definition of the **function spaces** $\mathcal{E}^r(M, N)$, $\mathcal{E}(M, N)$ extends without any change to the abstract case.

Homotopy, isotopy, diffeotopy and the **homogeneity** property (see Section 2.5) extend as well.

6.1. The (abstract) tangent functor

Probably this is the most demanding extension by dealing with abstract smooth manifolds. In the case of embedded manifolds tangent bundles and maps imposed by themselves, starting from the basic ones for open sets in some euclidean spaces. In the abstract case they must be somehow “invented”, with the constraint to agree with already done in the embedded category. This also will bring us to a general notion of *fibre bundle in the sense of Steenrod* [Steen].

Construction of the tangent bundle. Let M be a m -smooth manifold with its maximal smooth atlas $\mathcal{A} = \{(W_j, \phi_j)\}_{j \in J}$. For every $(i, j) \in J^2$, define the map

$$\mu_{ji} : W_i \cap W_j \rightarrow \text{GL}(m, \mathbb{R}), \quad \mu_{ji}(x) = d_{\phi_i(x)}(\phi_j \circ \phi_i^{-1}) .$$

This family of maps $\{\mu_{ji}\}_{(i,j) \in J^2}$ verifies the following properties:

- (1) Every μ_{ji} is smooth.
- (2) For every $j \in J$, for every $x \in W_j \cap W_j = W_j$,

$$\mu_{jj}(x) = I_m .$$

- (3) For every $(j, i) \in J^2$, for every $x \in W_i \cap W_j = W_j \cap W_i$,

$$\mu_{ji}(x) = \mu_{ij}(x)^{-1} .$$

- (4) For every $(i, j, k) \in J^3$, for every $x \in W_i \cap W_j \cap W_k$

$$\mu_{ik}(x)\mu_{kj}(x)\mu_{ji}(x) = I_m .$$

We summarize these properties by saying that

$\{\mu_{j,i}\}$ is a smooth cocycle on the open covering \mathcal{A} with values in the Lie group $\text{GL}(m, \mathbb{R})$.

Note that as $\text{GL}(m, \mathbb{R})$ is *non commutative* (if $m > 1$), then the order in property 4 is not negligible.

Let us consider now the topological product $M \times \mathbb{R}^m \times J$, where J is endowed with the discrete topology. Let \mathcal{T} be the subspace made by the triples (x, v, j) such that $x \in W_j$. Hence \mathcal{T} is the *disjoint* union of the open sets $W_j \times \mathbb{R}^m \times \{j\}$, $j \in J$, each one being canonically homeomorphic to $W_j \times \mathbb{R}^m$. Now let us put on \mathcal{T} the relation $(x, v, j) \sim (x', v', k)$ if and only if $x = x'$ and $v' = \mu_{kj}(x)v$. The cocycle properties 2–4 ensure that it is an equivalence relation. We set

$$T(M) := \mathcal{T} / \sim$$

the topological quotient space and denote by $q : \mathcal{T} \rightarrow T(M)$ the canonical continuous projection. We have the well defined surjective map

$$\pi_M : T(M) \rightarrow M, \quad \pi_M([x, v, j]) = x$$

which is continuous. In fact for every open set A of M , $(\pi_M \circ q)^{-1}(A)$ is the intersection of \mathcal{T} with $A \times \mathbb{R}^m \times J$, hence it is a saturated open set, with open image

in $T(M)$. It is a topological exercise to show that $T(M)$ is Hausdorff and with countable basis, this is left to the reader.

(Local trivializations) For every $j \in J$, set

$$\Psi_j : W_j \times \mathbb{R}^m \rightarrow T(M), (x, v) \rightarrow q(x, v, j) = [(x, v, j)].$$

One verifies that

- (1) Ψ_j is continuous (because q is continuous);
- (2) Ψ_j takes values in $\pi_M^{-1}(W_j)$ and $\pi_M \circ \Psi_j = p_j$, where $p_j : W_j \times \mathbb{R}^m \rightarrow W_j$ is the projection.
- (3) In fact Ψ_j is a homeomorphism onto $\pi_M^{-1}(W_j)$. For if $b = [x, v, k] \in \pi_M^{-1}(W_j)$, then $b = \Psi_j(x, \mu_{jk}(x)v)$, hence Ψ_j is onto. If $[x, v, j] = [x', v', j]$, then $x = x'$ and $v = v'$ because $\mu_{jj} = I_m$. Hence Ψ_j is injective. Finally, to show that the inverse of Ψ_j is continuous, it is enough to show that if A is open in $W_j \times \mathbb{R}^m$, the $q^{-1}(\Psi_j(A))$ is open in \mathcal{T} . Since the $W_k \times \mathbb{R}^m \times \{k\}$'s form an open covering of \mathcal{T} , it is enough to prove that every $q^{-1}(\Psi_j(A)) \cap (W_k \times \mathbb{R}^m \times \{k\})$ is open. This intersection is contained in the open set $(W_j \cap W_k) \times \mathbb{R}^m \times \{k\}$ of \mathcal{T} . On this open set $q = \Psi_j \circ r$, where $r(x, v, k) = (x, \mu_{jk}(x)v)$ which is continuous; the thesis follows.

(Changes of local trivializations) These are of the form

$$\Psi_j^{-1} \circ \Psi_i(x, v) = (x, \mu_{ji}(x)v)$$

defined on $(W_j \cap W_i) \times \mathbb{R}^m$ to itself. Clearly they are smooth, and pointwise linear in the second argument. So we have proved that

$$\pi_M : T(M) \rightarrow M$$

is a (abstract) smooth vector bundle over M with fibre \mathbb{R}^m , called the *tangent bundle of M* . For every $p \in M$, the fibre $T_p M := \pi_M^{-1}(p)$ is *by definition* the *tangent space of M at p* . It is clear that $T(M)$ is a smooth manifold because it is locally diffeomorphic to spaces of the form $W_j \times \mathbb{R}^m$, W_j being an open set in the smooth manifold M . To be even more concrete, we can exhibit the following special smooth atlas of $T(M)$ made of fibred maps:

$$T\mathcal{A} = \{\pi_M^{-1}(W_j), \Phi_j\}_{j \in J}$$

where $\Phi_j := (\phi_j, \text{id}) \circ \Psi_j^{-1}$, and

$$(\phi_j, \text{id}) : W_j \times \mathbb{R}^m \rightarrow U_j \times \mathbb{R}^m \subset \mathbb{R}^m \times \mathbb{R}^m, (x, v) \rightarrow (\phi_j(x), v).$$

The changes of local coordinates are of the form

$$\Phi_j \circ \Phi_i^{-1}(x, v) = (\phi_j \circ \phi_i^{-1}(x), \mu_{ji}(x)v)$$

which *ultimately is nothing else than the tangent maps of the change of coordinates on M* .

Tangent maps. Let $f : M \rightarrow M'$ be a smooth map between smooth manifolds. We want to define now the tangent map

$$Tf : T(M) \rightarrow T(M')$$

in such a way that $[f, Tf]$ is a vector bundle fibred map. We have constructed the tangent bundles by patching together the product pieces. We do similarly for Tf . Precisely, let $(\pi_M^{-1}(W), \Phi)$, $(\pi_{M'}^{-1}(W'), \Phi')$ be fibred charts of $T(M)$ and $T(M')$ which dominate charts (W, ϕ) , (W', ϕ') of M and M' respectively. Assume also that this system of charts gives us a representation in local coordinates of f , $\hat{f} = \phi' \circ f \circ \phi^{-1}$. Then we *locally* define

$$Tf_{W, W'} : \pi_M^{-1}(W) \rightarrow \pi_{M'}^{-1}(W'), Tf_{W, W'} = \Phi' \circ T\hat{f} \circ \Phi^{-1}.$$

Recalling the equivalence relation that we have used to build the tangent bundles, one readily checks that these locally defined Tf 's are in fact *representations in local*

(fibred) coordinates of a **globally** defined fibred map $Tf : T(M) \rightarrow T(M')$. For every $p \in M$ the restriction say $d_p f$ of Tf to $T_p M$, is a linear map

$$d_p f : T_p M \rightarrow T_{f(p)} M'$$

which by definition is the *differential of f at p* .

Tangent functor. The basic functorial properties of the chain rule globalize, so that we have:

The tangent category of the category of smooth manifolds has as objects the tangent vector bundles of smooth manifolds and as morphisms the tangent maps of smooth maps between embedded manifolds. This is a subcategory of smooth vector bundles over smooth manifolds. Then

$$M \Rightarrow \pi_M : T(M) \rightarrow M, f : M \rightarrow M' \Rightarrow [f, Tf]$$

define a covariant functor from the category of embedded smooth manifolds to its tangent category. This extends the embedded tangent functor.

Immersion and embeddings. As we dispose now of the differentials $d_p f$ for every smooth map, the notions of immersion and embedding extend as well as the related results of section 2.3.

6.2. Principal and associated bundles with given structural group

The construction of the tangent bundles is suited to a wide generalization.

Let G be a Lie group (such as $GL(m, \mathbb{R})$, $O(m)$, $SO(n)$, $U(n)$, ...). Assume that it acts on a smooth manifold F . This means that there is a group homomorphism (also called a *representation*)

$$\rho : G \rightarrow \text{Aut}(F) ;$$

the associate action is

$$G \times F \rightarrow F, (g, x) \rightarrow \rho(g)(x)$$

and sometimes one simply writes gx instead of $\rho(g)(x)$. Sometimes one also requires that ρ is injective so that G is confused with its image in $\text{Aut}(F)$ and considered as a *group of transformations of F* (but this is not strictly necessary).

REMARK 6.6. G acts on itself by the injective homomorphism $g \rightarrow L_g$ (i.e. by left multiplication)

$$G \times G \rightarrow G, (g, h) \rightarrow L_g(h) := gh .$$

Let M be a smooth manifold and $\mathcal{U} = \{A_s\}_{s \in \mathcal{I}}$ be an open covering of M . A *principal cocycle* on \mathcal{U} with values in the *structural group* G is a family of smooth maps

$$\mathbf{c} = \{c_{ts} : A_s \cap A_t \rightarrow G\}_{(s,t) \in \mathcal{I}^2}$$

such that

- (1) For every $s \in \mathcal{I}$, for every $x \in A_s$,

$$c_{ss}(x) = 1 \in G .$$

- (2) For every $(s, t) \in \mathcal{I}^2$, for every $x \in A_s \cap A_t$,

$$c_{st}(x) = c_{ts}(x)^{-1} .$$

- (3) For every $(s, t, r) \in \mathcal{I}^3$, for every $x \in A_s \cap A_t \cap A_r$

$$c_{sr}(x)c_{rt}(x)c_{ts}(x) = 1 .$$

For every representation $\rho : G \rightarrow \text{Aut}(F)$ as above, we have an *associated cocycle* with values in $\text{Aut}(F)$

$$\{\rho_{ts} := \rho \circ c_{ts} : A_s \cap A_t \rightarrow \text{Aut}(F)\}_{(s,t) \in \mathcal{I}^2}$$

which verifies the same properties 1-3 (by replacing $1 \in G$ with $1 \in \text{Aut}(F)$).

Then we can repeat words by words the above construction of the tangent bundles and get a *smooth fibres bundle over M with structural group G and fibre F* . So we have a wide family of bundles which share the basic cocycle \mathbf{c} . When $F = G$ and G acts as above by left multiplication, we get the *principal bundle* of this family; all the other bundles are said *associated* to such a principal bundle.

6.2.1. Equivalent cocycles. The strict equivalence of fibre bundles can be rephrased in terms of the defining cocycles. Assume that two cocycles c and c' with values in G are defined on the same open covering $\mathcal{U} = \{A_s\}_{s \in \mathcal{I}}$ of M . Then they define strictly equivalent bundles if and only if there is a family of maps

$$\{\lambda_s : A_s \rightarrow G\}_{s \in \mathcal{I}}$$

such that for every (s, t) , for every $x \in A_s \cap A_t$,

$$c'_{ts}(x) = \lambda_s(x)c_{ts}(x)\lambda_t(x)^{-1} .$$

6.2.2. Tensor bundles. We can apply this machinery to construct the abstract version of the tensor bundle relatives to the tangent bundle.

In Section 2.7, for every (p, q) , we have defined the representation

$$\rho_{p,q} : \text{GL}(m, \mathbb{R}) \rightarrow \text{GL}(T_q^p(\mathbb{R}^m)) \sim \text{GL}(m^{pq}, \mathbb{R})$$

which is an explicit rational regular map. By using it we get the tensor bundle

$$\pi_{p,q} : T_q^p(M) \rightarrow M .$$

The representation

$$\det : \text{GL}(m, \mathbb{R}) \rightarrow \mathbb{R}^*$$

leads to the *determinant bundle* of M

The principal bundle of this family is the *frame bundle* of M , once we have identified the columns of any non singular matrix with a basis of \mathbb{R}^m .

Tensors fields. The contents of Sections 2.8 and 2.9 extend verbatim.

6.3. Embedding abstract compact manifolds

Let M be a compact smooth m -manifold possibly with boundary ∂M . The notion of nice atlas makes sense in full generality. We have:

PROPOSITION 6.7. (1) *Let M be a compact smooth manifold. Then there is a diffeomorphism $f : M \rightarrow M'$ onto an embedded manifold $M' \subset \mathbb{R}^h$, for some h .*

(2) *The tangent map Tf establishes a vector bundle equivalence between the respective tangent bundles of M and M' . This equivalence propagates to all tensor bundles and to the frame bundle.*

Proof : (1): we argue as in the proof of Proposition 5.12, by using a nice atlas of M $\{(W_j, \phi_j)\}_{j=1, \dots, s}$ including also relative normal charts along ∂M , instead of a nice atlas with collar. This allows to define the embedding

$$\beta = (\beta_1, \dots, \beta_s) : M \rightarrow (\mathbb{R}^m \times \mathbb{R})^s$$

$$\beta_j = (\lambda_j \phi_j, \lambda_j) .$$

The verification is the same of Proposition 5.12.

Point (2) follows from the fact that the abstract functor extends the embedded one.

□

By combining the last proposition with Proposition 5.40 we have:

COROLLARY 6.8. (Weak Whitney immersion/embedding theorem) *Every m -dimensional compact smooth m -manifold M can be immersed in \mathbb{R}^{2m} and can be embedded in \mathbb{R}^{2m+1} .*

Proof : If M is boundaryless it is an immediate corollary of Propositions 6.7 and 5.40. If M has boundary we can reduce to the boundaryless case by using the double of M . □

So, up to diffeomorphism we can assume that every compact manifold M is embedded. We extend now this result to every abstract vector bundle over M , besides the tangent and tensor bundles.

PROPOSITION 6.9. *Every abstract vector bundle ξ over an embedded compact smooth manifold $M \subset \mathbb{R}^h$ is strictly equivalent to an embedded vector bundle.*

Proof : By compactness we can assume that the abstract bundle $p : E \rightarrow M$ is determined by a cocycle c_{ts} over a nice atlas $\mathcal{U} = \{(W_j, \phi_j)\}_{j=1, \dots, s}$ of M . Consider the family of local trivializations $\Phi_j : p^{-1}|W_j \rightarrow W_j \times \mathbb{R}^n$, and let $\{\lambda_j\}$ be the partition of unity over \mathcal{U} as usual. For every j , denote by $q_j : W_j \times \mathbb{R}^n \rightarrow \mathbb{R}^n$ the natural projection. Finally define

$$h : E \rightarrow M \times \mathbb{R}^{ns} \subset \mathbb{R}^{h+ns}, \quad h(e) = (p(e), \lambda_1(p(e))q_1(e), \dots, \lambda_s(p(e))q_s(e)).$$

The restriction of h to $M \subset E$ as the zero section is equal to the identity. Moreover every fibre of the bundle is linearly embedded onto a n -subspace of \mathbb{R}^{ns} . □

REMARK 6.10. (1) The conclusion of Proposition 6.9 holds as well for the frame bundle and more generally for any abstract smooth fibre bundle over M with embedded fibre.

6.3.1. On vector bundles on sphere again. Now we can complete the classification of vector bundles on the spheres stated in Section 5.7. By combining those constructions with the present ones, every map $\rho_\xi : S^{m-1} \rightarrow \text{GL}^+(k, \mathbb{R})$ extends to a cocycle $\rho_\xi : D^+ \cap D^- \rightarrow \text{GL}^+(k, \mathbb{R})$ on the nice covering of the sphere formed by the two smooth disks D^+, D^- . So the claimed inverse map ρ^{-1} is obtained by taking the strict equivalence class of the embedded vector bundle over S^{m-1} constructed as in Proposition 6.9 by using this cocycle.

6.3.2. On tubular neighbourhoods and collars again. In Section 5.3 we have constructed tubular neighbourhoods and collars *unique up to isotopy* starting from an *embedded* compact manifold $M \subset \mathbb{R}^k$. Above we have shown that every (abstract) compact manifold M can be embedded in some \mathbb{R}^k and, *a priori*, that family of tubular neighbourhoods and collars, considered up to isotopy, could depend on the embedding. However this is not the case. First every embedding $M \subset \mathbb{R}^k$ can be “stabilized” to $M \subset \mathbb{R}^k \subset \mathbb{R}^{k+h}$; moreover, by using the results of the present section with Proposition 5.40, if h is big enough, up to isotopy two embeddings of M in \mathbb{R}^{k+h} have disjoint images and can be extended to an embedding of $M \times [0, 1]$ so that they are isotopic to each other.

Summarizing:

By considering compact smooth manifolds up to diffeomorphism, we can exploit all the results already obtained in Chapter 5 for embedded compact manifolds.

6.4. On complex manifolds

Another reason to introduce the abstract notion of manifold in terms of atlas with change of coordinates in a determined class of homeomorphism (for instance smooth diffeomorphisms in our favourite setting) is that it is suited to several interesting implementations. Abstract *complex n -manifolds* have as local models the open sets in \mathbb{C}^n and change of coordinates that are complex analytic (i.e. holomorphic) diffeomorphisms (biholomorphisms). Holomorphic maps between complex manifolds are defined in terms of holomorphic local representations; and so on, by following and specializing several constructions developed above (complex tangent bundle, complex submanifolds etc.). On the other hand, by the *maximum principle*, the constant functions $c : M \rightarrow \mathbb{C}$ are the only holomorphic functions defined on any compact connected complex manifold M . So compact complex manifolds *cannot be embedded into any \mathbb{C}^m* (as complex submanifolds). This is a main difference with respect to our favourite real smooth theory. Moreover, bump functions do not exist in the complex setting, so the many constructions which have employed such a tool cannot be performed on complex manifolds. Although we have introduced them as examples of embedded smooth manifolds, *complex Stiefel and Grassmann manifolds* (in particular the complex projective spaces) can be naturally endowed with an (abstract) structure of compact complex manifold.

By identifying $\mathbb{C}^n \sim \mathbb{R}^{2n}$ and considering holomorphic maps as a special kind of smooth maps, by forgetting the complex structure, every complex n -manifolds M can be considered as a smooth $2n$ -manifold (as we have done for the complex Grassmannian); moreover the complex structure induces on this $2n$ -manifold a *natural orientation*. Especially in dimension 4, 2-complex manifolds (also called *complex surfaces*) form an important class of oriented 4-manifolds.

(The Riemann sphere) As a basic example let us consider $\mathbf{P}^1(\mathbb{C})$; let us identify $\mathbb{R}^2 \sim \mathbb{C}$ and consider the two-charts atlas of the 2-sphere S^2 given by the stereographic projections from the two poles. These can be considered as \mathbb{C} -valued charts. In order to make it a complex-manifold atlas it is enough to compose the second projection with the complex conjugation $z \rightarrow \bar{z}$. Moreover it is immediate to identify such an atlas with the standard two-charts complex atlas of $\mathbf{P}^1(\mathbb{C})$. This show in particular that $\mathbf{P}^1(\mathbb{C})$ is diffeomorphic to S^2 ; this last considered as a 1-dimensional complex manifold is called the *Riemann sphere*.

Cut and paste compact manifolds

In this Chapter we deal with compact manifolds or more generally with possibly non compact manifolds which nevertheless can be embedded in some \mathbb{R}^n being a closed subset too. Thus we can exploit the results of Chapter 5.

7.1. Extension of isotopies to diffeotopies

We recall a few notions.

Let N be a smooth boundaryless n -manifold. Let M be a smooth m -manifold and

$$F : M \times [0, 1] \rightarrow N$$

a smooth map such that f_t is an embedding for every $t \in [0, 1]$; then F is an *isotopy* connecting f_0 and f_1 .

A *diffeotopy* of N (also called an *ambient isotopy*) is a smooth map

$$G : N \times [0, 1] \rightarrow N$$

such that g_t is a diffeomorphism for every $t \in [0, 1]$. We will also assume that $g_0 = \text{id}_N$. Hence diffeotopies are special isotopies.

DEFINITION 7.1. We say that an isotopy F as above *extends to an ambient isotopy* if there is a diffeotopy G of N such that $f_t = g_t \circ f_0$ for every $t \in [0, 1]$. Note that $\{V_t = f_t(M)\}$ is a one parameter family of submanifolds of N (each diffeomorphic to M), and $V_t = g_t(V_0)$, for every t .

We are going to see that under mild compactness assumptions, isotopies actually extend to diffeotopies. This will be a key result to show that several cut-and-paste procedures below are well defined. To this aim, it is useful to recast diffeotopies as flow of (suitable) vector fields. In doing it we will tacitly incorporate basic facts about the existence, uniqueness and regular dependence on the initial data of the solutions of *ordinary differential equations* (see for instance [A]).

For every isotopy F as above, its *track* is the map defined as

$$\hat{F} : M \times [0, 1] \rightarrow N \times [0, 1], \quad \hat{F}(x, t) := (f_t(x), t) .$$

The *support* of F is the closure in M of the set

$$\{x \in M \mid \exists t \in [0, 1], f_t(x) \neq f_0(x)\} .$$

Given an ambient isotopy G of N , as above, and its track \hat{G} (which is a level preserving diffeomorphism), consider on $N \times [0, 1]$ the constant “vertical” tangent vector field V defined by

$$V(x, t) = (0, 1) \in T_x N \times \mathbb{R} .$$

The tangent map $T\hat{G}$ transforms this field into another tangent vector field on $N \times [0, 1]$ of the form

$$X_G(x, t) = (v_G(x, t), 1) .$$

Then the map \hat{G} transforms every vertical integral line $j_x : [0, 1] \rightarrow N \times [0, 1]$ of V such that $j_x(0) = (x, 0)$, into the integral line $\hat{j}_x : [0, 1] \rightarrow N \times [0, 1]$ of the field X_G such that $\hat{j}_x(0) = (x, 0)$. In fact, by construction

$$\hat{G}(j_x(t)) = \hat{j}_x(t) = (g_t(x), t)$$

that is G is the *flow* of X_G , with initial data at $N \times \{0\}$. Hence we can reconstruct the diffeotopy G by integration of the field X_G .

On the other hand, if $v(x, t)$, $t \in [0, 1]$, is any *time depending smooth tangent vector field on N* , let $X(x, t) = (v(x, t), 1)$ be the corresponding field on $N \times [0, 1]$. Let us say that it has *complete integral lines* if for every initial point $(x, 0) \in N \times [0, 1]$, the corresponding integral line of X is defined on the whole interval $[0, 1]$. If X has complete integral lines then it *generates a diffeotopy of N* , that is there is a unique diffeotopy $G = G_X$ such that $X = X_G$. This establishes a bijection between diffeotopies and such tangent vector fields X with complete integral lines.

If N is not compact, not every X has complete integral lines; by local existence and uniqueness, in general, for every $(x, 0)$ there is a maximal open interval $[0, t_x) \subset [0, 1]$ on which the corresponding integral line is defined. However, if we assume that $v(x, t)$ has *compact support*, then it is not hard to show that X actually has complete integral lines, and the generated diffeotopy G_X has compact support. Recall that the support of $v(x, t)$ is defined as the closure in N of the set

$$\{x \in N \mid \exists t \in [0, 1], v(x, t) \neq 0\}.$$

Viceversa, if a diffeotopy G has compact support, then also v_G has compact support. This restricts the above bijection to diffeotopies and such tangent vector fields with compact support, and gives us a very flexible way to construct diffeotopies, under mild compactness assumptions. Finally we can state and prove our extension theorem (sometimes known as “Thom’s lemma”).

PROPOSITION 7.2. *Let $F : M \times [0, 1] \rightarrow N$ be an isotopy of embeddings of the compact boundaryless smooth m -manifold M into the boundaryless n -manifold N . Then F extends to an ambient isotopy of N with compact support.*

Proof: Consider the track \hat{F} of the isotopy F . It is a level preserving embedding of $M \times [0, 1]$ onto a compact proper submanifold say \hat{M} of $N \times [0, 1]$. Consider the constant vertical tangent vector field on $M \times [0, 1]$

$$V_M(x, t) = (0, 1) \in T_x M \times \mathbb{R}.$$

The tangent map $T\hat{F}$ sends V_M to a vector field X_M of the form

$$X_M(y, t) = (v_M(y, t), 1), y = f_t(x)$$

defined along \hat{M} . Then the idea is to extend X_M to a tangent vector field X of the form

$$X(y, t) = (v(x, t), 1)$$

defined on the whole of $N \times [0, 1]$ and such that $v(y, t)$ has compact support. The ambient isotopy G_X generated by the field X will eventually extend the isotopy F . Clearly this extension task only concerns the “horizontal” part v_M . Under the assumption made at the beginning of this section, we know from Chapter 5 that there are a proper compact tubular neighbourhood U of \hat{M} in $N \times [0, 1]$ (which restricts to a tubular neighbourhood of $f_t(M)$ in $N \times \{t\}$ for every $t \in [0, 1]$), and a compact submanifold with boundary W of N such that U is contained in $\text{Int}(W) \times [0, 1]$. By using the local product structure of U along \hat{M} , we can cover \hat{M} by a finite number of smooth closed $(n + 1)$ balls, each one say B easily supporting a smooth extension v_B of the restriction of v_M to $B \cap \hat{M}$, and such that their union is contained in U . Such B ’s can be incorporated in a nice covering with collar of $W \times [0, 1]$, say \mathcal{U} . Locally extend v_M on any open set of such a covering different

from the B 's by setting it constantly equal to 0. By using a partition of unity supported by \mathcal{U} , we finally get the required smooth extension of v_M to a smooth time depending field v defined on the whole of N , constantly equal to zero on the complement of W , and with compact support contained in W . □

REMARKS 7.3. (1) For the sake of simplicity, we have proved Thom's lemma under the assumption that both the compact manifold M and N are boundaryless. Mild adaptations of the same construction allow to extend the results under more general hypotheses. Assuming that both M and N possibly have boundary, we can cover for instance the following situations, getting a pertinent version of Thom's lemma (details are left to the readers):

- (a) F is an isotopy of embeddings of M either in $N \setminus \partial N$ or in ∂N .
- (b) F is an isotopy of proper embeddings of $(M, \partial M)$ in $(N, \partial N)$.
- (c) Every boundary component of ∂M is embedded by every f_t either in $N \setminus \partial N$ or in ∂N , being $f_t(M)$ transverse to ∂N along $f_t(M)$; for instance, this includes the case when for every t , f_t parametrizes a collar of a compact boundary component of ∂N .
- (d) For every $t \in [0, 1]$, f_t parametrizes a relative tubular neighbourhood of a compact proper submanifold $(Y, \partial Y)$ of $(N, \partial N)$.

(2) If M is not compact, in general an isotopy of embeddings of M in N does not extend to any diffeotopy. For example, take $M = \mathbb{R}$ and $N = \mathbb{R}^2$, then it is easy to construct an isotopy of embeddings connecting f_0 being the natural inclusion $\mathbb{R}_x \subset \mathbb{R}_{x,y}^2$ with f_1 having as image the set $\{(x, y); x^2 + (y-1)^2 = 1, (x, y) \neq (0, 2)\}$. For basic topological reasons it cannot be extended. On the other hand, what is really important to achieve the proof of Thom's lemma is that the isotopy F has compact support, even if M is possibly non compact.

As a corollary, we have also the following sort of relative extension result.

COROLLARY 7.4. *Let Y be a compact submanifold of the manifold M . Let F be an isotopy of embeddings of Y into the manifold N such that a version of Thom's lemma holds. Assume that f_0 can be extended to an embedding $h_0 : M \rightarrow N$. Then also f_1 can be extended to an embedding $h_1 : M \rightarrow N$; moreover we can require that h_0 and h_1 are diffeotopic to each other.*

Proof : By Thom's lemma F extends to a diffeotopy G of N , hence $h_1 := g_1 \circ h_0$ is an embedding of M in N which extends f_1 and is diffeotopic to h_0 by construction. □

7.2. Gluing manifolds together along boundary components

Let M_1 and M_2 be m -compact manifolds with boundary, V_1 and V_2 be unions of connected components of ∂M_1 and ∂M_2 respectively, and $\rho : V_1 \rightarrow V_2$ be a diffeomorphism. Consider the compact topological quotient space

$$M_1 \amalg_\rho M_2$$

by the equivalence relation on the disjoint union $M_1 \amalg M_2$ which identifies every $x \in V_1$ with $\rho(x) \in V_2$; ρ is called the *gluing map*. Denote by

$$q : M_1 \amalg M_2 \rightarrow M_1 \amalg_\rho M_2$$

the projection onto the quotient space, for $s = 1, 2$,

$$i_s : M_s \rightarrow M_1 \amalg M_2$$

the inclusion, and finally set

$$j_s = q \circ i_s .$$

It is clear that j_s is a homeomorphism onto its image. We have:

PROPOSITION 7.5. *The quotient space $M_1 \amalg_\rho M_2$ can be endowed with a structure of smooth m -manifold such that for every $s = 1, 2$, j_s is a smooth embedding, and*

$$\partial(M_1 \amalg_\rho M_2) = (\partial M_1 \amalg \partial M_2) \setminus (V_0 \amalg V_1) .$$

Proof : Fix a collar $c_1 : [-1, 0] \times V_1 \rightarrow M_1$ of V_1 in M_1 and a collar $c_2 : V_2 \times [0, 1] \rightarrow M_2$ of V_2 in M_2 . Define $\psi_V : (-1, 1) \times V_1 \rightarrow M_1 \amalg_\rho M_2$ by

$$\psi_V(t, x) = j_1(c_1(t, x)) \text{ if } t \in (-1, 0], \quad \psi_V(t, x) = j_2(c_2(\rho(x), t)) \text{ if } t \in [0, 1) .$$

It is clear that ψ_V is a homeomorphism onto an open neighbourhood U of

$$V := j_1(V_1) = j_2(V_2)$$

in $M_1 \amalg_\rho M_2$. By composing the charts of a smooth atlas of $(-1, 1) \times V_1$ with $\phi_V = \psi_V^{-1}$ we get a smooth atlas say \mathcal{U}_V on U such that ψ_V becomes tautologically a diffeomorphism. Similarly, let \mathcal{U}_s be a smooth atlas on $j_s(M_s \setminus V_s)$ such that the restriction of j_s to $M_s \setminus V_s$ is tautologically a diffeomorphism. It is immediate to check that $\mathcal{U}_V \cup \mathcal{U}_1 \cup \mathcal{U}_2$ is a smooth atlas on $M_1 \amalg_\rho M_2$ that determines a smooth manifold structure with the required properties. An equivalent way to get such a smooth structure on $M_1 \amalg_\rho M_2$ is as follows: take the disjoint union $(M_1 \setminus V_1) \amalg (M_2 \setminus V_2)$ and identify the two open sets $c_1((-1, 0) \times V_1)$ and $c_2((0, 1) \times V_2)$ by identifying $(t, x) \in (-1, 0) \times V_1$ with $(1 - t, \rho(x)) \in (0, -1) \times V_2$. □

Let us say that a smooth structure on $M_1 \amalg_\rho M_2$ obtained so far is given by *gluing M_1 and M_2 together by means of the gluing map ρ* . Such a smooth structure depends on the choice of collars entering the construction. However we have the following *uniqueness up to diffeomorphism*. Precisely:

PROPOSITION 7.6. *Any two smooth structures given by gluing M_1 and M_2 together via the gluing map ρ are diffeomorphic to each other, via a diffeomorphism which is the identity at the boundary.*

Proof : Assume for simplicity that two implementations of the construction differ by the choice of two different collars $c_2, c'_2 : V_2 \times [0, 1] \rightarrow M_2$. Denote by M and M' the respective smooth structures on $M_1 \amalg_\rho M_2$. The isotopy (relative to V_2) of the two collars of V_2 in M_2 extends to a diffeotopy G of M_2 . Then the map $h : M \rightarrow M'$ such that $h = \text{id}_{j_1(M_1)}$ on $j_1(M_1)$, $h = g_1 \circ (j_2)^{-1}$ on $j_2(M_2)$ provides a required diffeomorphism. The general case is achieved by a similar argument. □

Hence it makes sense to denote by $M_1 \amalg_\rho M_2$ such a diffeomorphism class of smooth manifolds obtained by gluing M_1 and M_2 together. In fact *we will often do the abuse to confuse such a class with any representative*.

In some cases we can deduce that $M_1 \amalg_\rho M_2$ and $M_1 \amalg_{\rho'} M_3$ are diffeomorphic, where $\rho : V_1 \rightarrow V_2$, $\rho' : V_1 \rightarrow V_3$ are respective gluing maps.

PROPOSITION 7.7. (1) *If the diffeomorphism $\rho' \circ \rho^{-1} : V_2 \rightarrow V_3$ extends to a diffeomorphism $h : M_2 \rightarrow M_3$. Then $M_1 \amalg_\rho M_2$ and $M_1 \amalg_{\rho'} M_3$ are diffeomorphic.*

(2) *If two gluing maps $\rho_0, \rho_1 : V_1 \rightarrow V_2$ are isotopic, then the manifolds obtained by gluing M_1 and M_2 together by means of ρ_0 and ρ_1 respectively are diffeomorphic to each other.*

Proof : A collar of V_3 in M_3 , used to define a smooth structure of $M_1 \amalg_{\rho'} M_3$, can be lifted by h to a collar of V_2 in M_2 ; this can be used to define a smooth structure of $M_1 \amalg_\rho M_2$ which by construction is diffeomorphic to $M_1 \amalg_{\rho'} M_3$. This achieves (1).

As for (2), $\rho_1 \circ \rho_0^{-1}$ is diffeotopic to the identity of V_2 which obviously extends to the identity of the whole M_2 . By Corollary 7.4, then also $\rho_1 \circ \rho_0^{-1}$ extends to a diffeomorphism of M_2 and we can apply previous item (1).

□

Oriented version. Keeping the above setting, assume furthermore that M_s is oriented and that V_s is part of the *oriented boundary* ∂M_s . If $\rho : V_1 \rightarrow V_2$ is a *orientation reversing* diffeomorphism then $M_1 \amalg_\rho M_2$ is endowed with a structure of *oriented* smooth m -manifold such that j_1 and j_2 are *orientation preserving embeddings*. Up to orientation preserving diffeomorphism it is well defined the oriented manifold $M_1 \amalg_\rho M_2$ which actually only depends on the isotopy class of the orientation reversing attaching diffeomorphism ρ .

7.3. On corner smoothing

Of course the notion of smooth manifold with corners (extending Definition 2.30) makes sense in the abstract setting. Making use of tubular neighbourhoods and collars as in the previous section, it is not hard to see that every compact smooth m -manifold with corner M verifies the following properties:

- M is a topological m -manifold and contains a boundaryless compact smooth $(m-2)$ -manifold L (the corner locus) such that $M \setminus L$ is a smooth m -manifold with boundary.
- There is an open neighbourhood U of L in M and a homeomorphism

$$\phi : U \rightarrow L \times [0, 1) \times [0, 1)$$

such that for every $x \in L$, $\phi(x) = (x, 0, 0)$, and the restriction of ϕ to $U \setminus L$ is a diffeomorphism onto $L \times [0, 1) \times [0, 1) \setminus L \times \{(0, 0)\}$.

By using these data we can prove that

There is a natural corner smoothing procedure that gives a smooth structure on M which is compatible with the given smooth structures on L and $M \setminus L$.

For let us fix a homeomorphism $\tau : [0, 1) \times [0, 1) \rightarrow B^2(0, 1) \cap \mathbf{H}^2$ which is a diffeomorphism outside $(0, 0)$ (for instance do it by using polar coordinates). Then set

$$\tau' : L \times [0, 1) \times [0, 1) \rightarrow L \times (B^2(0, 1) \cap \mathbf{H}^2), \quad \tau'(x, y, z) = (x, \tau(y, z))$$

and take the composition $\tau' \circ \phi : U \rightarrow L \times (B^2(0, 1) \cap \mathbf{H}^2)$. Take on U the differential structure such that $\tau' \circ \phi$ is tautologically a diffeomorphism. A smooth atlas of this structure together with a smooth atlas of $M \setminus L$ make a smooth atlas on M which by construction is compatible with the given smooth structures. Note that the induced smooth structure on ∂M coincides up to diffeomorphism with the one obtained by gluing the closure of the components of $\partial M \setminus L$ along the common boundary. Similarly to Proposition 7.6 *the corner smoothing produces a unique smooth structure up to diffeomorphism* (we left the details as an exercise).

7.4. Uniqueness of smooth disks up to diffeotopy

Let M be a smooth boundaryless m -manifold; a smooth embedding

$$\beta : D^m \rightarrow M$$

of the closed unitary m -disk is called a *smooth m -disk* in M . If M is oriented, two smooth m -disks in M are *co-oriented* if both preserve or reverse the orientation, provided that D^m inherits the standard orientation of \mathbb{R}^m .

We have

PROPOSITION 7.8. *Let M be a connected smooth boundaryless m -manifold. Let $\beta_r : D^m \rightarrow D_r \subset M$, $r = 0, 1$ be smooth m -disks in M . Then*

(1) *If M is oriented and β_0 and β_1 are co-oriented, then there is a diffeotopy of M which connects β_0 and β_1 . In particular there is an oriented smooth automorphism f of M such that $\beta_2 = f \circ \beta_1$.*

(2) If M is not orientable then there is a diffeotopy of M which connects β_0 and β_1 . In particular there is a smooth automorphism f of M such that $\beta_2 = f \circ \beta_1$.

Proof : In both cases, thanks to the homogeneity of M , possibly by composing β_1 with a diffeotopy, we can assume that $x_0 = \beta_0(0) = \beta_1(0)$. Possibly up to radial isotopies centred at 0, we can assume that both β_0 and β_1 have image contained in a chart $\phi : W \rightarrow \mathbb{R}^m$ of M such that $\phi(x_0) = 0$. Then we are reduced to the case $M = \mathbb{R}^m$, $\beta_r(0) = 0$. Assume that the two disks are co-oriented. Then we can easily adapt the proof of Proposition 1.17 and conclude that both β_r are isotopic to a same linear embedding of the disk in \mathbb{R}^m . By applying Thom's lemma we achieve (1).

If M is not orientable, a priori the two disks localized in a chart at x_0 as above might be not co-oriented. However, by the non-orientability of M , we can find a smooth simple loop λ based at x_0 such that by "sliding" say β_1 along λ we return back with the opposite orientation. Then up to isotopy we can always reduce to two co-oriented disks in \mathbb{R}^m and conclude as before. \square

7.5. Connected sum, shelling

Let us describe a further cut-and-paste procedure to construct compact manifolds.

- Let M_1 and M_2 be boundaryless, connected, compact smooth m -manifolds, $m \geq 1$.
- For $s = 1, 2$, let

$$\delta_s : D^m \rightarrow D_s \subset M_s$$

be a smooth embedding.

- Consider $\tilde{M}_s = M_s \setminus \text{Int}(D_s)$. Then \tilde{M}_s is a compact smooth manifold with one boundary component V_s diffeomorphic to S^{m-1} .
- Let $\rho : V_1 \rightarrow V_2$, $\rho = \rho(\delta_1, \delta_2)$ being the diffeomorphism obtained by the restriction of $\delta_2 \circ \delta_1^{-1} : D_1 \rightarrow D_2$. Finally consider the compact boundaryless manifold

$$W := \tilde{M}_1 \amalg_{\rho} \tilde{M}_2 .$$

Here is an equivalent description of the smooth manifold W . Take the disjoint union

$$(M_1 \setminus \delta_1(0)) \amalg (M_2 \setminus \delta_2(0))$$

and for every $(u, t) \in S^{m-1} \times (0, 1)$ identify $\delta_1(tv)$ with $\delta_2((1-t)v)$.

Every W obtained by implementing this procedure is called *a connected sum of M_1 and M_2* .

There is a natural *oriented* version, where M_1 and M_2 are oriented and $\delta_2 \circ \delta_1^{-1}$ is orientation reversing. The resulting connected sum is naturally oriented in a compatible way with M_1 and M_2 .

Every connected sum depends on the choice of the smooth m -disks δ_j . We are going to analyze to which extent it is uniquely defined up to diffeomorphism.

PROPOSITION 7.9. *Let M_1 and M_2 be boundaryless, connected, compact smooth m -manifolds. Then*

(1) *If both M_1 and M_2 are oriented, then the oriented connected sum $M_1 \# M_2$ is well defined up to oriented preserving diffeomorphism (i.e. it does not depend on the choice of the embeddings δ_s , provided that $\delta_2 \circ \delta_1^{-1}$ reverses the orientation).*

(2) *If at least one among M_1 and M_2 is not orientable, then the connected sum $M_1 \# M_2$ is well defined up to diffeomorphism (i.e. it does not depend on the choice of the embeddings δ_s).*

Proof : If both manifolds are oriented, possibly by pre-composing the smooth disks with the reflection $(x_1, \dots, x_m) \rightarrow (-x_1, \dots, x_m)$, we can assume that the m -disks in M_1 preserve while the m -disks in M_2 reverse the orientation; if at least one is non orientable, say M_1 , while M_2 is orientable, then we can assume that the disks in M_2 are co-oriented. By Proposition 7.8, in every case the disks in M_1 or M_2 entering different implementations of the connected sum procedure are diffeotopic to each other. Then the proposition follows by several applications of Proposition 7.7. \square

REMARKS 7.10. (1) When it is well defined, strictly speaking $M_1 \# M_2$ denotes a diffeomorphism class of smooth manifolds. Again we will do often the abuse to confuse it with any representative.

(2) In the oriented case, if $-M$ denotes the connected oriented manifold M endowed with the opposite orientation, then it can happen that $M_1 \# M_2$ is not diffeomorphic to $-M_1 \# M_2$ via an orientation preserving diffeomorphism. They are diffeomorphic if there is an orientation preserving diffeomorphism between M_1 and $-M_1$.

(3) The discussion about the connected sum works as well for compact manifolds with boundary, provided that the disks are embedded in their interior.

7.5.1. Thick connected sum, shelling. Let us keep the above setting. Assume furthermore that M_s is a boundary component of ∂N_s of the compact $(m+1)$ -manifold N_s . Then we can consider the topological quotient space

$$N_1 \amalg_{\hat{\rho}} N_2$$

where $\hat{\rho} : D_1 \rightarrow D_2$ is equal to $\delta_2 \circ \delta_1^{-1}$. Arguing similarly to Section 7.2, it is not hard to show that this quotient space carries a natural structure of smooth $(m+1)$ -manifold with corners which, by corner smoothing, leads to a well defined smooth manifolds denoted

$$N_1 \hat{\#} N_2$$

compatible with the smooth inclusions of N_s ; moreover

$$\partial(N_1 \hat{\#} N_2) = (\partial N_1 \setminus M_1) \amalg (\partial N_2 \setminus M_2) \amalg (M_1 \# M_2).$$

Naturally everything is well defined (only) up to diffeomorphism, possibly in the oriented category.

DEFINITION 7.11. In the above setting, if $N_2 = D^{m+1}$, then we say that $N := N_1$ and $\tilde{N} := N \hat{\#} D^{m+1}$ are related by a shelling (along $M := M_1$).

We have

PROPOSITION 7.12. *If N and \tilde{N} are related by a shelling, then they are diffeomorphic, as well as $M \# S^m$ is diffeomorphic to M .*

The proof involves several applications of the extension of isotopies and the disk unicity as above. We left the details as an exercise. \square

7.5.2. Weak connected sum, twisted spheres. There is a weak variant of the connected sum procedure; by keeping the notations of the beginning of Section 7.5, at the end we take

$$\tilde{M}_1 \amalg_{\beta} \tilde{M}_2$$

where

$$\beta : V_1 \rightarrow V_2$$

is any diffeomorphism, that is we do not require that it is the restriction of the composition of m -disks $\delta_2 \circ \delta_1^{-1}$. In the oriented situation we require also that β

reverses the orientation. The essential difference between the original procedure is that β does not necessarily extend to a diffeomorphism $\hat{\beta} : D_1 \rightarrow D_2$ between the whole embedded smooth m -disks. If we incorporate this last requirement about β , the present weak procedure is equivalent to the previous one. Without such a further requirement, it is definitely different.

We call *smooth twisted m -sphere* any manifold obtained by implementing the weak connected sum procedure starting from $M_1 = M_2 = S^m$. We collect below a few (non exhaustive) important facts about this topic.

PROPOSITION 7.13. (1) *If $1 \leq m \leq 4$, then every diffeomorphism $\beta : S^{m-1} \rightarrow S^{m-1}$ extends to a diffeomorphism $\hat{\beta} : D^m \rightarrow D^m$; hence every m -weak (oriented) connected sum is a (oriented) m -connected sum.*

(2) *For every $m \geq 1$, every smooth twisted sphere is homeomorphic to S^m . If $1 \leq m \leq 4$ it is diffeomorphic to S^m .*

(3) *There are smooth twisted 7-spheres that are not diffeomorphic to S^7 .*

We limit to a few comments about the proofs, item by item.

(1): For every m , possibly by composing with a reflections along a hyperplane of \mathbb{R}^{m+1} , it is not restrictive to assume that β preserves the orientation of S^m .

The validity (or not) of item (1) is invariant on the isotopy class of β .

For $m = 1$, item (1) is immediate via linear parametrizations of the interval D^1 .

For $m = 2$, we prove that β is isotopic to the identity (which obviously extends to the identity of D^2). In fact, up to isotopy it is not restrictive to assume that β is the identity on an open sub-arc J of S^1 (diffeomorphic to $(0, 1)$). Let J' be another open sub-arc of S^1 such that $S^1 = J \cup J'$. We get an isotopy of β with the identity as follows

$$H(x, t) = x \text{ if } x \in J, H(x, t) = tx + (1 - t)\beta(x) \text{ if } x \in J' .$$

(Smale Theorem) For $m = 3$, item (1) is already non trivial and due to Smale [S1]; as above it is enough to prove that β is isotopic to the identity. A proof can be built by using special dynamical properties of integration of *planar* tangent vector fields, the so called *Poincaré-Bendixson Theory*. Up to isotopy we can assume that β is the identity on a hemisphere. So, via the stereographic projection, it is enough to prove that a diffeomorphism $g : \mathbb{R}^2 \rightarrow \mathbb{R}^2$ which is the identity outside the unitary disk D^2 is isotopic to the identity through diffeomorphisms sharing this property. Again up to isotopy it is not restrictive to assume that these diffeomorphisms are equal to the identity also on a collar of $S^1 = \partial D^2$ in D^2 . Consider the constant unitary vertical tangent field on \mathbb{R}^2 , $\mathbf{v}_0 = e_2$, and let \mathbf{v}_1 its image by means of the differential dg . These fields can be considered as smooth maps $\mathbf{v}_i : D^2 \rightarrow \mathbb{C}^*$ (completed by a constant map outside D^2). We can lift them to maps $\tilde{\mathbf{v}}_i : D^2 \rightarrow \mathbb{C}$ via the universal covering map $\exp : \mathbb{C} \rightarrow \mathbb{C}^*$. By taking the convex combinations $\tilde{\mathbf{v}}_t := t\tilde{\mathbf{v}}_1 + (1 - t)\tilde{\mathbf{v}}_0$, $t \in [0, 1]$, and projecting them back to \mathbb{C}^* , we get a homotopy \mathbf{v}_t between \mathbf{v}_0 and \mathbf{v}_1 through nowhere vanishing tangent vector fields which are constant outside D^2 minus a collar of S^1 . Now one would integrate the homotopy \mathbf{v}_t to a diffeotopy between g and the identity. This is a rather delicate task. A key dynamical property is that in the present situation *no maximal integral curves of \mathbf{v}_t are trapped in (the compact set) D^2* . In particular an integral line which crosses the upper semicircle of S^1 pointing inside D^2 , after a certain time crosses the lower semicircle pointing outside. By elaborating on this fact, one eventually constructs a desired isotopy of diffeomorphisms (for all details see also Section 6.4. of [Mart]).

For $m = 4$, (1) is difficult (see [Ce]).

(2): It is easy to extend every β as above to a *homeomorphism* $\hat{\beta} : D^m \rightarrow D^m$; we can get such a $\hat{\beta}$ by a radial extension sending for every $x \in S^{m-1}$, the interval

$[x, 0] \subset D^m$ linearly onto the interval $[\beta(x), 0]$ (this is also known as the *Alexander trick*). By the way, this is a diffeomorphism on $D^m \setminus \{0\}$, 0 being in general the only non smooth point. By using this fact it is easy to show that every twisted m -sphere is homeomorphic to S^m . For $1 \leq m \leq 4$ it is diffeomorphic to S^m thanks to item (1).

(3): These are the celebrated *Milnor's exotic 7-spheres* [M4].

REMARK 7.14. Let M be a compact oriented boundaryless smooth m -manifold. Let $Y \subset M$ be a submanifold diffeomorphic to S^{m-1} so that $M \setminus Y = M_1 \amalg M_2$ consists of two connected non compact manifolds. The closure \hat{M}_s of M_s in M is a compact manifold \hat{M}_s with boundary equal to Y . Let us glue to \hat{M}_s a disk D^m via a diffeomorphism $\rho_s : S^{m-1} \rightarrow Y$, obtaining two oriented boundaryless manifolds \tilde{M}_s . Then

$$M = \tilde{M}_1 \# \tilde{M}_2 .$$

In general this factorization of M is not unique. For example the standard S^7 can be expressed as $S^7 \# S^7$ as well as the connected sum of two exotic 7-spheres.

7.6. Attaching handles

This is a very important procedure. We will see in Chapter 9 that every compact manifold admits “handle decompositions” that is it can be built (up to diffeomorphism) by iterated applications of this basic attaching procedure.

For every $m \geq 0$, for every $0 \leq q \leq m$,

$$H^q = H^{q,m} = D^q \times D^{m-q}$$

is the *standard q -handle of dimension m* . If clear from the context, we will omit to indicate the dimension; q is also called the *index* of the handle. Strictly speaking such a handle H^q is a manifold with corner with boundary

$$\partial H^q = (S^{q-1} \times D^{m-q}) \cup (D^q \times S^{m-q-1}) ;$$

up to smoothing it is diffeomorphic to D^m endowed with a determined decomposition by submanifolds of $\partial D^m = S^{m-1}$.

Let us fix a few terminology.

- $\Sigma_a := S^{q-1} \times \{0\} \subset \mathcal{T}_a := S^{q-1} \times D^{m-q}$ are called respectively the *a-sphere* and the *a-tube* of H^q .
- $\Sigma_b := \{0\} \times S^{m-q-1} \subset \mathcal{T}_b := D^q \times S^{m-q-1}$ are called respectively the *b-sphere* and the *b-tube* of H^q .
- $C := D^q \times \{0\}$ is called the *core* of the handle.
- $C^* := \{0\} \times D^{m-q}$ is called the *co-core* of the handle.

Note that the *a-sphere* is the boundary of the core, the *b-sphere* is the boundary of the co-core; the core and the co-core intersect transversely only at $(0, 0)$. \mathcal{T}_a and \mathcal{T}_b intersect at the respective boundaries both equal to $S^{q-1} \times S^{m-q-1}$.

Let N be a compact smooth m -manifold with boundary. Given a q -handle H^q of dimension m , let $h : \mathcal{T}_a \rightarrow \partial N$ be a smooth embedding. Then $S_a := h(\Sigma_a)$ is the *embedded (attaching) a-sphere*; $T_a := h(\mathcal{T}_a)$ is a tubular neighbourhood of S_a in ∂N , endowed by means of h of a *global trivialization*. T_a is also called the *embedded (attaching) a-tube*. Consider the topological quotient space

$$N \amalg_h H^q$$

by the equivalence relation on the disjoint union $N \amalg H^q$ which identifies every $x \in \mathcal{T}_a$ with $h(x) \in T_a$. Then $N \amalg_h H^q$ has a natural structure of manifold with corner which by smoothing leads to a smooth manifold well defined up to diffeomorphism. Considered up to diffeomorphism, we say that $N \amalg_h H^q$ is the smooth manifold obtained by attaching a q -handle to N via the attaching map h . At this point it is routine to apply as above the extension of isotopies to diffeotopies and get:

PROPOSITION 7.15. *Up to diffeomorphism, $N \amalg_h H^q$ only depends on the isotopy class of the attaching embedding h .*

□

Here is a few complements about attaching handles.

(1) Up to diffeomorphism, the boundary of $N \amalg_h H^q$ is given by

$$\partial(N \amalg_h H^q) = (\partial N \setminus \text{Int}(T_a)) \amalg_{h|_{\partial\mathcal{T}_b}} \mathcal{T}_b ;$$

sometimes we denote it by

$$\sigma(\partial N, h)$$

and call it the $(m-1)$ -manifold obtained by *surgery* on ∂N with *surgery data* h .

(2) If N is oriented and $q > 1$, then also $N \amalg_h H^q$ can be oriented in a compatible way. In fact as $q > 1$, the a -tube is connected and we can take the orientation of H^q such that the gluing diffeomorphism $h : \mathcal{T}_a \rightarrow T_a$ reverses the orientation. For $q = 1$, \mathcal{T}_a is not connected and it is not always possible to make h orientation reversing on both components. Attaching 1-handles is the only case which imposes some constraints in order to perform the construction within the oriented category.

(3) If N is connected and $q > 1$, then also $N \amalg_h H^q$ is connected. In fact the connected T_a is contained in one connected component of ∂N and by attaching H^q , which is connected, connectedness is preserved. By attaching a 1-handle we can reduce the number of connected components by 1. This happens if the connected components of T_a belong to different components of ∂N .

(4) The a -tube of a 0-handle is empty; then attaching a 0-handle to N means to “create” a new connected component diffeomorphic to D^m . The a -tube of a m -handle is the whole boundary of D^m . Hence by attaching a m -handle we fill a spherical component of ∂N (if any, otherwise we cannot attach any m -handle).

(5) Up to diffeomorphism, the thick connected sum can be rephased in terms of attaching a 1-handle to N_1 and N_2 with one component of T_a in ∂N_1 and the other in ∂N_2 . Similarly by suitably attaching a 1-handle to

$$(M_1 \times [0, 1]) \amalg (M_2 \times [0, 1])$$

we get a manifold W such that

$$\partial W = (M_0 \amalg M_1) \amalg (M_1 \# M_2)$$

(possibly in the oriented category).

REMARK 7.16. Attaching a handle is an instance of the following more general gluing procedure: for $j = 1, 2$, let Y_j be a $(m-1)$ sub-manifold with boundary ∂Y_j of $\partial M_j \subset M_j$. Let $\rho : Y_1 \rightarrow Y_2$ be a diffeomorphism. Then $M_1 \amalg_\rho M_2$ is in a natural way a m -manifold with corners, hence a well defined smooth manifold up to corner smoothing (and up to diffeomorphism).

7.7. Strong embedding theorem, the Whitney Trick

The aim of this section is to provide information about the following theorem, the proof introduces the very important so called “Whitney trick” [Whit2].

THEOREM 7.17. *Every compact boundaryless smooth m -manifold M can be embedded into \mathbb{R}^{2m} .*

A sketch of proof. We limit to a rough outline of the proof, stressing anyway that it is substantially different from the weak immersion/embedding theorem 6.8. This last is entirely based on so called “general position arguments” or, equivalently, on *transversality* (concepts that we will develop in Chapter 8 although we are anticipating a few applications). By pushing the general position arguments (see Section 8.2), we can at most refine the weak immersion theorem and get that a

“generic immersion”, say $\pi : M \rightarrow \mathbb{R}^{2m}$, of our compact boundaryless m -manifold in \mathbb{R}^{2m} has the further properties:

The inverse image of every point in $\pi(M) \subset \mathbb{R}^{2m}$ consists in at most 2 points; if $\pi(p) = \pi(p') = q$, then $\mathbb{R}^{2m} = d_p\pi(T_pM) \oplus d_{p'}\pi(T_{p'}M)$. Then, by compactness of M , there is in the image of π a finite number of such “simple normal crossing points”.

We can start with such a generic immersion. If there are normal crossing points, they persist under any small perturbation of the immersion. To get an embedding we must operate a robust modification of π . Basically there are two “moves”:

- (1) Introduce if necessary a further crossing point.
- (2) Eliminate a couple of double points by applying the so called *Whitney Trick*.

As we are going to see, this scheme actually works for $m \neq 2$; fortunately for $m = 2$, the strong embedding theorem holds as a corollary of the *classification of smooth compact surfaces* (see Chapter 15). So we definitively assume here that $m \neq 2$. Moreover it is not restrictive to assume that M is connected.

- The basic local model for a single self-intersection point is as follows:

$$\alpha : \mathbb{R}^m \rightarrow \mathbb{R}^{2m}, \quad \alpha(t_1, t_2, \dots, t_m) = \left(t_1 - \frac{2t_1}{u}, t_2, \dots, t_m, \frac{1}{u}, \frac{t_1t_2}{u}, \frac{t_1t_3}{u}, \dots, \frac{t_1t_m}{u} \right)$$

where

$$u = (1 + t_1^2)(1 + t_2^2) \cdots (1 + t_m^2).$$

It is an embedding except for the points $(1, 0, \dots, 0), (-1, 0, \dots, 0)$ which are sent to $0 \in \mathbb{R}^{2m}$. Moreover, when $\|t\| \rightarrow +\infty$, α tends to the usual linear embedding $(t_1, \dots, t_m) \rightarrow (t_1, t_2, \dots, t_m, 0, \dots, 0)$ of $\mathbb{R}^m \subset \mathbb{R}^m \times \mathbb{R}^m = \mathbb{R}^{2m}$. To add such a double point to a given immersion π , we can do it locally in a chart at a point $q \in \pi(M)$ where at $q \sim 0$, $\pi(M)$ looks like the image of the above linear embedding. Then by using two suitable bump functions on \mathbb{R}^m at 0 and at infinity respectively, and the associated partition of unity, it is not hard to modify π to get one with one more self-intersection point.

REMARK 7.18. Give \mathbb{R}^m and \mathbb{R}^{2m} the standard orientation; then the single self-intersection point has a sign. Its mirror image has the opposite sign.

- The Whitney Trick applies at a *Whitney disk* D connecting two crossing points q_1, q_2 in $\pi(M)$. This means that the following pattern is realized:

(1) There is an embedded smooth circle γ in $\pi(M)$ with two corners at q_1 and q_2 ; these divide γ in two arcs with closures γ_1 and γ_2 respectively; these closed arcs $\gamma_j, j = 1, 2$, are contained into smooth open m -disks U_j in $\pi(M)$, their union is an open neighbourhood of γ in $\pi(M)$, they intersect transversely each other at $\{q_1, q_2\}$, and do not contain other crossing points of $\pi(M)$;

(2) There are:

- a 2-disk \mathcal{D} in \mathbb{R}^2 with boundary $\partial\mathcal{D}$ with two corners a_1, a_2 which is contained in the union of two smooth arcs λ_1, λ_2 in \mathbb{R}^2 which intersect transversely at $\{a_1, a_2\}$;
- an embedding $\psi : U \rightarrow \mathbb{R}^{2m}$ where U is an open 2-disk in \mathbb{R}^2 containing $\mathcal{D} \cup (\lambda_1 \cup \lambda_2)$, such that

- $\psi(\lambda_j) \subset U_j, j = 1, 2$;
- $\psi(\partial\mathcal{D}, \{a_1, a_2\}) = (\gamma, \{q_1, q_2\})$;
- for every $x \in \lambda_j, j=1,2, d_x\psi(T_xU) \cap T_{\psi(x)}U_j = d_x\psi(T_x\lambda_j)$;
- $\psi(\text{Int}(\mathcal{D})) \subset \mathbb{R}^{2m} \setminus \pi(M)$.

We summarize (1) and (2) by saying that the smooth 2-disk with corners $D := \psi(\mathcal{D})$ is *properly embedded* into $(\mathbb{R}^{2m}, \pi(M))$ and *connects the crossing points* q_1, q_2 .

Moreover, we require:

(3) We can extend the embedding ψ to a parametrization of a neighbourhood of D in \mathbb{R}^{2m} by a *standard model*, that is to an embedding

$$\Psi : U \times \mathbb{R}^{m-1} \times \mathbb{R}^{m-1} \rightarrow \mathbb{R}^{2m}$$

such that $\Psi(\lambda_1 \times \mathbb{R}^{m-1} \times \{0\}) = U_1$ and $\Psi(\lambda_2 \times \{0\} \times \mathbb{R}^{m-1}) = U_2$.

Thanks to such a standard model, it is not hard to realize that a Whitney disk (if any) can be used as a guide to construct a 1-parameter family of immersions, with compact support around D , by “pushing M across D ”, eventually removing q_1, q_2 without modifying the configuration of the other crossing points.

REMARK 7.19. We can fix local orientations around a Whitney disk. The required properties implies that the two crossing points connected by the disk have *opposite signs* with respect to such orientations

- To conclude the proof of the embedding theorem, we have to show that for every generic projection, possibly after having inserted a new crossing point (recall Remarks 7.18 and 7.19) there is a couple of crossing points connected by a Whitney disk which can be eliminated. For $m = 1$ this follows by somewhat subtle but elementary planar considerations. For $m > 2$, we will discuss this issue within a larger range of application of the Whitney trick in Chapter 18 (see Remark 7.20 (2) and Proposition 18.15).

□

REMARKS 7.20. (1) If $m = 2$, the circle γ can be constructed as well and one could construct a generically immersed disk D in \mathbb{R}^4 , bounded by γ , but we cannot exclude the existence of crossing points of D itself or of transverse intersection of D with $\pi(M)$ apart from γ .

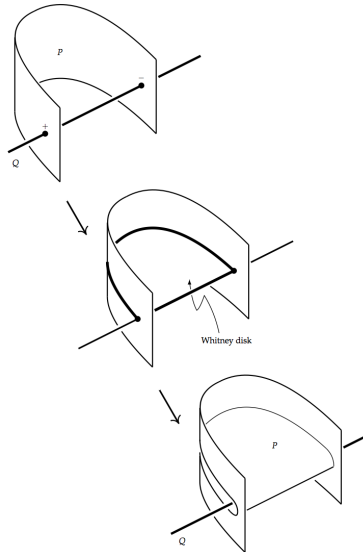

FIGURE 1. Whitney's trick.

(2) The notion of Whitney disk, hence the Whitney trick, can be extended to eliminate couple of tranverse intersections of two submanifolds P, Q of a given manifold M , such that $\dim M = \dim P + \dim Q$ (the boundary loop γ being formed by two arcs in P and Q respectively). This technique has been of absolute importance in the achievement of fundamental results for smooth manifolds of sufficiently high

dimension (see Chapter 18). The fact noticed above that the scheme does not apply in the case $\dim M = 4$ has been the ultimate reason for special and astonishing phenomena occurring in the realm of 4-manifolds. We will develop these comments much later in the text (see Chapter 20).

7.8. On immersions of n -manifolds in \mathbb{R}^{2n-1}

The aim of this section is to provide some information about the following hard immersion theorem [**Whit3**].

THEOREM 7.21. *Every compact boundaryless n -manifold M can be immersed into \mathbb{R}^{2n-1} .*

□

It is not restrictive to assume that M is connected. Similarly as in the discussion about the hard embedding theorem, “hard” means that it is not only based on general position arguments. This kind of arguments (mostly in the spirit of “multi-jet-transversality” - see Section 8.2) allows to preliminarily determine the *generic maps* $f : M \rightarrow \mathbb{R}^{2n-1}$ which in general are not immersions. For simplicity let us give a few details for $n = 2$ (the general case is similar). The local models of such a generic map are all realized by

$$g : \mathbb{R}_{u,v}^2 \rightarrow \mathbb{R}_{x,y,z}^3, \quad x = u^2, \quad y = v, \quad z = uv .$$

The line $\{v = 0\}$ is the non injectivity locus of this map and its image is a half line. The image of every other line $\{v = c\}$ is the parabole $x = (z/c)^2$ in the hyperplane $\{y = c\}$. The point $0 \in \mathbb{R}^2$ is the unique at which the map g is not an immersion and its image $0 = g(0)$ is called the *Whitney point* in the model. The transverse intersection with the image of g of a small sphere around the Whitney point is a wedge of two smooth circles. The restriction of g to $\mathbb{R}^2 \setminus \{0\}$ is a generic immersion, that is along the the image of $\{v = 0\} \setminus \{0\}$ there are two transverse branches of the images of g .

In general, we can describe qualitatively a generic maps $f : M \rightarrow \mathbb{R}^{2n-1}$ as follows. Assume first that $n \geq 3$. The image say Σ of the non injectivity locus is a compact 1-dimensional submanifold of \mathbb{R}^{2n-1} possibly with boundary; $W = \partial\Sigma$ is formed by the so called Whitney points of f . The restriction of f to $\tilde{W} := f^{-1}(W)$ is a bijection onto its image and f is not an immersion at every point of \tilde{W} . $\tilde{\Sigma} := f^{-1}(\Sigma \setminus \partial\Sigma)$ is a smooth (non compact) 1-submanifold of M and the restriction of f to $\tilde{\Sigma}$ is a double covering map onto the interior of Σ . The restriction of f to $M \setminus \tilde{W}$ is a generic immersion, so that locally along every component of the interior of Σ , there are two transverse branches of the image of f .

If $n = 2$ the situation is a bit more complicated. In fact beyond the Whitney points, Σ has in general also a finite set of three branches crossing points (the “triple points” of the image) at which the local model for the generic immersion of $M \setminus \tilde{W}$ is given by three hyperplanes of \mathbb{R}^3 in general position.

These generic maps are *stable* in the sense that their qualitative features are preserved up to small smooth perturbations. Starting from a generic map $f : M \rightarrow \mathbb{R}^{2n-1}$, we have to perform a robust alteration of it in order to get an immersion $\hat{f} : M \rightarrow \mathbb{R}^{2n-1}$. The Whitney points are partitioned by couples of points which are connected by a smooth arc contained in Σ . Then we perform a kind of rather subtle “surgery” along each such an arc γ . To give an idea, assume that $n = 2$ and that, for simplicity, the arc γ connecting two Whitney points does not include triple points. Remove from $f(M)$ the intersection with the interior of a small smooth “ ϵ -neighbourhood” U (diffeomorphic to D^3) of γ in \mathbb{R}^3 whose boundary intersects transversely $f(M)$ at two smooth circles; then fill them by two disjoint embedded 2-disks. In this way we get Σ' from which two Whitney points have been eliminated;

in fact Σ' is the image of the non injectivity locus of a generic map $f' : M' \rightarrow \mathbb{R}^3$, where M' is a surface obtained from M by cutting and pasting. To eventually restore a map $f'' : M \rightarrow \mathbb{R}^3$ one connects again the above 2-disks by attaching a suitably oriented 1-handle embedded into the smooth 3-disk U . By doing it along every arcs γ we eventually get a desired generic immersion $\hat{f} : M \rightarrow \mathbb{R}^3$. Moreover, \hat{f} can be obtained arbitrarily close to the given generic map f in the C^0 -topology.

7.8.1. On Smale-Hirsch immersion theory. Whitney's hard immersions theorem has been reobtained later as a non trivial application of Hirsch immersion theory [H2]. Extending early Smale's results in the case when M is a sphere, this faces the general question of the existence of immersions $f : M \rightarrow N$, $n = \dim N > \dim M = m$, and the classification of immersions in a given homotopy class of maps from M to N up to regular homotopy (two immersions $f_0, f_1 : M \rightarrow N$ are *regularly homotopic* if they are connected by a homotopy f_t such that for every $t \in [0, 1]$, f_t is an immersion). Remarkably these questions are translated into homotopy theoretic problems. When $N = \mathbb{R}^{m+k}$, $k \geq 1$, the existence problem can be translated as follows. By the easy Whitney immersion theorem, there are immersions $f : M \rightarrow \mathbb{R}^{m+m}$, and by using the standard metric g_0 on \mathbb{R}^{m+m} we have the induced normal map

$$\nu_f : M \rightarrow \mathfrak{G}_{2m,m}, \quad \nu_f(x) = (d_x f(T_x M))^\perp.$$

Then there exists an immersion $\hat{f} : M \rightarrow \mathbb{R}^{m+k}$, $1 \leq k \leq m$ if and only if there exists an immersion f as above and a map

$$\hat{\nu} : M \rightarrow \mathfrak{G}_{m+k,k}$$

such that the vector bundle $\hat{\nu}^*(\mathcal{V}_{m+k,k})$ is weakly stably isomorphic to $\nu_f^*(\mathcal{V}_{2m,m})$. By the classification of vector bundles on compact manifolds, this is equivalent to establish a homotopy between classifying maps. Moreover, given such a map $\hat{\nu}$, there is an immersion \hat{f} such that $\hat{\nu} = \nu_{\hat{f}}$.

When $N = \mathbb{R}^{m+k}$, all immersions are homotopic to each other; it turns out that f_0 and f_1 are regularly homotopic if and only if the bundle maps $[\nu_{f_0}, \nu_{f_0}^*]$ and $[\nu_{f_1}, \nu_{f_1}^*]$ are homotopic through bundle maps over a (ordinary) homotopy connecting f_0 and f_1 .

The following corollary is immediate.

COROLLARY 7.22. *If M is parallelizable then it can be immersed into \mathbb{R}^{m+k} for every $k \geq 1$.*

□

For every $m \geq 0$, let $i(m)$ be the minimum $k \geq 1$ such that every compact boundaryless m -manifold M can be immersed into \mathbb{R}^{m+k} . By the hard Whitney immersion theorem, we have that $i(m) \leq m - 1$. By using the above translation of the problem into (hard) homotopy theoretic ones, we eventually know the exact value of $i(m)$, see [1].

THEOREM 7.23. *For every $m \geq 0$, $i(m) = m - \alpha(m)$, where $\alpha(m)$ is the number of 1 in the dyadic expansion of m .*

7.9. Embedding n -manifolds in \mathbb{R}^{2n-1} up to surgery

By construction if we use Whitney's method or perturbing an immersion $f : M \rightarrow \mathbb{R}^{2n-1}$ whose existence is an application of Hirsch results, we can assume anyway to deal with *generic* immersions, M being any compact connected boundaryless n -manifold. So if $n \geq 3$, adopting the above notations, Σ is a compact boundaryless 1-submanifold of \mathbb{R}^{2n-1} . For every component C of Σ , locally along C we see two transverse branches of the image of f ; $\tilde{C} := f^{-1}(C)$ is a compact

boundaryless 1-submanifold of M and the restriction of f to \tilde{C} is a 2-folds covering which a priori can be non trivial (\tilde{C} connected) or trivial (\tilde{C} with two connected components).

The main aim of this section is to show that starting from a generic immersion $f : M \rightarrow \mathbb{R}^{2n-1}$ as above, by attaching suitable “round handles” to $M \times [0, 1]$ at $M \times \{1\}$ we get a $(n + 1)$ -manifolds W such that $\partial W = M \amalg \hat{M}$ (hence \hat{M} is obtained by a kind of “surgery” on M) and f can be altered on \hat{M} to get an embedding $\hat{f} : \hat{M} \rightarrow \mathbb{R}^{2n-1}$. This construction is due to Rohlin (see the translations of his papers in [GM]) and will be used in Chapters 19 and 20.

Let us analyze more closely the properties of such a generic immersion. C has a tubular neighbourhood $U \sim C \times D^n$ in \mathbb{R}^{2n-1} such that $\tilde{U} := f^{-1}(f(M) \cap U)$ is a tubular neighbourhood of \tilde{C} in M . A priori there are two possibilities for U . Either it is identified with the mapping cylinder of

$$h_0 : D^n \times D^n \rightarrow D^n \times D^n, \quad h_0(y, z) = (z, y)$$

or to the mapping cylinder of

$$h_1 : D^n \times D^n \rightarrow D^n \times D^n, \quad h_1(y, z) = (y, z).$$

In both cases, the subset

$$X := (\{0\} \times D^n) \cup (D^n \times \{0\})$$

is h_j -invariant, $j = 0, 1$, and the mapping cylinder of the restriction of h_j to X realizes the image $f(\tilde{U})$ in U . The tubular neighbourhood \tilde{U} can be realized respectively either as the mapping cylinder of

$$g_0 : \{0, 1\} \times D^n \rightarrow \{0, 1\} \times D^n, \quad g_0(u, x) = (1 - u, x)$$

or of

$$g_1 : \{0, 1\} \times D^n \rightarrow \{0, 1\} \times D^n, \quad g_1(u, x) = (u, x)$$

and in both cases, the restriction of f to \tilde{U} can be expressed as

$$f(u, x, t) = (ux, (1 - u)x, t).$$

The first case would correspond to the non trivial covering $\tilde{C} \rightarrow C$; the second to the trivial one. However, as \mathbb{R}^{2n-1} is orientable, then also U must be orientable and one easily sees that this constraint cannot be realized in the first case if n is even. So we have proved

LEMMA 7.24. *If $n = \dim M \geq 3$ is even only trivial coverings $\tilde{C} \rightarrow C$ can occur.*

□

We are going now to construct W , $\partial W = M \amalg \hat{M}$ and the embedding $\hat{f} : \hat{M} \rightarrow \mathbb{R}^{2n-1}$ with the desired features. Let C be a component of Σ . Use the above models for the neighbourhoods U, \tilde{U} . Consider $\frac{1}{2}\tilde{U} \subset \tilde{U}$ obtained as the mapping cylinder of the restriction of g_j to $\{0, 1\} \times \frac{1}{2}D^n$ and set

$$\tilde{U}' := \tilde{U} \setminus \text{Int} \frac{1}{2}\tilde{U}.$$

Define the map

$$\hat{f} : \tilde{U}' \rightarrow U$$

by

$$\hat{f}(0, x, t) = (\phi(|x|)(-x_1, x_2, \dots, x_n), x, t), \quad \hat{f}(1, x, t) = (x, \phi(|x|)(-x_1, x_2, \dots, x_n), t)$$

where $x = (x_1, \dots, x_n)$ and

$$\phi : [1/2, 1] \rightarrow [0, 1]$$

is a smooth strictly decreasing function which coincides with $t \rightarrow -t + 1/2$ near $t = 1/2$, $\phi(1) = 0$ and ϕ is flat at 1. The image of \hat{f} in U is the mapping cylinder

of the restriction of h_j to an invariant subset \tilde{X} of $D^n \times D^n$ which coincides with X near the boundary. \tilde{X} is diffeomorphic to two disjoint copies of D^n hence it “desingularizes” X . The map \hat{f} extends to the whole of $M \setminus \text{Int} \frac{1}{2} \tilde{U}$ by taking the restriction of f to $M \setminus \tilde{U}$. Do it for every component of Σ (by using pairwise disjoint tubular neighbourhoods). Thus we have obtained a n -submanifold, say \tilde{M} , of \mathbb{R}^{2n-1} which is the image of a smooth map $\hat{f} : M_0 \rightarrow \mathbb{R}^{2n-1}$, where M_0 is a submanifold with boundary of M obtained by removing a system of small open tubular neighbourhoods of the \tilde{C} ’s. It turns out that the quotient

$$\hat{M} := M_0 / \hat{f}$$

is in a natural way a boundaryless compact manifold and the induced map (we keep the name)

$$\hat{f} : \hat{M} \rightarrow \tilde{M}$$

is a diffeomorphism. For every component C , the identification induced by \hat{f} at the corresponding boundary components of M_0 is given by

$$(u, x_1, x_2, \dots, x_n, t) \sim (1 - u, -x_1, x_2, \dots, x_n, t).$$

It remains to describe the “handles” attached to $M \times [0, 1]$ at $M \times \{1\}$ producing a $(n + 1)$ -manifold W such that $\partial W = M \amalg \hat{M}$. There is one such a handle for every component C . If $\tilde{C} \rightarrow C$ is the trivial covering, let H be the mapping cylinder of the identity of $[0, 1] \times D^n$. Then attach H at $M \sim M \times \{1\}$ along \tilde{U} , by means of the attaching map which identifies $(0, x, t)$ (resp. $(1, x, t)$) of H with $(0, x, t)$ ($(1, x, t)$) of \tilde{U} . If $\tilde{C} \rightarrow C$ is non trivial (recall that it happens only if n is odd) then we do similarly by using the mapping cylinder \tilde{H} of the map

$$k : [0, 1] \times D^n \rightarrow [0, 1] \times D^n, \quad k(v, x_1, x_2, \dots, x_n) = (1 - v, -x_1, x_2, \dots, x_n).$$

This complete the construction. We stress that by the very construction:

If M is orientable then also the $(n + 1)$ -manifold W constructed so far and the manifold \hat{M} embedded in \mathbb{R}^{2n-1} such that $\partial W = M \amalg \hat{M}$ are orientable.

REMARK 7.25. The constructions and the considerations of this section hold by starting from any generic immersion $f : M \rightarrow W$ from a compact (possibly orientable) boundaryless n -manifold into an arbitrary (possibly orientable) $(2n - 1)$ -manifold W .

7.10. Projectivized vector bundles and blowing up

\mathbb{R}^n can be considered as a vector bundle over the 0-manifold $M = \{0\}$. The projective space $\mathbf{P}^{n-1}(\mathbb{R})$ can be considered as a fibration over M which “projectivizes” the given vector bundle. If

$$\xi := p : E \rightarrow M$$

is any vector bundle (for example the tangent bundle), over a compact m -manifold M with fibre \mathbb{R}^n , we can perform the above projectivization fibre by fibre and obtain a fibration

$$\mathbf{p} : \mathbf{P}(E) \rightarrow M$$

with fibre \mathbf{P}^{n-1} . Every local trivialization $W \times \mathbb{R}^n \sim p^{-1}(W)$ of the vector bundle gives rise to a local trivialization $W \times \mathbf{P}^{n-1} \sim \mathbf{p}^{-1}(W)$. If (E, p) is defined by means of a cocycle $\{\mu_{i,j} : W_i \cap W_j \rightarrow \text{GL}(n, \mathbb{R})\}$, then it induces a cocycle with values in the projectivized linear group $\mathbf{PGL}(n, \mathbb{R})$ that defines $(\mathbf{P}(E), \mathbf{p})$. The total space $\mathbf{P}(E)$ is a compact manifold of dimension $m + n - 1$. A point in $\mathbf{P}(E)$ is a line l_x in $E_x = p^{-1}(x)$ for some $x \in M$. We can pull-back ξ to $\mathbf{P}(E)$ via the projection \mathbf{p} and obtain the vector bundle $\mathbf{p}^*(\xi)$ over $\mathbf{P}(E)$. We note that the restriction of $\mathbf{p}^*(\xi)$

to every fibre of \mathbf{p} is a product (trivial) bundle. Moreover, $\mathbf{p}^*(\xi)$ has a canonical *tautological* sub-bundle of rank 1 (i.e. a line bundle) λ_ξ : the total space is

$$\Lambda_\xi = \{(l_x, v) \in \mathbf{p}^*(\xi); v \in l_x\}$$

with the natural projection onto $\mathbf{P}(E)$. Its fibre over l_x is the line contained in the fibre of $\mathbf{p}^*(\xi)$ at l_x , made by the vectors belonging to l_x . By using for instance an auxiliary riemannian metric on the total space of $\mathbf{p}^*(\xi)$ we realize that up to strict equivalence it canonically splits as a direct sum

$$\mathbf{p}^*(\xi) \sim \lambda_\xi \oplus \beta_\xi$$

where also the bundle β_ξ is well defined up to strict equivalence. By iterating this construction starting again from β_ξ , we eventually get

PROPOSITION 7.26. *For every vector bundle $\xi : E \rightarrow M$ over a compact manifold M , there is a canonical construction (via iterated projectivization of vector bundles) that produces a smooth compact manifold $F(\xi)$ endowed with a surjective smooth map*

$$f_\xi : F(\xi) \rightarrow M$$

such that the vector bundle $f_\xi^*(\xi)$ over $F(\xi)$ splits as a direct sum of line bundles. In particular this applies to the tangent bundle of M .

□

7.10.1. Blowing up along smooth centres. Let us start with the blowing up of \mathbb{R}^n , $n \geq 1$, with centre the 0-submanifold $X = \{0\}$. Consider

$$\mathbb{R}^n \times \mathbf{P}^{n-1}(\mathbb{R})$$

where \mathbb{R}^n is endowed with usual coordinates $x = (x_1, \dots, x_n)$, while the projective space is endowed with *homogeneous* coordinates $t = (t_1, \dots, t_n)$. Set

$$\mathbf{B}(\mathbb{R}^n, 0) := \{(x, t) \in \mathbb{R}^n \times \mathbf{P}^{n-1}(\mathbb{R}); x_i t_j = x_j t_i, i, j = 1, \dots, n\}$$

this is well defined because the equations are homogeneous in the t 's. Denote by

$$\rho : \mathbf{B}(\mathbb{R}^n, 0) \rightarrow \mathbb{R}^n$$

the restriction of the projection onto \mathbb{R}^n . These objects verify several interesting properties:

(1) $\mathbf{B}(\mathbb{R}^n, 0)$ is a smooth n -manifold.

If U_j is the standard chart of the projective space with non-homogeneous coordinates $y_i = t_i/t_j$, $t_j \neq 0$, $i \neq j$, then one readily checks that $\mathbf{B}(\mathbb{R}^n, 0) \cap (\mathbb{R}^n \times U_j)$ is given as the graph of the smooth function $x_i = x_j y_i$, $i \neq j$.

(2) *The restriction*

$$\rho : \mathbf{B}(\mathbb{R}^n, 0) \setminus \rho^{-1}(0) \rightarrow \mathbb{R}^n \setminus \{0\}$$

is a diffeomorphism.

Assume that $((a_1, \dots, a_n), (y_1, \dots, y_n)) \in \mathbf{B}(\mathbb{R}^n, 0)$ with some $a_i \neq 0$. Then for every j , $y_j = (a_j/a_i)y_i$ is uniquely determined as a point of $\mathbf{P}^{n-1}(\mathbb{R})$. This also shows that

$$(a_1, \dots, a_n) \rightarrow ((a_1, \dots, a_n), (a_1, \dots, a_n)) \in \mathbf{B}(\mathbb{R}^n, 0) \setminus \rho^{-1}(0)$$

defined for $(a_1, \dots, a_n) \in \mathbb{R}^n \setminus \{0\}$ is the inverse diffeomorphism.

(3) *The inverse image*

$$\rho^{-1}(0) = \{0\} \times \mathbf{P}^{n-1}(\mathbb{R}) \sim \mathbf{P}^{n-1}(\mathbb{R})$$

and it is in natural bijection with the set of lines in \mathbb{R}^n passing through 0; hence it is the projectivization of \mathbb{R}^n considered as vector bundle over the 0-dimensional manifold $X = \{0\}$.

Every such a line L has a parametric equation $x_i = a_i t$, $i = 1, \dots, n$. Consider $L' = \rho^{-1}(L \setminus \{0\})$. L' has parametric equations $x_i = a_i t$, $t_i = a_i t$, $t \neq 0$, $i = 1, \dots, n$. As the t 's are homogeneous, equivalently L' is described by $x_i = a_i t$, $y_i = a_i$, $t \neq 0$. These equations extend to define the so called *strict transform* \tilde{L} of L in $\mathbf{B}(\mathbb{R}^n, 0)$, that is the closure of L' ; finally \tilde{L} intersects transversely $\mathbf{P}^{n-1}(\mathbb{R})$ at the point (a_1, \dots, a_n) and

$$L \rightarrow \tilde{L} \cap \mathbf{P}^{n-1}(\mathbb{R})$$

defines the required bijection (after all, it corresponds to the bijection between $x \in \mathbf{P}^{n-1}(\mathbb{R})$ and the respective fibre in the tautological bundle over $\mathbf{P}^{n-1}(\mathbb{R})$).

(4) In a more qualitative cut-and-paste fashion, $\mathbf{B}(\mathbb{R}_n, 0)$ is obtained by gluing along the boundary the closure of $\mathbb{R}^n \setminus D^n$ with $\mathbf{B}(D^n, 0)$ and this last can be identified with the *mapping cylinder* of the natural degree two covering map

$$c : S^{n-1} \rightarrow \mathbf{P}^{n-1}(\mathbb{R})$$

$$S^{n-1} = \partial D^n.$$

Consider now $\mathbb{R}^k \subset \mathbb{R}^{k+n} = \mathbb{R}^k \times \mathbb{R}^n$ (defined as usual by the equation $x_i = 0$, $i > k$). $\mathbb{R}^{k+n} = \mathbb{R}^k \times \mathbb{R}^n$ can be considered as the total space of the product vector bundle over the manifold $X = \mathbb{R}^k$, with fibre \mathbb{R}^n . Then define the *blowing up of \mathbb{R}^{k+n} with centre $X = \mathbb{R}^k$* by

$$\mathbf{B}(\mathbb{R}^{k+n}, \mathbb{R}^k) := \mathbb{R}^k \times \mathbf{B}(\mathbb{R}^n, 0)$$

endowed with the restriction of the natural projection

$$\rho = \rho_{n,k} : \mathbf{B}(\mathbb{R}^{k+n}, \mathbb{R}^k) \rightarrow \mathbb{R}^{k+n}.$$

The above properties extend directly; set

$$D_{n,k} = \rho^{-1}(\mathbb{R}^k)$$

then:

(1) The restriction

$$\rho : \mathbf{B}(\mathbb{R}^{k+n}, \mathbb{R}^k) \setminus D_{n,k} \rightarrow \mathbb{R}^{k+n} \setminus \mathbb{R}^k$$

is a diffeomorphism;

(2) $D_{n,k} = \mathbb{R}^k \times \mathbf{P}^{n-1}(\mathbb{R})$ and it is the total space of the projectivization of the above trivial vector bundle;

(3) $\mathbf{B}(D^n, \mathbb{R}^k)$ is the mapping cylinder of the natural degree two covering map

$$c : \mathbb{R}^k \times S^{n-1} \rightarrow \mathbb{R}^k \times \mathbf{P}^{n-1}(\mathbb{R})$$

and $\mathbf{B}(\mathbb{R}^{k+n}, \mathbb{R}^k)$ can be obtained by gluing $\mathbf{B}(D^n, \mathbb{R}^k)$ to the closure of $\mathbb{R}^{k+n} \setminus (\mathbb{R}^k \times D^n)$, along the boundary.

Moreover:

(4) If $\mathbb{R}^k \subset \mathbb{R}^{k+h} \subset \mathbb{R}^{k+n}$, $h < n$, then the closure in $\mathbf{B}(\mathbb{R}^{k+n}, \mathbb{R}^k)$ of $\rho^{-1}(\mathbb{R}^{k+h} \setminus \mathbb{R}^k)$ is equal to $\mathbf{B}(\mathbb{R}^{k+h}, \mathbb{R}^k)$, $\rho_{h,k}$ is the restriction of $\rho_{n,k}$, $\mathbf{B}(\mathbb{R}^{k+h}, \mathbb{R}^k)$ intersects transversely $D_{n,k}$ at $D_{h,k}$.

(5) Given $\mathbb{R}^k \times \mathbb{R}^s \times \mathbb{R}^h$, then $\mathbf{B}(\mathbb{R}^{k+s}, \mathbb{R}^k)$ and $\mathbf{B}(\mathbb{R}^{k+h}, \mathbb{R}^k)$ are disjoint submanifolds of $\mathbf{B}(\mathbb{R}^{k+s+h}, \mathbb{R}^k)$. Note that $\mathbb{R}^{k+s} \cap \mathbb{R}^{k+h} = \mathbb{R}^k \subset \mathbb{R}^{k+s+h}$, hence $\mathbb{R}^{k+s} \cup \mathbb{R}^{k+h}$ is 'singular' along \mathbb{R}^k . Blowing up with centre \mathbb{R}^k is a way to 'desingularize' it.

Let M be a compact boundaryless smooth $(k+n)$ -manifold and $X \subset M$ a proper k -submanifold. We define the *blowing up of M with centre X*

$$\rho = \rho_{M,X} : \mathbf{B}(M, X) \rightarrow M$$

as follows: recall that a tubular neighbourhood

$$\pi : U \rightarrow X$$

of X in M is by construction isomorphic to a neighbourhood fibred by n -disks of the 0-section (identified with X) of a rank k vector sub-bundle

$$p : E \rightarrow X$$

of the restriction of $T(M)$ to X , such that

$$\partial\pi : \partial U \rightarrow X$$

is isomorphic to the unitary bundle

$$up : UE \rightarrow X$$

with fibre S^{n-1} . There is a natural degree 2 covering map

$$c : UE \rightarrow \mathbf{P}(E)$$

such that $up = \mathbf{p} \circ c$. Then $\mathbf{B}(M, X)$ is obtained by gluing the mapping cylinder of this map c to the closure of $M \setminus U$, along its boundary. The above $(\mathbf{B}(\mathbb{R}^{k+n}, \mathbb{R}^k), \rho_{n,k})$ provides the local model for $(\mathbf{B}(M, X), \rho_{M,X})$, so that

- $\mathbf{B}(M, X)$ is a smooth compact $(k+n)$ -manifold as well as ρ is a smooth map;

- Denote by $D(M, X) = \rho^{-1}(X)$. Then the restriction

$$\rho : \mathbf{B}(M, X) \setminus D(M, X) \rightarrow M \setminus X$$

is a diffeomorphism;

- The restriction $\rho : D(M, X) \rightarrow X$ is isomorphic to the projectivized bundle $\mathbf{p} : \mathbf{P}(E) \rightarrow X$.

REMARK 7.27. If X is a hypersurface of M ($\dim X = \dim M - 1$), then $\rho : \mathbf{B}(M, X) \rightarrow M$ is a global diffeomorphism.

If Y is a subset of M , the *strict transform* \tilde{Y} of Y in $\mathbf{B}(M, X)$ is by definition the closure of $\rho^{-1}(Y \setminus X)$. Then we have:

- Let M be as above, $N \subset M$ a proper submanifold of M and $X \subset N$ a proper submanifold of N (whence of M). Then the strict transform \tilde{N} in $\mathbf{B}(M, X)$ is a proper submanifold diffeomorphic to $\mathbf{B}(N, X)$, moreover \tilde{N} intersects transversely $D(M, X)$ at $D(N, X)$.

- If N and N' are proper submanifolds of M which intersect transversely at $X = N \cap N' \neq \emptyset$, then the strict transforms \tilde{N} and \tilde{N}' are disjoint in $\mathbf{B}(M, X)$. Note that $N \cup N'$ is not a submanifold of M because it is ‘singular’ along X . So by blowing up the singularity and taking the strict transforms we can ‘desingularize’ it.

When $X = \{x_0\} \subset M$ is reduced to one point, blowing up X is related to the connected sum. We have

PROPOSITION 7.28. (1) If $\dim M = m$ is even, then $\mathbf{B}(M, x_0) \sim M \# \mathbf{P}^m(\mathbb{R})$ (recall that $\mathbf{P}^m(\mathbb{R})$ is not orientable).

(2) If M is oriented and $\dim M = m$ is odd, then:

(a) $\mathbf{B}(M, x_0)$ is oriented in such a way that the restriction

$$\rho : \mathbf{B}(M, x_0) \setminus D(M, x_0) \rightarrow M \setminus \{x_0\}$$

preserves the orientation;

(b) Let us stipulate that S^m is oriented as the boundary of D^{m+1} oriented by the standard orientation of \mathbb{R}^n , and that $\mathbf{P}^m(\mathbb{R})$ is oriented in such a way that the standard covering map $S^m \rightarrow \mathbf{P}^m(\mathbb{R})$ preserves the orientation; then

$$\mathbf{B}(M, x_0) \sim M \# -\mathbf{P}^m(\mathbb{R})$$

where ‘ $-$ ’ indicates the opposite orientation and we are dealing with the oriented connected sum.

Proof : Forget for a while orientation questions. By taking a chart $\sim \mathbb{R}^m$ of M at $x_0 \sim 0$, we can assume that D^m is a tubular neighbourhood of x_0 . Recall that $\mathbf{B}(D^m, 0) \subset \mathbb{R}^m \times \mathbf{P}^{m-1}$, this last endowed with ‘mixed’ coordinates (x, t) . Let $z = (z_1, \dots, z_{m+1})$ be homogeneous coordinates on $\mathbf{P}^m(\mathbb{R})$, take the standard affine chart $U = \{t_{m+1} \neq 0\}$; $U \sim \mathbb{R}^m$, with coordinate $y_1 = (z_1/z_{m+1}, \dots, y_m = z_m/z_{m+1})$. Then it is enough to prove that there is a diffeomorphism

$$\phi : \mathbf{B}(D^m, 0) \rightarrow \overline{\mathbf{P}^m(\mathbb{R})} \setminus D^m$$

which is the identity on ∂D^m . The diffeomorphism ϕ can be defined explicitly as follows:

$$\phi(x_1, \dots, x_m, t_1, \dots, t_m) = (t_1, \dots, t_m, t(\sum_{j=1}^m x_j^2)) \in \mathbf{P}^m(\mathbb{R})$$

where $t = t_i/z_i$ if $z_i \neq 0$, $i = 1, \dots, m$. The verifications that ϕ is well defined, its image is $\overline{\mathbf{P}^m(\mathbb{R})} \setminus D^m$ and that it is a diffeomorphism are left as an exercise. Coming back to the orientation question: if m is even then $\mathbf{P}^m(\mathbb{R})$ is non orientable, hence the connected sum with it is well defined. In the oriented case we easily check that $\mathbf{B}(D^m, 0)$ and $\overline{\mathbf{P}^m(\mathbb{R})} \setminus D^m$ induce opposite orientations on the common boundary ∂D^m . Hence the diffeomorphism ϕ reverses the orientation and (b) follows. \square

7.10.2. On complex blowing up. The (complex) blowing up $\mathbf{B}_{\mathbb{C}}(M, X)$ can be performed in the category of complex manifolds as well. At least the basic $\mathbf{B}_{\mathbb{C}}(\mathbb{C}^n, 0)$ is defined by the very same formulas of $\mathbf{B}(\mathbb{R}^n, 0)$, in terms of complex coordinates. Hence we can define the blowing up $\mathbf{B}_{\mathbb{C}}(M, x_0)$ of a complex manifold at a point x_0 . More generally, if M is an *oriented* $2n$ -smooth manifold, $x_0 \in M$ we can define $\mathbf{B}_{\mathbb{C}}(M, x_0)$ (up to oriented diffeomorphism) by taking an oriented chart $\mathbb{R}^{2n} \sim \mathbb{C}^n$ at $x_0 \sim 0$, perform $\mathbf{B}_{\mathbb{C}}(D^{2n}, 0)$ and glue it to $M \setminus D^{2n}$. We have

PROPOSITION 7.29. *Let M be a compact oriented $2n$ -manifold, $x_0 \in M$. Then $\mathbf{B}_{\mathbb{C}}(M, x_0) \sim M \# -\mathbf{P}^n(\mathbb{C})$.*

Proof : As in the proof of Proposition 7.28, the key point is to construct a suitable diffeomorphism

$$\phi_{\mathbb{C}} : \mathbf{B}_{\mathbb{C}}(D^{2n}, 0) \rightarrow \overline{\mathbf{P}^n(\mathbb{C})} \setminus D^{2n} .$$

In fact the formula that defines ϕ above works as well, provided that it is considered in terms of the complex coordinates and we replace each x_j^2 with $|x_j|^2$. \square

REMARK 7.30. Blowing up works in the category of (real or complex) regular algebraic varieties. In fact algebraic geometry is the first source of this construction and we have just developed a smooth version. Note that in the algebraic setting, $\mathbf{B}(M, X) \setminus D(M, X)$ is a Zariski open set of the regular algebraic variety $\mathbf{B}(M, X)$ as well as $M \setminus X$ is a Zariski open set of the regular algebraic variety M ; the restriction of ρ is an algebraic isomorphism between these Zariski open sets, hence (essentially by definition) M and $\mathbf{B}(M, X)$ are *birationally equivalent*. M is said to be *rational* if it is birationally equivalent to the projective space of the same dimension. Blowing up a projective space along regular centres is a basic way to construct rational varieties.

Transversality

We have already employed some instances of transversality and related concepts. Here we will treat this topic more systematically. First we point out so called “basic transversality theorems” which to a large extent will suffice to our aims. Then we will develop some complements.

8.1. Basic transversality

We consider the following setting.

- M is a smooth m -manifold with (possibly empty) boundary ∂M ;
- N is a smooth boundaryless n -manifold and $Z \subset N$ is a proper r -submanifold of N , hence Z is both boundaryless and a closed subset of N ;
- $f : M \rightarrow N$ is a smooth map. If the boundary is non empty, then ∂f denotes the restriction of f to ∂M .

DEFINITION 8.1. We say that f is *transverse to Z* (and we write $f \pitchfork Z$) if

- (1) For every $x \in M$ such that $y = f(x) \in Z$, we have

$$T_y N = T_y Z + d_x f(T_x M) .$$

- (2) For every $x \in \partial M$ such that $\partial f(x) \in Z$, we have

$$T_y N = T_y Z + d_x \partial f(T_x \partial M) ,$$

in other words, $\partial f \pitchfork Z$ by itself. Obviously, if $\partial M = \emptyset$, then this second requirement is empty.

We denote by $\pitchfork(M, N; Z)$ the subspace of $\mathcal{E}(M, N)$ formed by the maps transverse to Z . If A is a subset of M we denote by $\pitchfork_A(M, N; Z)$ the space of maps which verify the transversality conditions for every $x \in A$ or $x \in A \cap \partial M$, so that $\pitchfork(M, N; Z) = \pitchfork_M(M, N; Z)$.

Some particular cases:

- If $f(M) \cap Z = \emptyset$, then $f \pitchfork Z$;
- If $Z = \{y_0\}$ a single point then $f \pitchfork Z$ if and only if y_0 is a regular value of both f and ∂f .
- If also M is a boundaryless submanifold of N and f is the inclusion, then $f \pitchfork Z$ (and we write also $M \pitchfork Z$) if and only if for every $x \in M \cap Z$, $T_x N = T_x M + T_x Z$; if $\dim M + \dim Z = \dim N$, then $T_x N = T_x M \oplus T_x Z$.
- The basic local models for $M \pitchfork Z$, and in fact for the whole transversality stuff, is given by the possible mutual position of two affine subspaces, say A and B , in some \mathbb{R}^n . If $\dim A + \dim B < n$, then $A \pitchfork B$ if and only if $A \cap B = \emptyset$. If $A \cap B \neq \emptyset$, up to translation we can assume that they are linear subspaces which are transverse if and only if $\mathbb{R}^n = A + B$. Note that $A \cap B$ is also a linear subspace and, by elementary linear algebra $\dim A \cap B = \dim A + \dim B - n \geq 0$.

There are two kinds of basic transversality theorems; roughly speaking, they respectively claim that transversality implies nice geometric features of the map f , and that (at least when M is compact) it is a *generic and stable* property: up to

arbitrarily small perturbation every map f becomes transverse, and transversality cannot be destroyed by small perturbations.

In the given setting we have:

THEOREM 8.2. (First basic transversality theorem) *(1) If $f : M \rightarrow N$ is transverse to Z , then $(Y, \partial Y) := (f^{-1}(Z), \partial f^{-1}(Z))$ is a proper submanifold of $(M, \partial M)$; moreover $\dim M - \dim Y = \dim N - \dim Z$.*

(2) If $(M, \partial M)$, N and Z are oriented then Y and ∂Y are orientable and we can fix an orientation procedure in such a way that ∂Y is the oriented boundary of Y .

Proof : When $Z = \{y_0\}$ consists of one points, then the theorem is equivalent to Proposition 2.25. Let us reduce the general to this special case. As Z is a closed subset then also $f^{-1}(Z)$ and $\partial f^{-1}(Z)$ are closed sets. Being a proper submanifold is a local property. For every $z \in Z$ there is a chart of N , $\phi : W \rightarrow U \times U' \subset \mathbb{R}^r \times \mathbb{R}^{n-r}$, such that $\phi(z) = 0 \in U \times U'$, and $\phi(W \cap Z) = U \times \{0\}$. Let $p : U \times U' \rightarrow U'$ be the projection. Then it is easy to see that the restriction of f to $f^{-1}(W)$ is transverse to Z if and only if $p \circ \phi \circ f$ is transverse to $\{0\}$. This is enough to achieve point (1). As for the orientation, let us orient \mathbb{R}^{n-r} in such a way that the given orientation of \mathbb{R}^n (i.e. of N) is the direct sum of the given orientation of \mathbb{R}^r (i.e. of Z) followed the selected one on \mathbb{R}^{n-r} . Then we can apply to $p \circ \phi \circ f$ the orientation rule of point (2) of Proposition 2.25 to orient the intersection of $(Y, \partial Y)$ with W ; by construction these local orientations are globally coherent. \square

REMARK 8.3. It is useful to make explicit the orientation rule in the case of transverse intersection $M \pitchfork Z$ of submanifolds of N . For every $x \in M \cap Z$, $T_x N = T_x M + T_x Z$, and by assumption the linear spaces $T_x N$, $T_x M$ and $T_x Z$ are oriented (in a globally coherent way) and the last two intersect transversely in the first. We have to orient $T_x M \cap T_x Z$. So we have reduced the problem to the basic situation of two transverse oriented linear subspaces (A, ω_A) and (B, ω_B) in \mathbb{R}^n (endowed say with the standard orientation ω_n). Given any orientation $\omega_{A \cap B}$ on the intersection, it can be extended in a unique way to A and B in such a way that $\omega_A = \omega_{A \cap B} \oplus \omega'$ and $\omega_B = \omega_{A \cap B} \oplus \omega''$. Then $\omega_{A \cap B} \oplus \omega' \oplus \omega''$ determines an orientation on the whole \mathbb{R}^n . Finally we select the orientation $\omega_{A \pitchfork B}$ such that the orientation of \mathbb{R}^n obtained so far coincides with the given ω_n . Note that in the non oriented setting $M \pitchfork Z = Z \pitchfork M$, but the orientation depends on the order; this can be checked straightforwardly in the linear local model; we get

$$M \pitchfork Z = (-1)^{(\dim N - \dim M)(\dim N - \dim Z)} Z \pitchfork M .$$

A very important consequence of Theorem 8.2 is the following *parametric transversality theorem*. In a sense it represents the bridge between the two kinds of transversality theorems. Keeping the above setting, consider furthermore a boundaryless “parameter” smooth manifold S , so that $M \times S$ has boundary equal to $\partial M \times S$. We have

THEOREM 8.4. *Let $F : M \times S \rightarrow N$ be transverse to Z . For every $s \in S$, set $f_s : M \rightarrow N$ the restriction of F to $M \sim M \times \{s\}$. Then the set of parameters $s \in S$ such that f_s is not transverse to Z is negligible in S .*

Proof : Let $(Y, \partial Y) = (F^{-1}(Z), \partial F^{-1}(Z))$ be the proper submanifold of $(M \times S, \partial M \times S)$ accordingly with Theorem 8.2. Set $\pi : Y \rightarrow S$ the restriction to Y of the projection $p : M \times S \rightarrow S$. We claim that for every regular value s of both π and $\partial \pi$ (i.e. such that $\pi \pitchfork \{s\}$), then f_s is transverse to Z . The thesis will follow from the Sard-Brown theorem. Let us justify the claim. Let $x \in M$ be

such that $f_s(x) = F(x, s) = z \in Z$. As $F \pitchfork Z$, for every $w \in T_z N$, there are $(u, v) \in T_x M \times T_s S$ and $t \in T_z Z$ such that

$$w = d_{(x,s)}F(u, v) + t .$$

The differential

$$d_{(x,s)}p : T_x M \times T_s S \rightarrow T_s S$$

is just the projection onto the second factor, and $d_{(x,s)}\pi$ is obtained by restriction. As s is a regular value of π , then there exists a vector of the form $(u', v) \in T_{(x,s)}Y$. By definition of Y , $t' := d_{(x,s)}F(u', v) \in T_z Z$. Finally we readily verify that

$$w = d_{(x,s)}F(u - u', 0) + d_{(x,s)}F(u', v) + t = d_x f_s(u - u') + (t' - t) .$$

This proves that $T_z N = d_x f_s(T_x M) + T_z Z$. By using that s is also a regular value of $\partial\pi$, the very same argument shows that $\partial f_s \pitchfork Z$. This achieves the proof. \square

To state the second transversality theorem, we refine the setting. That is we assume furthermore that

- (1) M is compact;
- (2) N can be embedded in some \mathbb{R}^h being also a closed subset.

In many application also N and Z will be compact. In any case these assumptions allows to apply to N the results of Section 5.12.1. In this refined setting we have:

THEOREM 8.5. (Second basic transversality theorem) *(1) The set $\pitchfork(M, N; Z)$ of smooth maps transverse to Z is open and dense in $\mathcal{E}(M, N)$.*

(2) Let $f \in \mathcal{E}(M, N)$ be such that $\partial f : \partial M \rightarrow N$ is transverse to Z . Denote by $\mathcal{E}(M, N, \partial f)$ (resp. $\pitchfork(M, N, \partial f; Z)$) the space of smooth maps that coincide with ∂f on ∂M (and are transverse to Z). Then $\pitchfork(M, N, \partial f; Z)$ is open dense in $\mathcal{E}(M, N, \partial f)$.

(3) For every $h \in \mathcal{E}(M, N)$ (resp. $h \in \mathcal{E}(M, N, \partial f)$) there is $g \in \pitchfork(M, N; Z)$ ($g \in \pitchfork(M, N, \partial f; Z)$) smoothly homotopic to h .

Proof : Let us consider first the openness in both items (1) and (2). As M is compact, in early chapters we have already achieved it in the case of summersions; this easily implies the Theorem when $Z = \{y_0\}$ consists of one point. By using the local reduction argument to this case as in the proof of Theorem 8.2, for every $f \in \pitchfork(M, N; Z)$, we can find a finite covering of M by compact sets K such that f reduces to the special case on a neighbourhood of each K in M . Then, for every K , there is a open neighbourhood \mathcal{U}_K of f in $\mathcal{E}(M, N)$ formed by maps which verify the transversality conditions at every $x \in K$. Then the intersection of these finite family of open sets \mathcal{U}_K is a open neighbourhood of f in $\mathcal{E}(M, N)$ contained in $\pitchfork(M, N; Z)$; hence it is open. The same argument applies to $\pitchfork(M, N, \partial f; Z)$.

Let us come now to the density stated in (1). We consider first the special case when $N = \mathbb{R}^n = \mathbb{R}^r \times \mathbb{R}^{n-r}$ and $Z = \mathbb{R}^r = \mathbb{R}^r \times \{0\}$. Let $f \in \mathcal{E}(M, \mathbb{R}^n)$. Then clearly the map

$$F : M \times \mathbb{R}^n \rightarrow \mathbb{R}^n, F(x, s) = f(x) + s$$

is transverse to \mathbb{R}^r (in fact it is a summersion onto the whole \mathbb{R}^n) and we can apply to it the parametric transversality Theorem 8.4. Then for every $\epsilon > 0$ there is $s \in \mathbb{R}^n$ such that $\|s\| < \epsilon$ and $f_s \pitchfork Z$. As M is compact, by taking ϵ small enough, then $f_s = f + s$ can be arbitrarily close to f in the C^∞ -topology.

We are going to apply the same argument in the general case, by means of a more elabotare construction. Let $f \in \mathcal{E}(M, N)$. For the moment assume for simplicity that $N \subset \mathbb{R}^h$ is compact and take a tubular neighbourhood $\pi_N : U_N \rightarrow N$ of N

in \mathbb{R}^h constructed by means of the standard riemannian metric g_0 on \mathbb{R}^h and some $\epsilon_0 > 0$. Consider the restriction of the map defined above

$$F : M \times B^h(0, \epsilon) \rightarrow \mathbb{R}^h, \quad F(x, s) = f(x) + s .$$

The parameter space is now restricted to the open ball of ray ϵ ; as M and N are compact, then if ϵ is small enough, the image of F is contained in U_N and we can define

$$\hat{F} : M \times B^h(0, \epsilon) \rightarrow N, \quad \hat{F}(x, s) = \pi_N(F(x, s)) .$$

As both F and π_N are summersions, also \hat{F} is a summersion, hence $\hat{F} \pitchfork Z$, and we can apply again Theorem 8.4. For s generic and small enough, $\hat{f}_s \pitchfork Z$ and is arbitrarily close to f . If N is not compact, by using the considerations of Section 5.12.1, there is a compact submanifold with boundary $N' \subset N$ such that $f(M) \subset \text{Int}(N')$ and we can repeat the above argument by using a tubular “neighbourhood” $\pi_{N'} : U_{N'} \rightarrow N'$. Alternatively, we can use (instead of π_N) the projection $\pi : N_\epsilon \rightarrow N$ defined on the ϵ -neighbourhood of N determined by a suitable smooth positive function $\epsilon : N \rightarrow \mathbb{R}$, and the modified maps

$$\hat{F} : M \times B^h(0, 1) \rightarrow N, \quad \hat{F}(x, s) = \pi(f(x) + \epsilon(x)s) .$$

Let us face now the density stated in (2). We follow the same scheme, by suitably modifying the map \hat{F} . Let $f \in \mathcal{E}(M, N)$ be such that $\partial f \pitchfork Z$. By using the same consideration developed to prove the openness, it is easy to verify that $f \pitchfork Z$ provided that it is restricted to a small collar C of ∂M . By slightly modifying the construction of a collar bump function, we can construct a smooth function $\gamma : M \rightarrow [0, 1]$ such that γ is constantly equal to 0 on a smaller closed collar $C' \subset C$, γ is positive on the complement of C' and constantly equal to 1 outside C . Again assume for simplicity that $N \subset \mathbb{R}^h$ is compact and let $\pi_N : U_N \rightarrow N$ as above. Then define

$$\hat{F} : M \times B^h(0, \epsilon) \rightarrow N, \quad \hat{F}(x, s) = \pi_N(f(x) + \gamma^2(x)s) .$$

We claim that $\hat{F} \pitchfork Z$, then for generic s small enough, $\hat{f}_s = \pi_N \circ (f + \gamma^2 s)$ belongs to $\pitchfork (M, N, \partial f; Z)$ and is arbitrarily close to f . We can complete the discussion to N non compact as above. It remains to justify that $\hat{F} \pitchfork Z$. The restriction of \hat{F} to $\{x; \gamma^2(x) \neq 0\} \times B^h(0, \epsilon)$ is a summersion because for every fixed x , $s \rightarrow \gamma^2(x)s$ is a diffeomorphism onto its image, the map $F(x, t) = \pi_N(f(x) + t)$ is a summersion, and \hat{F} is obtained by composition. It follows that if $\hat{F}(x, s) = z \in Z$ and $\gamma^2(x) \neq 0$, then the transversality conditions are verified at (x, s) . Assume now that $\hat{F}(x, s) = z \in Z$ and $\gamma^2(x) = 0$, that is $x \in C'$. We note that $d_x \gamma^2 = 2\gamma(x)d_x \gamma$, hence it vanishes on C' . By using this fact it is not hard to verify that for every $(u, v) \in T_x(M) \times T_s B^h(0, \epsilon)$,

$$d_{(x,s)} \hat{F}(u, v) = d_x f(u)$$

hence these differentials have the same image in $T_z N$. As f restricted to C' is transverse to Z , then also the restriction of \hat{F} to C' is transverse to Z .

Concerning point (3), referring for instance to $f \in \mathcal{E}(M, N)$ and to the above proof of the density, we note that $f = \hat{f}_0$, and it is homotopic to $\hat{f}_s \pitchfork Z$ via the path $\hat{f}_{\sigma(t)}$, $\sigma(t) = (1-t)s$, $t \in [0, 1]$. On the other hand, we know in general that if g is close enough to f , then they are homotopic (recall Lemma 5.16).

The proof is now complete. □

REMARK 8.6. The proof of the openness does not use that N is embedded. We sketch here an “abstract” (similar) proof of the density of (1) and (2) in Theorem 8.5 too. For simplicity we consider statement (1) and assume that M is boundaryless

(we left to the reader the task to adapt the discussion to the other situations). Let $f \in \mathcal{E}(M, N)$. By compactness of M there is a nice atlas \mathcal{N} of M

$$\{\phi_j : W_j \rightarrow B^m(0, 1)\}_{j=1, \dots, s}$$

and a family \mathcal{F} of charts of (N, Z) of the form

$$\{\alpha_j : (V_j, Z \cap V_j) \rightarrow (\mathbb{R}^a \times \mathbb{R}^{n-r}, \mathbb{R}^a)\}$$

such that for every j , $f(W_j) \subset V_j$ so that we have the family

$$\{f_j : U_j \rightarrow \mathbb{R}^r \times \mathbb{R}^{n-r}\}$$

of associated representations of f in local coordinates supported by $(\mathcal{N}, \mathcal{F})$. Recall that every $K_j = \overline{B}_j \subset W_j$ is compact and this provides a finite compact covering of M . The subset $A_{\mathcal{N}, \mathcal{F}}$ of $\mathcal{E}(M, N)$ formed by the maps admitting local representations supported by $(\mathcal{N}, \mathcal{F})$ is open and non empty as it contains f . By applying to every $\mathcal{E}(W_j, V_j)$ the special case of the density considered in the proof of Theorem 8.5 (1) and by using the bump function γ_j in order to extend locally defined maps to maps in $\mathcal{E}(M, N)$, we realize that for every j , $\mathfrak{h}_{K_j}(M, N; Z) \cap A_{\mathcal{N}, \mathcal{F}}$ is dense in $A_{\mathcal{N}, \mathcal{F}}$. We know that it is also open. Then the intersection of these finite family of open and dense sets is open and dense in $A_{\mathcal{N}, \mathcal{F}}$, and is contained in $\mathfrak{h}(M, N; Z)$ because the K_j cover the whole of M . □

REMARK 8.7. The meaning of the transversality theorems has been precised. We have already recalled that for example *any* compact subset $K \subset B^m(0, 1)$ can be realized as $K = f^{-1}(0)$ for some smooth function $f : \overline{B}^m(0, 1) \rightarrow \mathbb{R}$; compared with the tame behaviour of K when $f \mathfrak{h} \{0\}$, this shows that non transverse situations can be really weird. On the other hand, by Theorem 8.5 remarkably any weird non transversal situation can be made stably tame up to arbitrarily small perturbations (at least when M is compact).

8.2. Miscellaneous transversalities

Transversality is a profound, potent and pervasive paradigm beyond the basic results stated in the previous section. Without any pretention of completeness we collect here a few instances of further applications.

8.2.1. Jet trasversality. First we perform some constructions within the smooth category of open sets considered in Chapter 1. In particular, we refer to the Taylor polynomials defined in Section 1.2. Recall that a *homogeneous polynomial maps of degree $k \geq 1$*

$$\mathbf{p} : \mathbb{R}^m \rightarrow \mathbb{R}^n$$

is of the form $\mathbf{p}(x) = \phi(x, \dots, x)$, where $\phi : (\mathbb{R}^m)^k \rightarrow \mathbb{R}^n$ is a (necessarily unique) *symmetric k -linear map*. The set $\mathcal{P}_k(m, n)$ of these homogeneous polynomial maps has a natural structure of finite dimensional real vector space endowed with a standard basis so that it is identified with $\mathbb{R}^{\dim \mathcal{P}_k(m, n)}$. A *polynomial map of degree $\leq r$* , $p : \mathbb{R}^m \rightarrow \mathbb{R}^n$, is of the form

$$p = p_0 + p_1 + \dots + p_r$$

where $p_0 \in \mathbb{R}^n$ and for $k \geq 1$, p_k is homogeneous polynomial map of degree k . Denote by $J^r(m, n)$ the set of these polynomial maps. We can use the natural identification

$$J^r(m, n) = \prod_{k=0}^r \mathcal{P}^k(m, n)$$

to give it a finite dimensional real vector space structure and $J^r(m, n)$ is identified with $\mathbb{R}^{\dim J^r(m, n)}$.

REMARK 8.8. With some effort one can compute the dimension:

$$\dim J^r(m, n) = n \binom{r+m}{n}.$$

Let $U \subset \mathbb{R}^m$, $V \subset \mathbb{R}^n$ be non empty open sets. Then we can define the open set of $\mathbb{R}^m \times J^r(m, n)$ by

$$J^r(U, V) := \{(x, p) \in U \times J^r(m, n); p_0 \in V\}.$$

Given a smooth map $f : U \rightarrow V$, define the smooth map

$$j^r f : U \rightarrow J^r(U, V), \quad j^r f(x) = \mathcal{T}_r f(x)$$

sending every point of U to the Taylor polynomial of f at x of degree $\leq r$.

(Composition rule) Let $U \subset \mathbb{R}^m$, $V \subset \mathbb{R}^n$ and $W \subset \mathbb{R}^h$ be non empty open sets. Set

$$J^r(U, V, W) = \{((y, q), (x, p)) \in J^r(V, W) \times J^r(U, V); p_0 = y\}.$$

Let $f : U \rightarrow V$, $g : V \rightarrow W$ be smooth maps. By a suitable extension to higher order derivatives of the chain rule, one can find an unique polynomial map (the explicit expression is called *Faa di Bruno formula*)

$$\mathfrak{P}^r : J^r(U, V, W) \rightarrow J^r(U, W)$$

such that

$$j^r(g \circ f)(x) = \mathfrak{P}^r(j^r g(y), j^r f(x)).$$

As a particular application of the composition rule we have:

(Change of coordinates) Let $U, U' \subset \mathbb{R}^m$, $V, V' \subset \mathbb{R}^n$ be non empty open sets; $\phi : U \rightarrow U'$, $\psi : V \rightarrow V'$ be diffeomorphisms. Then for every r , there is a unique smooth diffeomorphism

$$j_{\psi, \phi}^r : J^r(U, V) \rightarrow J^r(U', V')$$

such that

$$j_{\psi, \phi}^r(j^r f(x)) = j^r f'(x')$$

where

$$x' = \phi(x), \quad f' = \psi \circ f \circ \phi^{-1}.$$

Now we can globalize the above local considerations, extending what we have done for the (co)-tangent map.

Let M, N be smooth manifolds of dimension m and n respectively. Define on $M \times \mathcal{C}^\infty(M, N)$ the following relation:

$(x, f) \sim_r (x', f')$ if $x = x'$, $f(x) = f'(x)$ and there are *compatible representations in local coordinates* of f and f' at $x = x'$, $y = f(x)$, that is defined on the same charts of M and N respectively:

$$f_{U,V}, f'_{U,V} : U \rightarrow V, \quad U \subset \mathbb{R}^m, \quad V \subset \mathbb{R}^n$$

such that

$$j^r f_{U,V}(x) = j^r f'_{U,V}(x).$$

By using the change of coordinates rule, it is easy to check that this defines an equivalence relation and that if $(x, f) \sim_r (x', f')$, then the above defining property holds *for every* pair of compatible representations in local coordinates. We denote the equivalence class of (x, f) by $j^r f(x)$ and it is called the *r-jet* of f at x , $J^r(M, N)$ is the *space of r-jets* from M to N . For every smooth map $f : M \rightarrow N$, the map

$$j^r f : M \rightarrow J^r(M, N)$$

is called the r -jet extension of f . Clearly $J^0(M, N) = M \times N$. For every $r \geq 1$, $J^r(M, N)$ has a natural structure of smooth manifold of dimension

$$\dim J^r(M, N) = \dim M + \dim J^r(m, n) .$$

Local coordinates U and V for M and N carry local coordinates $J^r(U, V)$ for $J^r(M, N)$. This provides a smooth atlas of $J^r(M, N)$ and we have already settled the change of coordinates rules. We see above also the local representations of an extension $j^r f$, which is a smooth map indeed. There is a natural smooth projection

$$\sigma_r : J^r(M, N) \rightarrow M$$

and a sequence of smooth “forgetting” maps which factorize σ :

$$M \leftarrow J^1(M, N) \leftarrow \cdots \leftarrow J^r(M, N) .$$

The map σ_r is a smooth fibration with fibre *diffeomorphic* to $J^r(m, n)$; note that in spite of the fact that $J^r(m, n)$ is a vector space with a preferred basis, for $r > 1$ σ_r is *not* a vector bundle. The atlas of $J^r(M, N)$ is fibred but the changes of coordinates do not preserve the linear structure of the fibre. Every jet extension $j^r f : M \rightarrow J^r(M, N)$ is a section of such smooth fibre bundle. Also every map $J^s(M, N) \rightarrow J^{s-1}(M, N)$ is a smooth fibration with fibre $\mathcal{P}^s(m, n)$.

We are ready to state a version of the so called *jet transversality theorem*. Let M and N be smooth boundaryless manifolds and Z be a submanifold of $J^r(M, N)$. Denote by

$$\pitchfork j^r(M, N, Z)$$

the set of smooth map $f \in \mathcal{E}(M, N)$ such that $j^r f \pitchfork Z$. We have:

THEOREM 8.9. *Let M be a compact smooth boundaryless manifold and N be a boundaryless proper smooth submanifold of some \mathbb{R}^h . Let Z be a proper submanifold of $J^r(M, N)$. Then $\pitchfork j^r(M, N, Z)$ is open and dense in $\mathcal{E}(M, N)$.*

Proof : We limit to an outline. Note that also $J^r(M, N)$ can be embedded as a proper submanifold of some \mathbb{R}^k . When $r = 0$, Theorem 8.9 incorporates (1) of Theorem 8.5 (at least when M is boundaryless). Openness is not hard. As for the density, Theorem 8.5 ensures that every $j^r f$ can be approximated by a smooth map $g : M \rightarrow J^r(M, N)$ transverse to Z , but the statement of theorem 8.9 requires furthermore that g is the r -jet extension of some map $\tilde{f} : M \rightarrow N$. So jet-transversality is not an immediate consequence of standard transversality. Nevertheless the structure of the proofs is basically the same. A first, fundamental case to deal with is when $N = \mathbb{R}^n$. In the proof of Theorem 8.5 the key point was the application of parametric transversality to the deformations of a given map $f : M \rightarrow \mathbb{R}^n$ of the form $f + s$, $s \in \mathbb{R}^n$. In the present situation the main difference consists in using polynomial deformations of the form $f + p_0 + p_1 + \cdots + p_r$, where $p = p_0 + \cdots + p_r$ varies among the polynomial maps $p : \mathbb{R}^n \rightarrow \mathbb{R}^n$ of degree $\leq r$. Provided this new ingredient, the proof theorem 8.5 can be repeated with minor changes. □

8.2.2. Transversality to stratifications. In several situations it is convenient to extend the notion of “general position” (i.e. of transversality) with respect to suitable “stratification” either of N for the standard transversality or of $J^r(M, N)$ for jet-transversality. We do not intend to present here a consistent treatment of stratification theory. We limit to a few suggestion. At a first sight a stratification of a smooth manifold X is a partition $\mathcal{S} = \{S_j\}$ by means of boundaryless, connected *not necessarily proper* smooth submanifolds of X , called the *strata* of the stratification. In fact one usually requires more; reasonable requirements are:

- The stratification is locally finite;

- (*Frontier condition*) The frontier $\bar{S}_j \setminus S_j$ of every stratum S_j is union of strata of strictly lower dimension;
- For every $0 \leq s \leq \dim X$, denote by X^s the *s-skeleton* of the stratification that is the union of strata of dimension less or equal to s . Then X^s is a closed subset of X .

For example if $S \subset X$ is a boundaryless proper submanifold, then $\{X \setminus S, S\}$ is a stratification of X ; the open simplices of a smooth triangulation of X as it is described in Section 14.9 form a stratification; in this case every stratum of dimension geater or equal to 1 is not a proper submanifold.

Given a stratification \mathcal{S} of N , denote by $\mathfrak{h}(M, N, \mathcal{S})$ the subspace of $\mathcal{E}(M, N)$ formed by the map $f : M \rightarrow N$ wich are transverse to every stratum of \mathcal{S} (we write $f \mathfrak{h} \mathcal{S}$). Similarly, for every $r \geq 1$, given a stratification \mathcal{S} of $J^r(M, N)$ we define $\mathfrak{h} j^r(M, N, \mathcal{S})$.

(*Nice stratifications*) We define this notion in a quite implicit way. Assume N satisfies the hypotheses of Theorem 8.9. We say that a stratification \mathcal{S} as above is *nice* if for every compact boundaryless smooth manifold M , $\mathfrak{h}(M, N, \mathcal{S})$ (resp. $\mathfrak{h} j^r(M, N, \mathcal{S})$) is *open and dense* in $\mathcal{E}(M, N)$ and, moreover, for every such a map f transverse to \mathcal{S} , $f^{-1}(\mathcal{S})$ (resp. $j^r f^{-1}(\mathcal{S})$) is a nice stratification of M .

A key question is to determine further explicit (as mild as possible) conditions in order that a stratification \mathcal{S} is nice. Roughly speaking such conditions should imply that the transversality to any stratum S_j forces at least locally at S_j the transversality to every stratum S_i such that S_j is in the frontier of S_i . We will not face this rather deep question (see also [Wall2]). We limit to state some results where the stratifications are nice, without justifying this fact.

8.2.3. A classification of map singularities. An important field of application of jet-transversality (in the stratified extension) is the study of *singularities of smooth maps* (see [A2]). The idea is that, under suitable hypotheses, for a “generic” map $f : M \rightarrow N$, the source manifold M carries a nice stratification such that the increasing codimension of the strata corresponds to more and more ‘deep’ classes of singular points of f determined by a certain specific *lack of transversality*. Moreover, the occurrence of such singular points cannot be eliminated by means of small perturbations of the map.

(*Classification by the differential rank*) A first coarse classification is in term of the rank of differentials. Let M and N be boundaryless manifolds. Let $f : M \rightarrow N$ be a smooth map. A point $x \in M$ is said of *class* Σ^i (*with respect to* f) if $\dim \ker d_x f = i$. For every i , denote by $\Sigma^i(f)$ the subset of M of points of class Σ^i . They form a partition of M . If f is arbitrary this partition might be weird. However we have:

PROPOSITION 8.10. *Let M and N verify the hypotheses of Theorem 8.9. Then there is an open dense set \mathcal{R} in $\mathcal{E}(M, N)$ such that for every $f \in \mathcal{R}$, the connected components of the $\Sigma^i(f)$ ’s form a nice stratification of M . Moreover, every $\Sigma^i(f)$ is a submanifold of M of dimension given by*

$$\dim M - \dim \Sigma^i(f) = (\dim M - r)(\dim N - r), \quad r = \dim M - i .$$

In fact one defines a suitable nice stratification \mathcal{S}_Σ of $J^1(M, N)$ and for every generic f we consider $\mathcal{R} = (j^1 f)^{-1}(\mathcal{S}_\Sigma)$. In local coordinates $J^1(U, V)$, \mathcal{S}_Σ corresponds to the stratification of the matrix space $M(n, m, \mathbb{R})$ by the matrix rank. \square

EXAMPLE 8.11. (1) If $N = \mathbb{R}$, then $J^1(M, \mathbb{R})$ is naturally identified with the cotangent bundle and $df = j^1 f$; f is a Morse function if and only if $j^1 f$ is transverse to the zero section of the bundle. Hence the result about Morse function (at least

when M is compact boundaryless) of Chapter 5 can be reobtained as a special case of jet-transversality.

(2) (*Whitney fold*) Consider the map $f : \mathbb{R}^2 \rightarrow \mathbb{R}^2$ defined by

$$f(x_1, x_2) = (x_1^3 + x_1x_2, x_2) .$$

The set of singular points is the parabole $S := \{3x_1^2 + x_2 = 0\}$. The nice stratification of the source \mathbb{R}^2 is given by $\Sigma^0(f) = \mathbb{R}^2 \setminus S$, $\Sigma^1(f) = S$.

(3) (*Whitney umbrella*) See also Section 7.8 . Consider the map $f : \mathbb{R}^2 \rightarrow \mathbb{R}^3$ defined by

$$f(x_1, x_2) = (x_1x_2, x_2, x_1^2) .$$

The point $0 \in \mathbb{R}^2$ is the only one at which f is not an immersion; hence the nice stratification of \mathbb{R}^2 is given by $\Sigma^0(f) = \mathbb{R}^2 \setminus \{0\}$, $\Sigma^1(f) = \{0\}$.

The above examples show that the stratification by the differential rank is in general too coarse. In the Whitney fold, $0 \in \Sigma^1(f) = S$ is clearly special: $\ker d_0f = T_0S$ while for other $x \in S$, $\mathbb{R}^2 = \ker d_xf + T_xS$. In the Whitney umbrella a refinement of the stratification can be rather obtained by noticing that the line $\{x_2 = 0\}$ is the locus where the map is not injective.

If $f \in \mathcal{R}$ as in Proposition 8.10, a tentative refinement of the stratification $\{\Sigma^i(f)\}$ would be defined by recurrence as follows: assume that for every multi-index of length k , $I = (i_1, \dots, i_k)$ is defined $\Sigma^I(f) \subset M$, then for every multi-index of length $k+1$, $\tilde{I} = (i_1, \dots, i_k, i_{k+1})$, set $\Sigma^{\tilde{I}}(f) := \Sigma^{i_{k+1}}(f|_{\Sigma^I(f)})$. It is not evident that this eventually produces a nice (sub) stratification. The correct way to do (see [Bo]) is to extend the above stratification \mathcal{S}_Σ of $J^1(M, N)$, to get a nice stratification $\tilde{\mathcal{S}}_\Sigma$ and extend Proposition 8.10.

8.2.4. Multi-transversality. Assume for example that $f : M \rightarrow N$ is an immersion, and for simplicity M is connected. Then the nice stratification of M consists of one stratum $\Sigma^0(f) = M$. This does not give any information about the image of f . Clearly this last might be “non generic”. We say that an immersion f is *in general position* if for every $k \geq 2$, whenever $y = f(x_1) = f(x_2) = \dots = f(x_k)$ and the points x_1, \dots, x_k are distinct, then

$$T_y N = df_{x_k}(T_{x_k} M) + \bigcap_{j=1}^{k-1} df_{x_j}(T_{x_j} M) .$$

For example if $\dim N = 2 \dim M$, then the multiple points y are isolated and are image of exactly two points of M . The following is a basic example of multi-transversality result.

PROPOSITION 8.12. *Let M, N verify the hypotheses of Theorem 8.9. Assume that the open set $Im(M, N)$ of immersions of M in N is non empty. Then the set of immersions in general position is open and dense in $Im(M, N)$.*

The general concept of multi-jet-transversality was introduced in [Ma2]. One considers the products $J^r(M, N)^k$, $k \geq 1$. Then for every $f \in \mathcal{E}(M, N)$ we have the product map $(j^r f)^k : M^k \rightarrow J^r(M, N)^k$. So for every submanifold V of $J^r(M, N)^k$ we can consider f such that $(j^r f)^k \pitchfork V$. The submanifolds V of most interest are as follows:

- Given submanifolds V_i of $J^r(M, N)$, $1 \leq i \leq k$, consider the product $\prod V_i \subset J^r(M, N)^k$;
- There is a natural projection $\tau_k : J^r(M, N)^k \rightarrow N^k$. Then take

$$V = \tau_k^{-1}(\Delta_k N) \cap \prod V_i$$

where $\Delta_k(N) = \{(y, \dots, y)\} \subset N^k$ is the (multi) diagonal of N^k .

Multi-transversality to such a manifold V means that the following conditions are satisfied:

- If $f(x_i) = y$ for every $i = 1, \dots, k$, then f is transverse to V_i at x_i with pre-image say $X_i = f^{-1}(V_i)$;

- The images say B_i of $T_{x_i}X_i$ in T_yN satisfy

$$(\oplus_i B_i) \oplus T_{(y, \dots, y)} \Delta_k(N) = (T_y N)^k .$$

Finally, in the same hypotheses, one gets [**Ma2**] a multi-transverse version of Theorem 8.9.

Morse functions and handle decompositions

Let us call *smooth triad* a triple (M, V_0, V_1) where M is a compact smooth m -manifold with (possibly empty) boundary, V_0 and V_1 are union of connected components of ∂M , so that the boundary is the *disjoint union*

$$\partial M = V_0 \amalg V_1 .$$

A boundaryless M corresponds to the triad $(M, \emptyset, \emptyset)$. We stress that different ordered bipartitions of the components of ∂M give rise to different triads. For example if $\partial M \neq \emptyset$, then $(M, \partial M, \emptyset)$ and $(M, \emptyset, \partial M)$ are different triads. We know from Proposition 5.38 that generic Morse functions form a dense open set in $\mathcal{E}(M, V_0, V_1)$, the space of functions $f : M \rightarrow [0, 1]$ such that $V_j = f^{-1}(j)$, $j = 0, 1$ and without critical points on a neighbourhood of ∂M . Let $f : M \rightarrow [0, 1]$ be such a generic Morse function on the triad (M, V_0, V_1) . We have a finite set of non degenerate critical points p_0, \dots, p_s of indices q_0, \dots, q_s , and critical values $c_r = f(p_r)$, such that $0 < c_r < c_{r+1} < 1$, $r = 0, \dots, s - 1$. For every $X \subset [0, 1]$, denote $V_X := f^{-1}(X)$. For every regular value a of f , V_a is a compact boundaryless submanifold of M of dimension $m - 1$. If $0 \leq a < b \leq 1$ are regular values, then we have the subtriad $(V_{[a,b]}, V_a, V_b)$.

The following lemma ultimately is an instance of a fibration theorem. We give a “non embedded” proof by assuming a few results of analysis about the existence, the uniqueness and the regular dependence on the data for ordinary differential equations.

LEMMA 9.1. (Cylinder Lemma) *Assume that $[a, b] \subset [0, 1]$ does not contain any critical value of f . Then there is a diffeomorphism $\psi : V_a \times [a, b] \rightarrow V_{[a,b]}$ such that $f \circ \psi(y, t) = t$ for every $y \in V_a$.*

Proof : Fix an auxiliary riemannian metric g on M and let $\nabla_g f$ the associated gradient field of f , which is non zero everywhere on $V_{[a,b]}$. We can normalize it by taking for every $p \in V_{[a,b]}$,

$$\nu(p) = \nabla_g f(p) / \|\nabla_g f(p)\|_{g(p)} .$$

Every integral curve α of ν verifies $f(\alpha(s)) = s + c$, c being a constant. Possibly by means of the change of parameter $\beta(t) = \alpha(t - c)$, we can assume that $f(\alpha(t)) = t$. Since $V_{[a,b]}$ is compact every maximal integral curve is defined on the whole $[a, b]$. Then for every $y \in V_a$ there is a unique maximal integral curve of ν

$$\alpha_y : [a, b] \rightarrow V_{[a,b]}$$

such that $\alpha(a) = y$, and $f(\alpha(t)) = t$ for every $t \in [a, b]$. The required diffeomorphism is defined by $\psi(y, t) = \alpha_y(t)$, with inverse $\psi^{-1}(x) = (\alpha_x(a), f(x))$, where α_x is the unique maximal integral curve passing through $x \in V_{[a,b]}$. □

REMARK 9.2. Via the existence of embeddings of compact manifolds in some \mathbb{R}^n , we are currently exploiting the results obtained for compact embedded manifolds. However, in several situations we could provide also an “abstract” treatment. For example, the *existence* of collars of ∂M in M is an immediate consequence of Lemma 9.1, provided that one knows that $\mathcal{E}(M, \partial M, \emptyset)$ is non empty. This last fact

can be obtained as follows: fix a nice atlas of M . Define local functions as follows: if (W, ϕ) is an internal chart, then f_j is the constant function equal to $1/2$. If

$$\phi_j : (W_j, W_j \cap \partial M) \rightarrow (B^m \cap \mathbf{H}^m, B^m \cap \partial \mathbf{H}^m)$$

is a chart at the boundary, then f_j is the restriction of the projection of B^m to the x_m -axis. By using the partition of unity subordinate to the atlas, define

$$f = \sum_j \lambda_j f_j .$$

One can check directly that f has the desired properties.

Strictly speaking in Chapter 5 we have proved the collars *uniqueness up to isotopy* only for the ones realized by means of that (embedded) construction. In fact it holds in full generality (see [Mu]). However we do not really need this fact, so we omit the somewhat technical proof. Also the density of Morse functions can be obtained in an abstract way; the result about the generic linear projections to lines gives us a “local” density for representations in local coordinates, then one uses nice atlas and partitions of unity to get the global result.

9.1. Dissections carried by generic Morse functions

First we fix a nice atlas with collars on the triad (M, V_0, V_1) adapted to the given Morse function $f : M \rightarrow [0, 1]$. This means the following facts:

- The collars are of the form $V_{[0, \epsilon_0]}$, $V_{[1 - \epsilon_0, 1]}$, for some $\epsilon_0 > 0$, $\epsilon_0 < c_0 = f(p_0)$, $c_s = f(p_s) < 1 - \epsilon_0$;
- every critical point p_r of f is contained in a unique internal normal chart (W_r, ϕ_r) , in such a way that $B_r \cap B_{r'} = \emptyset$ if $r \neq r'$ (recall that $B_r = \phi_r^{-1}(B^m(0, 1/3))$);
- Every (W_r, ϕ_r) is such that $(f \circ \psi_r - c_r) : B^m(0, 1/3) \rightarrow \mathbb{R}$ is in normal form according to Morse’s Lemma of Section 5.33 at $0 = \phi_r(p_r)$.

Certainly such an adapted atlas exists. Then we take $\epsilon > 0$ such that

- $\epsilon_0 < c_0 - \epsilon$, $c_0 + \epsilon < c_1 - \epsilon$, \dots , $c_{s-1} + \epsilon < c_s - \epsilon$, $c_s + \epsilon < 1 - \epsilon_0$;
- for every $r = 0, \dots, s$, $V_{c_r - \epsilon} \cap B_r \neq \emptyset$ and $V_{c_r + \epsilon} \cap B_r \neq \emptyset$, so that $V_{[c_r - \epsilon, c_r + \epsilon]}$ is the union of $V_{[c_r - \epsilon, c_r + \epsilon]} \cap B_r$ and its complement.

So we have the *dissection* of the triad (M, V_0, V_1) associated to the Morse function f :

$$V_{[0, c_0 - \epsilon]} \cup V_{[c_0 - \epsilon, c_0 + \epsilon]} \cup V_{[c_0 + \epsilon, c_1 - \epsilon]} \cup V_{[c_1 - \epsilon, c_1 + \epsilon]} \cup \dots \cup V_{[c_s - \epsilon, c_s + \epsilon]} \cup V_{[c_s + \epsilon, 1]} .$$

By applying the cylinder and Thom’s lemmas, we have that

- $V_{[0, c_0 - \epsilon]} \sim V_0 \times [0, c_0 - \epsilon]$, $V_{[c_s + \epsilon, 1]} \sim [c_s + \epsilon, 1] \times V_1$;
- for every $r = 0, \dots, s - 1$, $V_{[c_r + \epsilon, c_{r+1} - \epsilon]} \sim V_{c_r + \epsilon} \times [c_r + \epsilon, c_{r+1} - \epsilon]$;
- $V_{[0, c_r + \epsilon]} \sim V_{[0, c_{r+1} - \epsilon]}$.

For every $r = 0, \dots, s - 1$, $(V_{[c_r - \epsilon, c_r + \epsilon]}, V_{c_r - \epsilon}, V_{c_r + \epsilon})$ is an *elementary triad* in the sense that it carries a Morse function (the restriction of f) with *only one* critical point (p_r of a given index q_r).

Adapted gradient fields. By using the above adapted nice atlas of (M, V_0, V_1) with respect to f , we can construct an adapted riemannian metric g on M , so that for every $r = 0, \dots, s$, the gradient field $\nabla f := \nabla_g f$ has the normalized expression in the local coordinates over B_r :

$$2(-x_1, -x_2, \dots, -x_{q_r}, x_{q_r+1}, \dots, x_m)$$

while the collars of V_0 and V_1 are obtained by integrating such a (normalized) field as in the proof of Lemma 9.1.

So the key point will be to understand what happens up to diffeomorphism by passing from $V_{[0,c_r-\epsilon]}$ to $V_{[0,c_r+\epsilon]}$ (equivalently to $V_{[0,c_{r+1}-\epsilon]}$) through such an elementary triad. It is evident that the choice of the parameters ϵ_0 and ϵ is immaterial. An answer is given by the following Proposition. We refer to notions introduced in Chapter 7. The proof is extracted from [Pa].

PROPOSITION 9.3. *Let $f : M \rightarrow [0, 1]$ be a generic Morse function on the triad (M, V_0, V_1) and consider an associated dissection. Let p be a critical point of f of index q , and c' be the next critical value of f after $c = f(p)$. Then*

- (1) $V_{[0,c+\epsilon]}$ is diffeomorphic to $V_{[0,c'-\epsilon]}$.
- (2) Up to diffeomorphism, $V_{[0,c+\epsilon]}$ is obtained by attaching a q -handle (of dimension m) to $V_{[0,c-\epsilon]}$ along $V_{c-\epsilon}$.

Proof : As already remarked, (1) follows from the Cylinder and Thom's lemmas.

As for (2), take a nice atlas associated to the given Morse dissection of (M, V_0, V_1) . Take the Morse chart $(\psi(B), \phi)$ at p , so that in that local coordinates, $\phi(p) = 0$, and

$$\hat{f} = f \circ \psi : B \rightarrow \mathbb{R}$$

has the normal form

$$\hat{f}(x_1, \dots, x_m) = -(x_1^2 + \dots + x_q^2) + (x_{q+1}^2 + \dots + x_m^2) + c.$$

According to our usual conventions, B should be $B^m(0, 1/3)$, but up to reparametrization we can normalize the picture as follows. First we simplify the notations by setting

$$(x_1, \dots, x_q, x_{q+1}, \dots, x_m) = (X, Y) \in \mathbb{R}^q \times \mathbb{R}^{m-q}.$$

Then we can assume that:

- $f : M \rightarrow [a_0, a_1]$ for suitable $a_0 < -1$, $1 < a_1$;
- $B = B^m(0, 2)$, $\hat{f}(0) = c = 0$, $\epsilon = 1$;
- $B \cap \phi(W \cap V_{[a_0, -1]}) = \{(X, Y) \in B; -\|X^2\| + \|Y\|^2 \leq -1\}$;
- $B \cap \phi(W \cap V_{[a_0, 1]}) = \{(X, Y) \in B; -\|X^2\| + \|Y\|^2 \leq 1\}$.

The standard handle $H^q = D^q \times D^{m-q}$ is contained into

$$B \cap \phi(W \cap V_{[-1, 1]}) = \{(X, Y) \in B; -1 \leq -\|X^2\| + \|Y\|^2 \leq 1\}$$

and H^q intersects $\{-\|X^2\| + \|Y\|^2 = \pm 1\}$ along the union of its a and b -spheres. Moreover, if $H' = (\mathbb{R}^q \times D^{m-q}) \cap \{-1 \leq -\|X^2\| + \|Y\|^2 \leq 1\}$, then $V_{[a_0, -1]} \cup \psi(H')$ is a submanifold with corners of $V_{[a_0, 1]}$ obtained by attaching the q -handle to $V_{[0, -1]}$ along V_{-1} . The idea is to modify the inclusion of H' to an embedding j of H^q (actually an embedded corner smoothing) in such a way that:

- (1) $\mathcal{H} := j(H^q) \subset \{(X, Y) \in B; -1 \leq -\|X^2\| + \|Y\|^2 < 1\}$.
- (2) $\mathcal{H} \cap \{-\|X^2\| + \|Y\|^2 = -1\} = j(\mathcal{T}_a)$, the image of the a -tube.
- (3) The embedding j is still equal to the identity at the core of the handle.
- (4) $\tilde{M} := V_{[a_0, -1]} \cup \psi(\mathcal{H})$ is a smooth submanifold of $V_{[a_0, 1]}$ obtained by attaching the q -handle to $V_{[0, -1]}$ along V_{-1} , having the restriction of j to \mathcal{T}_a as attaching map.
- (5) $V_{[a_0, 1]} \setminus \tilde{M}$ is a collar of V_1 in $V_{[a_0, 1]}$.

Take the 1-dimensional bump function $\gamma = \gamma_{1/2, 1}$; then define

$$\hat{g} : B \rightarrow \mathbb{R}; \hat{g}(X, Y) = -\|X\|^2 + \|Y\|^2 - \frac{3}{2}\gamma(\|Y\|^2).$$

Clearly

$$\{\hat{g} \leq -1\} = \{\hat{f} \leq -1\} \cup (\{\hat{f} \geq -1\} \cap \{\hat{g} \leq -1\}) := \{\hat{f} \leq -1\} \cup \mathcal{H}$$

and \mathcal{H} intersects $\{\hat{f} \leq -1\}$ at $\{\hat{f} = -1\}$; $\{\hat{g} \leq -1\}$ is contained in the interior of $\{\hat{f} \leq 1\}$, and $\{\hat{f} \leq 1\} = \{\hat{g} \leq 1\}$.

Claim: \mathcal{H} is q -handle attached to $\{\hat{f} \leq -1\}$ along $\{\hat{f} = -1\}$, via a characteristic map $H : D^q \times D^{m-q} \rightarrow \mathcal{H}$ which is the identity on the core $D^q \times \{0\}$.

We are going to write down the explicit formulas establishing the claim. Several verifications are understood; for all details (in a more general setting) we refer to [Pa]. The smooth function $\sigma : [0, 1] \rightarrow \mathbb{R}$ is uniquely defined by the equation

$$\frac{\gamma(\sigma(s))}{1 + \sigma(s)} = \frac{2}{3}(1 - s).$$

The function σ is strictly increasing, $\sigma(0) = \frac{1}{2}$, $\sigma(1) = 1$ and moreover we have that for every $(X, Y) \in \mathcal{H}$,

$$\|Y\|^2 < \sigma\left(\frac{\|X\|^2}{1 + \|Y\|^2}\right).$$

By using σ and its properties, we can give the explicit characteristic map

$$H : D^q \times D^{m-q} \rightarrow \mathcal{H}$$

$$H(X, Y) = (\sqrt{\sigma(\|X\|^2)\|Y\|^2 + 1} X, \sqrt{\sigma(\|X\|^2)} Y)$$

which restricts to the attaching map

$$h : S^{q-1} \times D^{m-q} \rightarrow \partial\mathcal{H} \subset \{\hat{f} = -1\}$$

$$h(X, Y) = (\sqrt{\|Y\|^2 + 1} X, Y).$$

Let us consider now

$$M' := [\{f \geq -1\} \cap (M \setminus \psi(B))] \cup \psi(\{(X, Y) \in B; \hat{g} \geq -1\}).$$

By construction, the functions f and $\hat{g} \circ \phi$ match on M' , giving us a global function $g : M' \rightarrow \mathbb{R}$, such that

$$\{f \leq 1\} = \{f \leq -1\} \cup \psi(\mathcal{H}) \cup \{p \in M'; -1 \leq g \leq 1\}.$$

The final remark is that $[-1, 1]$ does not contain critical values of g . It is enough to verify it for \hat{g} on B . In fact

$$\nabla \hat{g}(X, Y) = 2(-X, Y) - 2(0, \gamma'(\|Y\|^2)Y)$$

which vanishes only at 0 because $\gamma' \leq 0$ on $(0, +\infty)$. Summarizing, as

$$\{f \leq -1\} \cup \psi(\mathcal{H})$$

is obtained by attaching a q -handle to $\{f \leq -1\}$ along $\{f = -1\}$, by applying the Cylinder Lemma to g over $[-1, 1]$ we conclude that also $\{f \leq 1\}$ is obtained by attaching a q -handle to $\{f \leq -1\}$ along $\{f = -1\}$. Ultimately, by restoring the usual notations, $V_{[0, c+\epsilon]}$ is obtained by attaching a q -handle to $V_{[0, c-\epsilon]}$ along $V_{c-\epsilon}$. \square

REMARK 9.4. With the notations of (the proof of) Proposition 9.3, we realize that the core $D^q \times \{0\}$ of the q -handle \mathcal{H} is formed by the integral lines of the adapted gradient field ∇f which start at a point of $V_{c-\epsilon}$ and end in the critical point p . If $c - \epsilon > \delta > 0$ is any value such that $[\delta, c - \epsilon]$ does not contain any critical value of f , then again by the Cylinder Lemma, $V_{[0, c+\epsilon]}$ is also obtained by attaching a q -handle say \mathcal{H}' to $V_{[0, \delta]}$ along V_δ . As well as the core of \mathcal{H} and the relative attaching map h look “simple and local”, the core and the relative attaching map h' of \mathcal{H}' can be “far from $V_{c-\epsilon}$ and complicated”. In fact h' is obtained by composing h with the diffeomorphism between $V_{c-\epsilon}$ and V_δ provided by the Cylinder Lemma; again the core of \mathcal{H}' is formed by the integral lines of the adapted gradient ∇f (used in the Cylinder Lemma) which start at a point of V_δ and end in p .

9.2. Handle decompositions

Let (M, V_0, V_1) be a triad as before. By definition, a *handle decomposition* of the triad is a sequence of nested triads of the form

$$(M_0, V_0, V_{1,0}) \subset (M_1, V_0, V_{1,1}) \subset (M_2, V_0, V_{1,2}) \subset \cdots \subset (M_k, V_0, V_{1,k})$$

such that

- $V_{1,k} = V_1$, and (M_k, V_0, V_1) is diffeomorphic to (M, V_0, V_1) via a diffeomorphism which is the identity in a neighbourhood of $V_0 \amalg V_1$;
- For every $r = 0, \dots, k - 1$, $(M_{r+1}, V_0, V_{1,r+1})$ is obtained by attaching a q -handle (of dimension m) to $(M_r, V_0, V_{1,r})$ along $V_{1,r}$ (for some q).

Two handle decompositions are diffeomorphic if they are related by a diffeomorphism which is the identity near the boundary and respects the sequences of nested triads. We can also *normalize* the form of a given handle decomposition by stipulating that it starts with a “right” collar C_0 of V_0 and ends with a “left” collar C_1 of V_1 .

As an immediate Corollary of Proposition 9.3 we have the *existence* of handle decompositions for every triad.

COROLLARY 9.5. *Every triad (M, V_0, V_1) admits handle decompositions.*

Proof : Take a dissection carried by any generic Morse function on the triad. The sequence of nested submanifolds

$$V_{[0, c_0 - \epsilon]} \subset V_{[0, c_1 - \epsilon]} \subset V_{[0, c_2 - \epsilon]} \subset \cdots \subset V_{[0, 1]}$$

leads to a desired handle decomposition. □

Sometimes a handle decomposition of (M, V_0, V_1) (in normalized form) is formally indicated as

$$C_0 \cup H_1^{q_1} \cup H_2^{q_2} \cup \cdots \cup H_k^{q_k} \cup C_1$$

where C_0 and C_1 are the respective collars of V_0 and V_1 , and for $r = 0, \dots, k - 1$, $M_r = C_0 \cup H_1^{q_1} \cup H_2^{q_2} \cup \cdots \cup H_r^{q_r}$, M_{r+1} is obtained by attaching the q_{r+1} -handle $H_{r+1}^{q_{r+1}}$ to M_r , along $V_{1,r}$. Sometimes we will omit to indicate the index q_r .

The dual decompositions. Given a triad (M, V_0, V_1) , the *dual triad* is by definition (M, V_1, V_2) . Given a decomposition \mathcal{H} of the triad (M, V_0, V_1) formally indicated as

$$C_0 \cup H_1^{q_1} \cup H_2^{q_2} \cup \cdots \cup H_k^{q_k} \cup C_1$$

we can consider the dual decomposition \mathcal{H}^* of (M, V_1, V_0) obtained by going from C_1 to C_0 in the opposite direction. Every q -handle H^q of \mathcal{H} is converted into a “dual” $(m - q)$ -handle $(H^*)^{m - q}$ of \mathcal{H}^* where the core and the cocore exchange their roles. If \mathcal{H} is associated to a Morse function f , then \mathcal{H}^* is associated to the function $f^* = 1 - f$.

Once we have obtained the existence of handle decompositions, we will develop our discussion in terms of these last, somehow forgetting the Morse functions. To this respect Morse functions have been rather a tool in order to produce handle decompositions. On another hand, one can prove that

For every handle decomposition of a triad, there is a Morse function that recovers it, so that every q -handle corresponds to a critical point of index q .

So handle decompositions and Morse functions (with the associated dissections) *basically are equivalent stuff*. This means that any manipulation in terms of handle decompositions should have a counterpart in the realm of Morse functions. One can find such a purely Morse function approach in [M3]. However, dealing directly

with handle decompositions is often easier and topologically transparent with respect to its Morse function counterpart which can be demanding. Moreover, handle technology works as well even for other categories of manifolds (like the *piecewise-linear* (PL) one, see [RS]) where there is *not* a Morse function counterpart. For these reasons we will not pursue the equivalence between Morse function and handle approaches, preferring the latter.

9.3. Moves on handle decompositions

There are two basic ways to modify a given handle decomposition of a triad (M, V_0, V_1) (up to diffeomorphism equal to the identity on a neighbourhood of $V_0 \amalg V_1$).

Handle sliding. This is a synonymous of modifying the attaching map of a handle, say H_r , in the decomposition staying in the same isotopy class. We have already noticed in Chapter 7 that up to diffeomorphism this does not modify M_r , then we can continue the decomposition by composing the subsequent attaching maps with such a diffeomorphism, finally obtaining a decomposition diffeomorphic to the given one (possibly by attaching a final collar of V_1 in order to normalize the form).

Before stating the other modification, let us give a definition.

DEFINITION 9.6. Let

$$\dots \cup H_r^{q_r} \cup H_{r+1}^{q_{r+1}} \cup \dots$$

be a fragment of a handle decomposition of a triad (M, V_0, V_1) . Assume that $q_r = q$, $q_{r+1} = q + 1$. Both the embedded b -sphere S_b of H_r^q (which is diffeomorphic to S^{m-q-1}) and the embedded a -sphere S_a of H_{r+1}^{q+1} (which is diffeomorphic to S^q) are submanifolds of the $(m-1)$ -manifold $V_{1,r}$, and $\dim S_b + \dim S_a = m-1$. Then the adjacent handles $H_r \cup H_{r+1}$ form a *pair of complementary handles* provided that S_b and S_a intersect transversely in $V_{1,r}$ at *exactly one point*. Note that under the above dimensional assumptions, by transversality and up to handle sliding we can assume anyway that S_b and S_a intersect transversely at a finite number of points.

Cancelling/inserting pairs of complementary handles. We can state the basic handle cancellation result.

PROPOSITION 9.7. *If*

$$\dots \cup H_r^q \cup H_{r+1}^{q+1} \cup \dots$$

is a pair of complementary handles in a handle decomposition of (M, V_0, V_1) , then $(M_{r-1}, V_0, V_{1,r-1})$ is diffeomorphic to $(M_{r+1}, V_0, V_{1,r+1})$. Hence we can cancel the pair and get a handle decomposition of the form

$$C_0 \cup H_1^{q_1} \cup \dots \cup H_{r-1}^{q_{r-1}} \cup H_{r+2}^{q_{r+2}} \dots \cup H_k^{q_k} \cup C_1 .$$

Reciprocally, we can freely insert a pair of complementary handles between any two adjacent handles into a given decomposition.

We postpone the proof below.

A key problem is to study the handle decompositions of a given triad up to the *move-equivalence* relation generated by such basic moves. In fact by using Cerf's theory [Ce2] (see [Kirby]), one can prove the following fact.

THEOREM 9.8. *Any two handle decompositions of a triads (M, V_0, V_1) are move-equivalent to each other.*

We will not prove nor use such a rather demanding result. We limit to some remarks and simple applications.

- For every handle decomposition \mathcal{H} of (M, V_0, V_1) set

$$\chi(\mathcal{H}) = \sum_q (-1)^q |\mathcal{H}_q|$$

where $|\mathcal{H}^q|$ denotes the number of q -handle of \mathcal{H} . Obviously this *characteristic* of \mathcal{H} is move-equivalence *invariant*. We will see later that $\chi(\mathcal{H})$ has in fact an intrinsic topological meaning (see Remark 14.2).

- The following is a first important application of sliding handle in order to specialize the handle decompositions. Let us give first a definition

DEFINITION 9.9. A handle decomposition of (M, V_0, V_1) is said *ordered* if

- For every $q = 0, \dots, m - 1$, the $q + 1$ handles are attached after the q -handles;
- For every $q = 0, \dots, m$, the q -handles are attached simultaneously. Precisely, if \mathcal{H}^q denotes the pattern of q -handle, $M_{q-1} = C_0 \cup \mathcal{H}_0 \cup \dots \cup \mathcal{H}_{q-1}$ then the attaching maps of the handles in \mathcal{H}_q have disjoint images in $V_{1,q-1}$.

PROPOSITION 9.10. (Reordering) *By handle sliding, every handle decomposition of (M, V_0, V_1) can be transformed into an ordered decomposition.*

Proof : Let

$$\dots \cup H_r^{q_r} \cup H_{r+1}^{q_{r+1}} \cup \dots$$

be a fragment of a given handle decomposition \mathcal{H} . Set $q_r = p$, $q_{r+1} = q$, and assume that $p \geq q$. Then the embedded b -sphere S_b of H_r^p is diffeomorphic to S^{m-p-1} while the embedded a -sphere S_a of H_{r+1}^q is diffeomorphic to S^{q-1} . Then $\dim S_b + \dim S_a \leq m - 2 < m - 1$. Up to handle sliding, we can assume that S_b and S_a are transverse submanifolds of the $(m - 1)$ -manifold $V_{1,r}$, so that $S_b \cap S_a = \emptyset$. There is a tubular neighbourhood U of S_b contained in the b -tube T_b around S_b , such that $S_a \cap U = \emptyset$; T_b itself is a tubular neighbourhood of S_b . Hence by the uniqueness of the tubular neighbourhood up to isotopy and the extension of isotopy to diffeotopy, there is a diffeotopy of $V_{1,r}$ which keeps S_b fixed and pushes the complement of U in T_b (hence S_a) outside T_b . It follows that up to handle sliding the two handles have now disjoint attaching tubes so that we can attach them in the inverse order or even simultaneously. The proposition follows by several applications of this argument. \square

REMARK 9.11. In terms of Morse functions, the last proposition corresponds to the existence of Morse functions such that critical points of the same index share the same critical value, and the critical values strictly increase together with the corresponding indices.

Proof of Proposition 9.7. Let us consider first the simplest case $q = 0$. Attaching a 0-handle means “create” a new disjoint m -ball component

$$H_r^0 = D^m = \{0\} \times D^m .$$

The whole boundary S^{m-1} forms the b -sphere. If the 1-handle H_{r+1}^1 is complementary to H_r^0 , then its attaching map embeds one component of

$$\partial D^1 \times D^{m-1} = \{-1, 1\} \times D^{m-1}$$

into S^{m-1} , while the other component is embedded into $V_{1,r-1} = V_{1,r} \setminus S^{m-1}$. The partial attachment of $D^1 \times D^{m-1}$ to D^m is a shelling (refer to Section 7.5) of D^m producing another diffeomorphic copy of D^m . Then the remaining component of

the attaching map finally produces a shelling of M_{r-1} hence a diffeomorphic copy of it. The same facts hold in the general case by a more elaborate argument. Assume first that the complementary handles have normalized attaching maps as follows. Let us decompose the b -sphere S_b of H_r^q as $S_b = D_b^+ \cup D_b^-$, where both D_b^\pm are diffeomorphic to D^{m-q-1} and intersect along an equatorial $(m-q-2)$ -sphere. Then the b -tube around S_b is given as $T_b = D^q \times (D_b^+ \cup D_b^-)$. Similarly for the a -sphere and the a -tube of H_{r+1}^{q+1} , let $S_a = D_a^+ \cup D_a^-$, $D_a^\pm \sim D^q$, $D_a^+ \cup D_a^- \sim S^{q-1}$, $T_a = (D_a^+ \cup D_a^-) \times D^{m-q-1}$. Assume that the intersection, say A , between the image of the attaching map of H_{r+1}^{q+1} and T_b is equal to $D^q \times D_b^+$, and that the inverse image of A , say \hat{A} , is equal to $D_a^+ \times D^{m-q-1}$, so that $\hat{A} \sim A$ and $\hat{A} \cap S_a = D_a^+$ is mapped onto $D^q \times \{x_0\}$, x_0 being the ‘centre’ of D_b^+ . In such a normalized situation, we can factorize the attachment of the pattern made by the two complementary handles as follows:

- (1) First glue H_{r+1}^{q+1} to H_r^q by using as attaching map the restriction of the whole attaching map to \hat{A} . This is a shelling of a disk, so it results a smooth m -disk with a residual attaching zone contained in the boundary and diffeomorphic to a $(m-1)$ -disk.
- (2) Perform the residual attachment; actually this is a further shelling over M_{r-1} .

This achieves the result in the normalized situation. In our hypothesis, a priori we have such a normalized situation provided we replace the whole b -tube T_b with a smaller tubular neighbourhood U of S_b contained in T_b . Now, similarly to the proof of Proposition 9.10, by the uniqueness of the tubular neighbourhood up to isotopy and the extension of isotopy to diffeotopy, there is a diffeotopy which keeps S_b fixed and transforms $U \cup H_{r+1}^{q+1}$ to a pair of complementary handles in normal situation. This completes the proof. \square

- A measure of the complication of a given handle decomposition is the *total number of handles*. For example if it is equal to 0, then (M, V_0, V_1) is diffeomorphic to the *product triad* $(V_0 \times [0, 1], V_0, V_0)$, in particular V_0 and V_1 are diffeomorphic; if a boundaryless M has a decomposition with only one 0-handle and one m -handle, then M is a twisted sphere. A natural task is to try to reduce such a complication by applying to a given decomposition some instances of the basic moves. The following is a first simple but useful step in this direction.

PROPOSITION 9.12. (Cancellation of 0- and m -handles) *Assume that M is connected. Then:*

- (1) *For every triad of the form $(M, \emptyset, \emptyset)$ (i.e. M is boundaryless), every handle decomposition \mathcal{H} is move-equivalent to an ordered decomposition \mathcal{H}' with only one 0-handle and only one m -handle.*
- (2) *For every triad of the form $(M, \emptyset, \partial M)$, $\partial M \neq \emptyset$, every handle decomposition \mathcal{H} is move-equivalent to an ordered decomposition \mathcal{H}' with only one 0-handle and without m -handles.*
- (3) *For every triad of the form $(M, \partial M, \emptyset)$, $\partial M \neq \emptyset$, every handle decomposition \mathcal{H} is move-equivalent to an ordered decomposition \mathcal{H}' with only one m -handle and without 0-handles.*
- (4) *For every triad of the form (M, V_0, V_1) , both V_0 and V_1 being non empty, every handle decomposition \mathcal{H} is move-equivalent to an ordered decomposition \mathcal{H}' without both 0- and m -handles.*

Proof : Let us prove (1) and (2) simultaneously. By handle sliding we can assume that the decomposition is ordered. Assume that we have attached a certain number of 0-handles, that is we have created a set of disjoint components diffeomorphic to D^m . The only way to restore the fact that M is connected is by means of

the 1-handles. By successive application of elimination of complementary $H^0 \cup H^1$ or reordering we eventually reach two possible situations: either we remain with only one 0-handle and this happens when $V_0 = \emptyset$ (if there are no longer complementary $H^0 \cup H^1$ to eliminate then M would be not connected), or we remain with no 0-handles and this happens when $V_0 \neq \emptyset$ and the 1-handles connect to each other all the components of C_0 . To deal with the m -handles is enough to apply the same argument to the dual decomposition. □

REMARK 9.13. In terms of Morse functions, for example the first case of the above proposition corresponds to the existence of functions with only one minimum and one maximum. Similarly for the other cases.

9.3.1. The CW complex associated to an ordered decomposition. Let M be boundaryless. Let

$$H^0 \cup \{H^1\} \cup \{H^2\} \cdots \cup \{H^{m-1}\} \cup H^m$$

be an ordered handle decomposition of the triad $(M, \emptyset, \emptyset)$ with one 0-handle and one m -handle; $\{H^j\}$ means a (possibly empty) pattern of i_j j -handles attached simultaneously. Every handle H has a natural retraction

$$r : H \rightarrow \text{core}(H) \cup a\text{-tube}(H)$$

which realizes a homotopy equivalence. By using the notations fixed above, we are going to construct inductively homotopy equivalence

$$l_j : W_j \rightarrow K_j$$

where K_0 consists of one point and K_j will be obtained by attaching i_j j -cells to K_{j-1} ; we eventually get a homotopy equivalence

$$l : M \rightarrow K, \quad K = K^m$$

where (by the very definition of this term) K is a *finite CW-complex of dimension m* . So, let K_0 be the core of H^0 ; then $l_0 : M_0 \rightarrow K_0$ is an instance of retraction r as above. Assume we have defined $l_{j-1} : M_{j-1} \rightarrow K_{j-1}$. Then

$$M_j = M_{j-1} \cup_{\{h_j\}} \{H^j\}$$

is homotopy equivalent (via the retraction $l_j := l_{j-1} \circ \{r_j\}$) to

$$K_j = K_{j-1} \cup_{\{g_j\}} \{D^j\}$$

where $\{g_j\}$ is the restriction of $l_{j-1} \circ \{h_j\}$.

Assume now that ∂M is not empty and consider the triad $(M, \partial M, \emptyset)$. In such a case the ordered handle decomposition has no m -handles, hence there is an homotopy equivalence $l : M \rightarrow K$ where K is a *finite CW-complex of dimension $d \leq m - 1$* .

9.4. Compact 1-manifolds

We use the handle technology developed so far in order to classify compact 1-manifolds up to diffeomorphism. This is simple and intuitive; nevertheless it is a fundamental result with many applications (see Chapter 11). It is not restrictive to assume that these manifolds are connected.

PROPOSITION 9.14. (1) *A compact connected boundaryless 1-manifold is diffeomorphic to S^1 .*

(2) *A compact connected 1-manifold with non empty boundary is diffeomorphic to the interval D^1 .*

Proof : In both cases apply Proposition 9.12. In the second case there is a handle decomposition of $(M, \emptyset, \partial M)$ formed by one 0-handle (of dimension 1). Hence $(M, \emptyset, \partial M)$ is diffeomorphic to $(D^1, \emptyset, \{\pm 1\})$. In the second case there is a handle decomposition of $(M, \emptyset, \emptyset)$ formed by one 0-handle and one 1-handle (of dimension 1). Hence M is a twisted 1-sphere and we know from Chapter 7 that it is diffeomorphic to S^1 . □

Bordism

For every $m \geq 0$, denote by \mathcal{S}_m the class of smooth compact (not necessarily connected) boundaryless m -manifolds. A natural question would be to classify the elements of \mathcal{S}_m up to *diffeomorphism*. We can also specialize the question to the class \mathcal{O}_m of oriented manifolds up to oriented diffeomorphism. Sometimes we will use \mathcal{M}_m to indicate indifferently either \mathcal{S}_m or \mathcal{O}_m . It turns out that beyond $m \leq 2$ these are very demanding, even hopeless questions. Then it is natural to relax the diffeomorphism to a suitable equivalence up to (possibly oriented) *bordism*.

On another hand, homotopy groups $\pi_m(X, x_0)$ of any pointed topological space (X, x_0) provide the basic examples of topological/algebraic functors and are constructed by implementing the following idea: to get information about a complicated “unknow” space X , continuously map into it “tame” spaces (the m -sphere) and study the behaviour of these *singular tame* objects in X up to homotopy which is a sort of basic prototype of bordism between maps. Note that the singular “tame” objects are in general not so simple in spite of the tame source spaces because the maps and their images in X can be complicated. The same idea can be implemented by considering singular smooth m -manifolds in X , that is continuous maps $f : M \rightarrow X$ where $M \in \mathcal{M}_m$, up to suitable *bordism of maps* (naturally extending the bordism of manifolds mentioned above). This leads in a simple way to further topological/algebraic functors; once also the relative theory for topological pairs (X, A) has been developed, then one easily checks that these functors verify the so called *Eilenberg-Steenrod axioms* which characterize *generalized homology theories*. Of course all this specializes to the case when X itself belongs to \mathcal{M}_k , for some k . We will develop this topological/differential specialization mainly in Chapter 11.

10.1. The bordism modules of a topological space

Let X be a topological space. For every $m \geq 0$ a *singular smooth m -manifold* in X is a continuous map $f : M \rightarrow X$ where $M \in \mathcal{S}_m$. Denote by

$$\mathcal{S}_m(X)$$

the set of such singular manifolds to which *we formally add the empty set*.

DEFINITION 10.1. $(M, f) \in \mathcal{S}_m(X)$ is a *singular boundary* if there are a compact smooth $(m+1)$ -manifold with boundary $(W, \partial W)$, a diffeomorphism $\rho : M \rightarrow \partial W$, a continuous map $F : W \rightarrow X$ such that $F \circ \rho = f$.

Let us put on $\mathcal{S}_m(X)$ the following relation:

We say that (M_0, f_0) is *bordant with* (M_1, f_1) and we write $(M_0, f_0) \sim_b (M_1, f_1)$ if the disjoint union $(M_0, f_0) \amalg (M_1, f_1)$ is a singular boundary. It is consistent to state that $(M, f) \sim_b \emptyset$ if and only if (M, f) is a singular boundary.

We claim that this is an *equivalence relation*:

- The cylinder $(M \times [0, 1], F)$, $F(x, t) = f(x)$ for every $t \in [0, 1]$, establishes that $(M, f) \sim_b (M, f)$, $\rho : M \amalg M \rightarrow (M \times \{0\}) \amalg (M \times \{1\})$ being the natural inclusion.

- As the disjoint union is symmetric, then also \sim_b is obviously symmetric.

• *Transitivity follows by gluing smooth manifolds along boundary components.* Precisely, assume that (W_0, F_0) , $\rho_0 : M_0 \amalg M_1 \rightarrow \partial W_0$ realize $(M_0, f_0) \sim_b (M_1, f_1)$, while (W_1, F_1) , $\rho_1 : M_1 \amalg M_2 \rightarrow \partial W_1$ realize $(M_1, f_1) \sim_b (M_2, f_2)$. Then F_0 and F_1 match to define a smooth map F_2 on $W_2 := W_0 \amalg_\psi W_1$, where ψ is the composition of the restriction of ρ_0^{-1} to $\rho_0(M_1)$ with the restriction of ρ_1 to M_1 . Finally (W_2, F_2) together with the disjoint union of ρ_0 restricted to M_0 and ρ_1 restricted to M_2 realize $(M_0, f_0) \sim_b (M_2, f_2)$.

We denote by $\eta_m(X)$ the quotient set $\mathcal{S}_m(X)/\sim_b$, by $[M, f]$ the equivalence class of (M, f) .

The disjoint union is an operation on $\mathcal{S}_m(X)$. It is immediate that it descends to the quotient, that is $[M, f] + [N, g] := [M \amalg N, f \amalg g]$ is a well defined operation on $\eta_m(X)$. We have

PROPOSITION 10.2. $(\eta_m(X), +)$ is an abelian group.

Proof : The operation $+$ is associative and commutative because the disjoint union is associative and commutative. $[\emptyset]$ that is the class of the singular boundaries, is the zero element. For every $\alpha = [M, f]$, $-\alpha = \alpha$, in fact by using the cylinder as above we see that $[M, f] + [M, f] = 0$. \square

Since for every α , $\alpha = -\alpha$, then $(\eta_m(X), +)$ can be enhanced to be a $\mathbb{Z}/2\mathbb{Z}$ -module, that is a $\mathbb{Z}/2\mathbb{Z}$ -vector space $(\eta_m(X), +, \cdot)$; we call it the *unoriented m -bordism space* of X .

10.1.1. The oriented bordism \mathbb{Z} -modules. We follow the same scheme by using oriented manifolds.

We denote by $\mathcal{O}_m(X)$ the set of *oriented* singular m -manifolds $f : M \rightarrow X$, that is $M \in \mathcal{O}_m$.

(M, f) is a *singular oriented boundary* if (W, F) , $\rho : M \rightarrow \partial W$ are as above and we require furthermore that $(W, \partial W)$ is oriented and ρ preserves the orientation.

The relation $(M_0, f_0) \sim_{ob} (M_1, f_1)$ on $\mathcal{O}_m(X)$ is defined by requiring that $(M_1, f_1) \amalg (-M_2, f_2)$ is a singular oriented boundary. The verification that it is an equivalence relation is similar:

- the cylinder can be naturally oriented in such a way that its oriented boundary is $M \amalg -M$.

- To get the symmetry it is enough to replace W with $-W$.

- As for the transitivity, we glue again W_0 and W_1 by taking into account that the gluing diffeomorphism ψ reverses necessarily the orientation: in ∂W_0 there is a copy of $-M_1$ while in ∂W_1 there is a copy of M_1 . Hence the gluing can be performed in the oriented category.

We denote by $\Omega_m(X)$ the quotient set. Again the operation $+$ on $\Omega_m(X)$ is induced by the disjoint union on $\mathcal{O}_m(X)$. It results a commutative group (i.e. a \mathbb{Z} -module) $(\Omega_m(X), +)$. Again $0 = [\emptyset]$, that is the class of the singular oriented boundaries. By means of the oriented cylinder we see that $-[M, f] = [-M, f]$. This is the *m -oriented bordism module* of the topological space X .

There is a natural group homomorphism

$$\sigma_m : \Omega_m(X) \rightarrow \eta_m(X)$$

which maps the class of (M, f) in $\Omega_m(X)$ to its class in $\eta_m(X)$, just by “forgetting the orientation”.

As many considerations run formally in the same way for both bordism versions, sometimes we will indifferently indicate by $\mathcal{M}_m(X)$ either $\mathcal{S}_m(X)$ or $\mathcal{O}_m(X)$, and by $\mathcal{B}_m(X) = \mathcal{B}_m(X; R)$ either the quotient R -module $\eta_m(X)$ or $\Omega_m(X)$, $R = \mathbb{Z}/2\mathbb{Z}, \mathbb{Z}$.

LEMMA 10.3. *Let $\phi : N \rightarrow M$ be a diffeomorphism (preserving the orientation in the oriented setting); $f : M \rightarrow X$, $m = \dim M$. Then $[M, f] = [N, f \circ \phi] \in \mathcal{B}_m(X)$*

Proof: The cylinder $(M \times [0, 1], f \circ \pi)$ ($\pi : M \times [0, 1] \rightarrow M$ being the projection), and $\rho : M \amalg N \rightarrow (M \times \{0\}) \amalg (M \times \{1\})$, $\rho = \text{id}_M \amalg \phi$, realize $(M, f) \sim_{\mathcal{B}} (N, f \circ \phi)$. \square

REMARK 10.4. Let (M, f) be a singular boundary in X . Let $((W, \partial W), F)$ and $\rho : M \rightarrow \partial W$ realize $(M, f) \sim_{\mathcal{B}} \emptyset$. By applying Lemma 10.3 we have

$$(M, f) \sim_{\mathcal{B}} (\partial W, \partial F)$$

and this is realized by a cylinder; obviously $((W, \partial W), F)$ and $\text{id}_{\partial W}$ realize

$$(\partial W, \partial F) \sim_{\mathcal{B}} \emptyset .$$

By applying to this situation the gluing argument employed to show the transitivity, we can conclude that it is not restrictive to require that $M = \partial W$ and $\rho = \text{id}_M$

An important special case. When $X = \{x_0\}$ consists of one point, then the maps are immaterial and, by definition, $\mathcal{B}_m := \mathcal{B}_m(\{x_0\})$ is the quotient of \mathcal{M}_m up to *bordism of manifolds*. It follows from Lemma 10.3 that the bordism extends the diffeomorphism equivalence in the category.

10.2. Bordism covariant functors

We have the following Proposition. All verifications are straightforward consequence of the very definitions.

PROPOSITION 10.5. *For every $m \geq 0$,*

$$X \Rightarrow \mathcal{B}_m(X)$$

$$g : X \rightarrow Y \Rightarrow g_* : \mathcal{B}_m(X) \rightarrow \mathcal{B}_m(Y), \quad g_*([M, f]) = [M, g \circ f]$$

is a covariant functor from the category of topological spaces and continuous maps to the category of R -modules and R -linear maps. That is

$$(g \circ h)_* = g_* \circ h_*$$

$$(\text{id}_X)_* = \text{id}_{\mathcal{B}_m(X)} .$$

\square

In particular if $g : X \rightarrow Y$ is a homeomorphism, then g_* is a R -linear isomorphism with inverse $(g^{-1})_*$. Considered up to linear isomorphism, $\mathcal{B}_m(X)$ is an invariant of the topological type of X . The family introduced above of “forgetting” linear maps

$$\{\sigma_m : \mathcal{B}_m(X; \mathbb{Z}) \rightarrow \mathcal{B}_m(X; \mathbb{Z}/2\mathbb{Z})\}$$

is *functorial*, that is they form commutative squares together with the respective families of g_* ’s; in form of a slogan: “ $g_* \circ \sigma = \sigma \circ g_*$ ”.

10.3. Relative bordism of topological pairs

We consider topological pairs (X, A) where A is a subspace of X and the class \mathcal{M}_m^∂ of compact smooth m -manifolds with boundary $(M, \partial M)$. This incorporates the “absolute situations” by identifying X with the pair (X, \emptyset) and a boundaryless manifold $M \in \mathcal{M}_m$ with (M, \emptyset) .

A *relative singular m -manifold in (X, A)* is a continuous map of pairs

$$f : (M, \partial M) \rightarrow (X, A)$$

where by definition $f(\partial M) \subset A$ and $(M, \partial M) \in \mathcal{M}_m^\partial$. We set $\mathcal{M}_m(X, A)$ the collection of such relative singular m -manifolds.

DEFINITION 10.6. $f : (M, \partial M) \rightarrow (X, A)$ is a *relative singular boundary* if there are continuous pair maps $F : (W, V) \rightarrow (X, A)$, $\rho : (M, \partial M) \rightarrow (Z, \partial Z)$ such that:

- (1) $(W, \partial W) \in \mathcal{M}_{m+1}^\partial$;
- (2) $(V, \partial V)$ and $(Z, \partial Z)$ are smooth m -submanifolds of ∂W such that

$$\partial W = V \cup Z, \quad V \cap Z = \partial V = \partial Z ;$$

- (3) $\rho : (M, \partial M) \rightarrow (Z, \partial Z)$ is a smooth diffeomorphism (preserving the orientation in the oriented case). In particular if ∂M is empty, then V and Z are also boundaryless, $\partial W = V \amalg Z$ and $F(V) \subset A$.

We put on $\mathcal{M}_m(X, A)$ the equivalence relation $(M_0, \partial M_0, f_0) \sim_{\mathcal{B}} (M_1, \partial M_1, f_1)$ if and only if $(M_0, \partial M_0, f_0) \amalg (-M_1, \partial M_1, f_1)$ is a relative singular boundary (in the unoriented case the sign “ $-$ ” is immaterial). The verification that it is an equivalence relation (in particular the transitivity) incorporates some instances of corner smoothing, accordingly with Remark 7.16.

The disjoint union on $\mathcal{M}_m(X, A)$ descends to a operation $+$ on the quotient set that eventually makes it a R -module $\mathcal{B}_m(X, A) = \mathcal{B}_m(X, A; R)$, called the *relative m -bordism R -module* of the topological pair (X, A) .

Proposition 10.5 extends directly:

PROPOSITION 10.7. *For every $m \geq 0$,*

$$(X, A) \Rightarrow \mathcal{B}_m(X, A)$$

$g : (X, A) \rightarrow (Y, B) \Rightarrow g_* : \mathcal{B}_m(X, A) \rightarrow \mathcal{B}_m(Y, B)$, $g_*([M \partial M, f]) = [M, \partial M, g \circ f]$ is a covariant functor from the category of pairs of topological spaces and continuous pair maps to the category of R -modules and R -linear maps.

10.4. On Eilenberg-Steenrod axioms

The singular homology (sometimes called “Betti homology”) with coefficients in the ring R is a determined family of functors (indexed by $m \geq 0$) of the same kind of Propositions 10.5, 10.7. The (E-S)-axioms are abstractions of some properties verified by the singular homology functors and which deserve the name because all models (no matter how they have been produced) that fulfill such axioms are isomorphic to each other, at least if one restricts to pairs of compact CW-complexes (see [Hatch]). It turns out that the most critical one is the so called *dimension axiom*; every model which verifies the other axioms (with the possible exception of “dimension”) is called a *generalized homology theory*. We are going to check that this is the case of bordism. The verifications are of geometric/topological nature and often immediate consequences of the definitions.

The homotopy axiom. *If $g_0, g_1 : (X, A) \rightarrow (Y, B)$ are homotopic through pair maps, then $g_{0,*} = g_{1,*}$.*

We have to show that for every $[M, \partial M, f] \in \mathcal{B}_m(X, A)$,

$$[M, \partial M, g_0 \circ f] = [M, \partial M, g_1 \circ f] \text{ in } \mathcal{B}_m(Y, B) .$$

Given a homotopy

$$G : (X \times [0, 1], A \times [0, 1]) \rightarrow (Y, B)$$

between g_0 and g_1 , then

$$F : (M \times [0, 1], \partial M \times [0, 1]) \rightarrow (Y, B), \quad f_t = g_t \circ f$$

together with the natural inclusion of $(M, \partial M) \amalg (M, \partial M)$ in $\partial(M \times [0, 1])$ realize that $(M, \partial M, g_0 \circ f) \sim_{\mathcal{B}} (M, \partial M, g_1 \circ f)$.

□

This implies that if $g : (X, A) \rightarrow (Y, B)$ is a relative homotopy equivalence, then g_* is a R -linear isomorphism. Up to isomorphism, *the bordism modules are invariants of the homotopy type rather than the topology type.*

Direct sum over path connected components. For every topological space X , $\mathcal{B}_m(X)$ is isomorphic to the direct sum of the modules $\mathcal{B}_m(X_c)$, where X_c varies among the path connected components of X . This follows from the fact that continuous maps send every path connected component of a manifold M into one path connected component of X . A similar fact holds in the relative version.

Long exact sequence. For every $m \geq 1$ there is the natural well defined R -linear map

$$\partial : \mathcal{B}_m(X, A) \rightarrow \mathcal{B}_{m-1}(A), \quad \partial([M, \partial M, f]) = [\partial M, \partial f] .$$

Denote by $i_* : \mathcal{B}_m(A) \rightarrow \mathcal{B}_m(X)$, $j_* : \mathcal{B}_m(X, \emptyset) \rightarrow \mathcal{B}_m(X, A)$ the R -linear maps induced by the inclusions. Then we have a *bordism long sequence* of linear maps

$$\cdots \rightarrow \mathcal{B}_m(A) \xrightarrow{i_*} \mathcal{B}_m(X) \xrightarrow{j_*} \mathcal{B}_m(X, A) \xrightarrow{\partial} \mathcal{B}_{m-1}(A) \rightarrow \cdots$$

which ends on the right with the 0 R -module.

Recall that a sequence of linear maps

$$A \xrightarrow{\alpha} B \xrightarrow{\beta} C$$

is *exact in B* if $\ker(\beta) = \alpha(A)$. Then we have:

- (1) *The long sequences are functorial: if $g : (X, A) \rightarrow (Y, B)$ then the respective long sequences together with the family of linear maps $\{g_*\}$ form commutative squares.*
- (2) *Every bordism long sequence is exact everywhere.*

Factoriality is immediate consequence of the definitions. The verifications of exactness are simple and useful exercises. Let us show for example that the above long sequence is exact in $\mathcal{B}_m(X, A)$. If $[N, g] \in \mathcal{B}_m(X)$ then N is boundaryless, so it is clear that $\partial \circ j_*([N, g]) = 0 \in \mathcal{B}_{m-1}(A)$. On the other hand, If $(M, \partial M, f)$ is in the kernel of ∂ and $(W, \partial W, F)$ realizes that $(\partial M, \partial f)$ is a boundary, then by gluing W and M along ∂M , we get $\tilde{f} : \tilde{M} \rightarrow X$, \tilde{M} being boundaryless, \tilde{f} obtained by matching f and F , such that $j_*([\tilde{M}, \tilde{f}]) = [M, \partial M, f] \in \mathcal{B}_m(X, A)$. □

Excision. Let $Z \subset A \subset X$ be a triad of topological space. Assume that the closure \bar{Z} of Z in X is contained in the interior \mathring{A} of A . Then we have

For every $m \geq 0$, the linear map induced by the inclusion

$$i_* : \mathcal{B}_m(X \setminus Z, A \setminus Z) \rightarrow \mathcal{B}_m(X, A)$$

is an isomorphism. We say that Z is excisable.

Let us prove first that it is surjective. Let $[M, \partial M, f] \in \mathcal{B}_m(X, A)$. The manifold M can be endowed with a distance d compatible with its topology so that (M, d) is a compact metric space; for example embed M in some \mathbb{R}^n and take the distance induced by the euclidean distance. $K := f^{-1}(\bar{Z})$ is a compact set contained in the open set $\mathring{A} := f^{-1}(\mathring{A})$. The distance function from K

$$\delta : M \rightarrow \mathbb{R}$$

is non negative, continuous and $K = \{\delta = 0\}$. Then there is a smooth approximation say $g : M \rightarrow \mathbb{R}$ and a regular value $\epsilon > 0$ of both g and ∂g , sufficiently close to 0, such that $\tilde{M} := \{g \geq \epsilon\}$ is a compact m -submanifold with corners such that $\partial \tilde{M} = \{g = \epsilon\}$ is contained in \mathring{A} . Up to smoothing the corners, if \tilde{f} is the restriction of f to \tilde{M} , we finally have that $[\tilde{M}, \partial \tilde{M}, \tilde{f}] \in \mathcal{B}_m(X \setminus Z, A \setminus Z)$ and $i_*([\tilde{M}, \partial \tilde{M}, \tilde{f}]) = [M, \partial M, f] \in \mathcal{B}_m(X, A)$. To prove the injectivity we apply the

same argument to $(W, \partial W, F)$ which realizes that a $(M, \partial M, f) \in \mathcal{M}_m(X \setminus Z, A \setminus Z)$ is a relative singular boundary in (X, A) . \square

About the dimension axiom. This axiom for the singular homology (with coefficients in R) determines the homology modules of a singleton. Precisely, the 0-module is isomorphic to R , while the others are all trivial.

For every X , $\mathcal{B}_0(X)$ has a clear topological meaning. In fact, by using the classification of compact 1-manifolds (Proposition 9.14), it is easy to check that it is isomorphic to the direct sum $\bigoplus_{\pi_0(X)} R$, where $\pi_0(X)$ is the set of path connected components of X . In particular $\mathcal{B}_0 = R$.

On the other hand, we do not know for the moment if the modules \mathcal{B}_m , $m > 1$ are all trivial. In fact we will see in Section 14.8 that *they are not*.

The (E-S)-axioms establish in more or less explicit way relations between the modules $\mathcal{H}_*(X)$ in any (generalized) homology theory of a given space and the ones of the presumably simpler pieces of some suitable decomposition of X . If also “dimension” holds, then in many cases they allow to compute (up to linear isomorphism) the modules of X . Without “dimension” things are more complicated. The first interesting cases to face are $X = S^n$ or the pair $(X, A) = (D^n, S^{n-1})$. These are the building blocks of CW-complexes.

- As the n -disk is contractible for every $n \geq 0$, by “homotopy” $\mathcal{H}_m(D^n) \sim \mathcal{H}_m$ for every $m \geq 0$.

- For every $n \geq 1$, we can decompose S^n as the union of the closed northern and southern hemispheres (both diffeomorphic to D^n)

$$S^n = D^+ \cup D^-, \quad D^+ \cap D^- = S^{n-1} .$$

We claim that the inclusion induces isomorphisms

$$i_* : \mathcal{H}_m(D^+, S^{n-1}) \rightarrow \mathcal{H}_m(S^n, D^-) .$$

We cannot apply directly “excision” to $Z = \mathring{D}^-$. We can do it by using instead $\tilde{Z} \subset D^-$ equal to the complement of a small collar of S^{n-1} in D^- . Finally we use “homotopy” and the fact that $(S^n \setminus \tilde{Z}, D^- \setminus \tilde{Z})$ retracts to (D^+, S^{n-1}) to achieve the required isomorphisms.

- Again for $n \geq 1$, we have the exact long sequence of the pair (D^n, S^{n-1})

$$\cdots \rightarrow \mathcal{H}_m(S^{n-1}) \xrightarrow{i_*} \mathcal{H}_m(D^n) \xrightarrow{j_*} \mathcal{H}_m(D^n, S^{n-1}) \xrightarrow{\partial} \mathcal{H}_{m-1}(S^{n-1}) \rightarrow \cdots$$

and the one of the pair (S^n, D^-)

$$\cdots \rightarrow \mathcal{H}_m(D^-) \xrightarrow{i_*} \mathcal{H}_m(S^n) \xrightarrow{j_*} \mathcal{H}_m(S^n, D^-) \xrightarrow{\partial} \mathcal{H}_{m-1}(D^-) \rightarrow \cdots$$

- If the theory \mathcal{H} verifies also “dimension”, by simple algebraic considerations one realizes that for $n \geq 1$,

- $\partial : \mathcal{H}_m(D^n, S^{n-1}) \rightarrow \mathcal{H}_{m-1}(S^{n-1})$ is an isomorphism for $m \geq 2$;
- $j_* : \mathcal{H}_m(S^n) \rightarrow \mathcal{H}_m(S^n, D^-)$ is an isomorphism for $m \geq 2$;
- for every $m \geq 1$, $\mathcal{H}_m(S^n) \sim \mathcal{H}_{m-1}(S^{n-1})$ (immediately for $m \geq 2$, with a little extrawork for $m = 1$).

Then by a simple induction we can finally achieve the computation:

For every $n \geq 1$, $m = 0, n$,

$$\mathcal{H}_m(S^n) \sim \mathcal{H}_m(D^n, S^{n-1}) \sim R .$$

For every $n \geq 1$, $m \geq 1$, $m \neq n$,

$$\mathcal{H}_m(S^n) \sim \mathcal{H}_m(D^n, S^{n-1}) = 0 .$$

If the theory (like the bordism) does not verify “dimension” the considerations based on the other axioms hold as well but are not immediately conclusive.

10.5. Bordism non triviality

By combining the axioms with the specific way the bordism has been defined, we will provide a few evidences that it is not trivial.

- Assume that X is path connected. Consider the long exact sequence of a pair (X, x_0) for some base point in X ,

$$\cdots \rightarrow \mathcal{B}_m \xrightarrow{i_*} \mathcal{B}_m(X) \xrightarrow{j_*} \mathcal{B}_m(X, x_0) \xrightarrow{\partial} \mathcal{B}_{m-1} \rightarrow \cdots$$

it is immediate by the bordism definition that $\partial = 0$ (hence j_* is onto) and that i_* is injective. Hence every $\mathcal{B}_m(X)$ contains a submodule isomorphic to \mathcal{B}_m which in general is not trivial. Note that since X is path connected, by “homotopy” this submodule does not depend on the choice of the base point x_0 . When $R = \mathbb{Z}/2\mathbb{Z}$ (algebra is simpler in the case of vector spaces) we have $\eta_m(X) \sim \eta_m \oplus \eta_m(X, x_0)$.

- Assume that X is a compact connected boundaryless (possibly oriented) smooth m -manifolds. Then by the approximation theorems of continuous maps by smooth maps, *it is not restrictive to assume that all maps entering the bordism treatment are smooth.* We have

PROPOSITION 10.8. $[X, \text{id}_X] \in \mathcal{B}_m(X)$ is non trivial and does not belong to $\mathcal{B}_m \subset \mathcal{B}_m(X)$. In particular $\dim \eta_m(X) \geq 1 + \dim \eta_m$.

Proof : Assume that it is trivial; then there is a smooth map $F : W \rightarrow X$, such that $\partial W = X$ and $F|_X = \text{id}_X$. Let $p \in X$. Clearly it is a regular value for ∂F . Apply to F the transversality theorems relatively to ∂F . Then we can assume that $F \pitchfork \{p\}$, $Y = F^{-1}(p)$ is a proper 1-submanifold of (W, X) and $p \in Y$. By the classification of compact smooth 1-manifolds, p is contained in an interval component $I \subset Y$, hence there is another $p' \in \partial I \subset X$ such that $p' \neq p$ and $\partial F(p) = p = \partial F(p') = p'$. This is absurd. This proves that $[X, \text{id}_X] \neq 0$. Let $c : N \rightarrow \{p\}$ be a constant map representing some element of $\mathcal{B}_m \subset \mathcal{B}_m(X)$. Let $q \neq p$ so that it is a regular value for both id_X and c . If (W, F) would realize a bordism between (X, id_X) and (N, c) , by applying again the relative first transversality theorem to (W, F) we should deduce that $\partial F^{-1}(q) = \{q\}$ is a boundary; again by the classification of compact 1-manifolds this is absurd.

□

By a similar argument, we have the following generalization.

PROPOSITION 10.9. In the setting of Proposition 10.8 Let $[N] \in \mathcal{B}_k$ be non trivial, and consider $(N \times X, \text{id}_X \circ \pi)$, π being the projection to X . Then $[N \times X, \text{id}_X \circ \pi] \in \mathcal{B}_{m+k}(X)$ is non trivial.

□

The class $[X, \text{id}_X] \in \mathcal{B}_m(X)$ is called the bordism *fundamental class* of the (possibly oriented) manifold X . If X has non empty boundary similar facts hold for $[X, \partial X, \text{id}_X] \in \mathcal{B}_m(X, \partial X)$.

- (On the bordism modules of spheres) For every $n \geq 1$, consider $X = S^n$ or (D^n, S^{n-1}) as above. If $m < n$, by transversality we can assume that every class α in $\mathcal{B}_m(S^n)$ is represented by a smooth and non surjective map $f : M \rightarrow S^n$; say that $\infty \notin f(M)$. Then f factorizes through $\mathbb{R}^n \subset \mathbb{R}^n \cup \infty = S^n$, hence it is homotopic to a constant map. By “homotopy” α belongs to $\mathcal{B}_m \subset \mathcal{B}_m(S^n)$, hence if $m < n$, $\mathcal{B}_m(S^n) = \mathcal{B}_m$.

Referring to the long exact sequence for the pair (S^n, D^-) , using that D^- is contractible and “homotopy”, we have that $\partial = 0$ so that j_* is onto; and i_* is

injective. In particular we have

$$\eta_m(S^n) \sim \eta_m \oplus \eta_m(S^n, D^-) \sim \eta_m \oplus \eta_m(D^n, S^{n-1})$$

where for the last isomorphism we have applied “excision” and “homotopy” as above.

Referring to the long exact sequence for the pair (D^n, S^{n-1}) , we see that i_* is onto, hence $j_* = 0$, ∂ is injective. Hence we have in particular that

$$\eta_{m-1}(S^{n-1}) \sim \eta_{m-1} \oplus \eta_m(D^n, S^{n-1}) ;$$

hence

$$\eta_{m-1}(S^{n-1}) \oplus \eta_m \sim \eta_m(S^n) \oplus \eta_{m-1} .$$

By a similar inductive argument already used to compute $\mathcal{H}_*(S^n)$ when the theory \mathcal{H} verifies also “dimension”, we can eventually achieve the determination of $\eta_*(S^n)$.

- PROPOSITION 10.10. (1) For every $m \geq 0$, $\eta_m(S^0) = \eta_m \oplus \eta_m$.
 (2) For every $n \geq 1$, for every $0 \leq m < n$, $\eta_m(S^n) = \eta_m$.
 (3) For every $n \geq 1$, $k \geq 1$,

$$\eta_{n+k}(S^n) = \eta_k \oplus \eta_{n+k} .$$

Precisely every class in $\eta_{n+k}(S^n)$ either belongs to η_{n+k} or is of the form $[N \times S^n, \text{id}_{S^n} \circ \pi]$ as in Proposition 10.9

□

It is already clear from these few remarks that the determination of \mathcal{B}_m , for every $m \geq 0$, that is of the actual failure of “dimension” is a key point of this story.

10.6. Relation between bordism and homotopy group functors

Here we assume some familiarity with the homotopy group $\pi_m(X, x_0)$, $m \geq 1$, of the *pointed* topological space (X, x_0) (see for instance [Hatch]). When $m = 1$ it is called the *fundamental group*. Let us recall anyway a few facts.

- As a set $\pi_m(X, x_0)$ is formed by the classes $\langle f \rangle$ of pointed continuous maps $f : (S^m, p) \rightarrow (X, x_0)$ considered up to pointed homotopy. It is endowed with a natural group operation “.” well defined on any given representatives. The 1 element is the class of the constant pointed map. They are abelian for $m \geq 2$ while the fundamental group is not in general. If X is path connected, up to group isomorphism they do not depend on the choice of the base point.

- Similarly to the bordism, we have for every $m \geq 1$ a covariant functor

$$(X, x_0) \Rightarrow \pi_m(X, x_0)$$

$$g : (X, x_0) \rightarrow (Y, y_0) \Rightarrow g_* : \pi_m(X, x_0) \rightarrow \pi_m(Y, y_0), \quad g_*(\langle f \rangle) = \langle g \circ f \rangle$$

from the category of pointed topological spaces and pointed continuous maps to the category of groups (abelian for $m \geq 2$) and group homomorphisms.

- There is a relative version for pointed pairs (X, A, x_0) ($x_0 \in A$) of topological spaces. Then the elements of $\pi_m(X, A, x_0)$ are relative homotopy classes $\langle f \rangle$ of maps $f : (D^m, S^{m-1}, p) \rightarrow (X, A, x_0)$. As usual the “absolute” theory is incorporated by identifying (X, x_0) with (X, x_0, x_0) . If $A \neq \{x_0\}$, then $\pi_m(X, A, x_0)$ is abelian for $m \geq 3$. Similarly to the bordism, for every $m \geq 2$ there is a natural homomorphism

$$\partial : \pi_m(X, A, x_0) \rightarrow \pi_{m-1}(A, x_0), \quad \partial(\langle f \rangle) = \langle \partial f \rangle .$$

Together with the homomorphisms

$$i_* : \pi_m(A, x_0) \rightarrow \pi_m(X, x_0), \quad j_* : \pi_m(X, x_0) \rightarrow \pi_m(X, A, x_0)$$

induced by the inclusions, they give rise to the homotopy long exact sequence of the pointed pair (X, A, x_0)

$$\cdots \rightarrow \pi_m(A, x_0) \xrightarrow{i_*} \pi_m(X, x_0) \xrightarrow{j_*} \pi_m(X, A, x_0) \xrightarrow{\partial} \pi_{m-1}(A, x_0) \rightarrow \cdots$$

For every $m \geq 1$ it is well defined the map (in the oriented case we stipulate that D^m inherits the standard orientation of \mathbb{R}^m)

$$h_m : \pi_m(X, A, x_0) \rightarrow \mathcal{B}_m(X, A), \quad h_m(\langle f \rangle) = [D^m, S^{m-1}, f]$$

obtained by “forgetting the base points”. It is well defined because homotopy is a special case of bordism where only the cylinders are permitted. In fact

PROPOSITION 10.11. (1) For every $m \geq 1$, h_m is a group homomorphism.

(2) The family of homomorphisms $\{h_m\}$ is functorial, in a slogan: “ $g_* \circ h = h \circ g_*$ ”, and commutes with the respective long exact sequences.

Proof : Both the respective morphisms g_* and long exact sequences have the very same definition on representatives. Then (2) follows because the h ’s are well defined. As for (1), for simplicity we consider the absolute case $m = 1$, but the argument generalizes without difficulty. Realize an elementary bordism W between $S^1 \amalg S^1$ and S^1 obtained by attaching a 1-handle to $(S^1 \amalg S^1) \times [0, 1]$ along $(S^1 \amalg S^1) \times \{1\}$. There is a properly embedded arc $D \sim D^1$ (essentially the core of the handle) which intersects $(S^1 \amalg S^1) \times \{0\}$ at two points belonging to different components and a properly embedded arc D' dual to D (essentially the co-core of the handle) which intersects the other component of ∂W in two points. $W \setminus (D \cup D')$ is diffeomorphic to the cylinder $C := ((S^1 \setminus \{p\}) \amalg (S^1 \setminus \{p\})) \times [0, 1]$. Let $f_0, f_1 : (S^1, p) \rightarrow (X, x_0)$. Up to the natural identification, this induces a map $F : C \rightarrow X$, $F(x, t) := f_0 \amalg f_1(x)$ which extends to a continuous map $F : W \rightarrow X$, by setting it constantly equal to x_0 on $D \cup D'$. This establishes a bordism between $(S^1, f_0) \amalg (S^1, f_1)$ and a determined map $g : S^1 \rightarrow X$. Recalling the definition of the operation on $\pi_1(X, x_0)$ (see [Hatch]) it is immediate that

$$[S^1, g] = h_1(\langle f_0 \rangle \cdot \langle f_1 \rangle)$$

hence

$$h_1(\langle f_0 \rangle \cdot \langle f_1 \rangle) = h_1(\langle f_0 \rangle) + h_1(\langle f_1 \rangle)$$

as desired. □

In general the study of both $\ker(h_m)$ and its image is a difficult question, even if X is a compact smooth manifold. We can say something more for $m = 1$.

On the 1-bordism. It is evident that the homomorphism

$$\sigma_1 : \Omega_1(X) \rightarrow \eta_1(X)$$

is surjective: given $[M, f]$ in $\eta_1(X)$ it is enough to arbitrarily orient the components of M (each diffeomorphic to S^1) to get $[\tilde{M}, f]$ in $\Omega_1(X)$ such that $\sigma_1([\tilde{M}, f]) = [M, f]$. We have

PROPOSITION 10.12. Assume that X is path connected. Then the homomorphism $h_1 : \pi_1(X, x_0) \rightarrow \Omega_1(X)$ is surjective, hence the oriented bordism $\Omega_1(X)$ is a abelian quotient group of $\pi_1(X, x_0)$. By composition with the surjective homomorphism σ_1 , the same fact holds for $\eta_1(X)$.

Proof : Let $[S^1, f] \in \Omega_1(X)$. Let $p \in S^1$ the base point, $q = f(p)$. Up to isotopy, hence up to bordism, we can assume that f is constantly equal to q on a closed interval $p \in J \subset S^1$. Let $J = J_1 \cup J_2$, $J_1 \cap J_2 = \{p\}$. Let $\gamma_i : J_i \rightarrow X$ be a continuous path joining q and the base point x_0 and such that $\gamma_i(p) = x_0$. Then define $f' : (S^1, p) \rightarrow (X, x_0)$ to be equal to γ_i on J_i and equal to f outside J . Clearly $[S^1, f']$ belongs to the image of h_1 . We claim that $[S^1, f] = [S^1, f']$. In fact

it is not hard to prove that they are homotopic. For a general $[M, f]$ we can assume that M is union of a finite number of copies S_j^1 , of S^1 . Consider the corresponding pointed copies (S_j^1, p_j) . Let $q_j = f(p_j)$. By applying the above construction for every j , we can assume that $[M, f]$ is the sum of classes each one being the image via h_1 of some $\alpha_j \in \pi_1(X, x_0)$. Finally by applying inductively on the number of components the same argument used above to show that h_1 is a homomorphism, we conclude that $[M, f]$ is the image of the product of such α_j 's. \square

We will complete the analysis of $\Omega_1(X)$ as a quotient of the fundamental group in Chapter 15, Proposition 15.3.

10.7. Bordism categories

There is another important way to organize bordism matter. As usual \mathcal{M}_m either denotes \mathcal{S}_m or \mathcal{O}_m , \mathcal{B} either denotes η or Ω . For every $m \geq 0$, we define the *bordism category* $\mathbf{CAT}_{\mathcal{B}}(m+1)$.

- \mathcal{M}_m is the class of *objects* (recall that also \emptyset is an object).
- For every couple of objects $M, N \in \mathcal{M}$, a *morphism* (“arrow”) $M \mapsto N$ is of the form

$$([\rho_0], [\rho_1], [W, V_0, V_1])$$

where (W, V_0, V_1) is a triad of compact smooth manifolds (recall that V_0 and V_1 are union of components of ∂W , and $\partial W = V_0 \amalg V_1$) considered up to diffeomorphisms which are isotopic to the identity on a neighbourhood of the boundary; $\rho_0 : M \rightarrow V_0$ and $\rho_1 : N \rightarrow V_1$ are diffeomorphisms (preserving the orientation in the oriented setting) considered up to isotopy.

- Two arrows $f : M \mapsto N$, $g : M' \mapsto N'$ can be composed if $N = M'$. In such a case if $f = ([\rho_0], [\rho_1], [W, V_0, V_1])$, $g = ([\rho'_0], [\rho'_1], [W', V'_0, V'_1])$ then

$$g \circ f = ([\rho_0], [\rho'_1], [\tilde{W}, V_0, V'_1])$$

where

$$\tilde{W} = W \amalg_{\psi} W', \quad \psi = \rho'_0 \circ \rho_1^{-1} : V_1 \rightarrow V'_0.$$

It is consistent because \tilde{W} obtained by gluing is defined up to diffeomorphism relatively to the boundary and only depends on the isotopy class of the gluing diffeomorphism. Note again that gluing can be performed in the oriented setting.

- For every object $M \in \mathcal{M}_m$, $M \neq \emptyset$, the *unit arrow* is

$$1_M = ([\text{id}_M], [\text{id}_M], [M \times [0, 1], M \times \{0\}, M \times \{1\}]).$$

The discussion made in Chapter 9 about Morse functions on triads, dissections and handle-decompositions can be rephrased within the bordism category: every arrow is composition of *elementary arrows* that is supported by triads admitting a handle decomposition with only one handle (of some index).

10.8. A glance to TQFT

A $(m+1)$ *topological quantum field theory* (TQFT) is a kind of non trivial representation of $\mathbf{CAT}_{\mathcal{B}}(m+1)$ in the category of vector spaces on some scalar field K . In last decades this has emerged as a potent paradigm, the source of a plenty of so called “quantum invariants” for 3-dimensional manifolds and the right conceptual framework for deep 4-dimensional invariants. The actual categorial definition involves many subtleties and is technically quite demanding (see for instance [Tur]). Here we limit to a rough outline of the main features.

First we note that the objects \mathcal{M}_m of a bordism category are endowed with the disjoint union operation “ \amalg ”.

Let K be a field and denote by \mathcal{V}_K the category having as objects the class V_K of *finite dimensional* K -vector spaces and as morphisms the K -linear maps. Also V_K is endowed with an operation “ \otimes ” given by the tensor product.

A $(m + 1)$ TQFT is a morphism of categories

$$\mathbf{CAT}_{\mathcal{B}}(m + 1) \Rightarrow \mathcal{V}_K$$

which verifies certain conditions:

- To every object $M \in \mathcal{M}_m$ is associated an object $Z(M) \in V_K$.
- To every arrow $f : M \mapsto N$ in $\mathbf{CAT}_{\mathcal{B}}(m + 1)$ is associated a linear map $Z(f) : Z(M) \rightarrow Z(N)$, in such a way that the composition is respected:

$$Z(g \circ f) = Z(g) \circ Z(f) .$$

- The correspondence $M \Rightarrow Z(M)$ respects the operations on the objects:

$$Z(M \amalg N) = Z(M) \otimes Z(N) .$$

Moreover there are the following ‘non triviality requirements’:

- $Z(\emptyset) = K$ (the space of “states” of the “quantum” empty set is non trivial).
- $Z(1_M) = \text{id}_{Z(M)}$.
- $Z(M)$ is not constantly equal to K and $Z(f)$ is not constantly equal to id_K .

In the oriented setting, on \mathcal{O}_m there is the involution $M \rightarrow -M$. On V_K there is the duality “involution” $Z \rightarrow Z^*$ (where Z is canonically identified with its bidual space $(Z^*)^*$). Then here we require also

- $Z(-M) = Z(M)^*$.

One realizes quickly that the existence of such TQFT is not evident at all. A possible attack could be to associate to all connected $M \in \mathcal{S}_m$ (possibly equipped with one fixed orientation) a same vector space $Z(M) = V$ (so that $Z(-M) = V^*$ in the oriented setting). As every M is the disjoint union of its connected components, $Z(M)$ is the tensor product of some copies of V or V^* . Then one could try to define first the elementary $Z(e)$ associated to the elementary arrows in $\mathbf{CAT}_{\mathcal{B}}(m + 1)$, perhaps in such a way that they depend only on the handle index. A generic $Z(f)$ should be necessarily a composition of such elementary morphisms. The key hard point is that the decomposition by elementary arrows in $\mathbf{CAT}_{\mathcal{B}}(m + 1)$ is far to be unique (as well as any triad supports a plenty of Morse functions) but the resulting composite $Z(f)$ should not depend on the choice of the decomposition. This means that our elementary $Z(e)$ ’s must verifies a huge collection of (a priori implicit) relations. For instace if we take $V = K^n$ for some n , $V^* = M(1, n, K)$, the unknown $Z(e)$ ’s in matrix form, we should find non trivial solutions of a huge system of matrix equations. It is not evident that such a solution exists (even if we take $V = K$).

Every TQFT (if any) associates to every $M \in \mathcal{M}_{m+1}$, a scalar $\mu(M)$ which is *an invariant up to (possibly oriented) diffeomorphism*. In fact as M is compact and boundaryless, $(\emptyset, \emptyset, [M, \emptyset, \emptyset])$ is an arrow $f_{[M]} : \emptyset \mapsto \emptyset$, then $Z(f_{[M]}) : K \rightarrow K$ and $\mu([M]) := Z(f_{[M]})(1)$.

We will point out a “baby” (non trivial) TQFT in Chapter 14.

Smooth cobordism

We specialize the bordism modules $\mathcal{B}_m(X, R)$ introduced in Chapter 10 to X which varies among the boundaryless compact smooth manifolds. More precisely if X is *not oriented* (even *non orientable*), then we consider $\eta_m(X) = \mathcal{B}_m(X; \mathbb{Z}/2\mathbb{Z})$, if X is *oriented*, we consider $\Omega_m(X) = \mathcal{B}_m(X; \mathbb{Z})$. A first important fact, already used in Section 10.5, is that by means of the approximation theorems of continuous by smooth maps, we can assume that all maps entering the definition of the bordism modules are smooth; moreover, in dealing with functoriality we can also assume that the maps $g : X \rightarrow Y$ are smooth. So all discussion will have a differential/topological character. The main issue of this chapter is that by means of transversality these “smooth” bordism modules (renamed “cobordism” modules up to a suitable reindexing) can be embodied into *contravariant functors* and their direct sum can be endowed with a functorial *graded ring* structure. This multiplicative structure is a substantial enrichment of the theory and will lead to several important applications.

11.1. Map transversality

We consider the following variant of the basic transversality setting (Section 8.1):

- All involved smooth manifolds admit an embedding in some \mathbb{R}^n being furthermore a closed subsets. This is certainly the case if a manifold is compact.
- All involved smooth maps are *proper* (i.e. the inverse image of a compact set is compact). Of course this is the case if the source manifold is compact. General topology tells us that proper maps between manifolds are *closed* (i.e. the image of a closed set is closed).
- N and Z are boundaryless smooth manifolds, M is a compact smooth manifold with (possibly empty) boundary ∂M .
- $f : M \rightarrow N$, $g : Z \rightarrow N$ are smooth maps.

In such a situation, we can define the product map

$$(f \times g) : M \times Z \rightarrow N \times N, (f \times g)(x, z) = (f(x), g(z))$$

and denote by

$$\Delta_N = \{(y, y) \in N \times N\}$$

the *diagonal submanifold* of $N \times N$, which is obviously diffeomorphic to N by the canonical diffeomorphism

$$N \rightarrow \Delta_N, y \rightarrow (y, y).$$

Recall that $\partial(M \times Z) = \partial M \times Z$.

DEFINITION 11.1. We say that f is *transverse to g* (and we write $f \pitchfork g$) if $(f \times g) \pitchfork \Delta_N$. This incorporates that $\partial f \pitchfork g$.

By using that $T_{(y,y)}\Delta_N = \Delta_{T_y N} \subset T_y N \oplus T_y N$ one readily checks that:

LEMMA 11.2. $f \pitchfork g$ if and only if for every $(x, z) \in M \times Z$ such that $f(x) = g(z) = y$, then $T_y N = d_x f(T_x M) + d_z g(T_z Z)$, and for every $(x, z) \in \partial M \times Z$ such that $\partial f(x) = g(z) = y$, then $T_y N = d_x \partial f(T_x \partial M) + d_z g(T_z Z)$.

□

We have the following version of the first transversality theorem:

THEOREM 11.3. *In the given setting:*

(1) *If $f \pitchfork g$ then*

$$(Y, \partial Y) = ((f \times g)^{-1}(\Delta_N), (\partial f \times g)^{-1}(\Delta_N))$$

is a compact proper submanifold of $(M \times Z, \partial M \times Z)$. Moreover,

$$\dim(M \times Z) - \dim(Y) = \dim(N \times N) - \dim(N) = \dim(N) .$$

(2) *If all involved manifolds are oriented, then Y and ∂Y are orientable and we can fix an orientation procedure such that ∂Y becomes the oriented boundary of Y .*

Proof : With the exception of the compactness of Y , all statements in (1) are direct consequence of Theorem 8.2 (and they hold also without assuming that g is proper). On the other hand, the compactness of Y follows from the compactness of M and the properness of g . Point (2) is a direct consequence of point (2) of Theorem 8.2, once $N \times N$ is endowed with the product orientation of two copies of the given orientation on N , Δ_N is oriented in such a way that the canonical diffeomorphism is orientation preserving.

□

REMARK 11.4. If $Z \subset N$ is a submanifold and g is the inclusion, then

$$Y = \{(x, z) \in M \times Z; f(x) = z\}$$

that is the graph of the restriction of f to $f^{-1}(Z)$. If Z is also a closed subset of N , then we are in the setting fixed above, and the projection of Y in M is equal to $f^{-1}(Z)$ and is a proper submanifold of $(M, \partial M)$ recovering the conclusion of Theorem 8.2.

We denote by $\pitchfork(M, N; g)$ the subspace of $\mathcal{E}(M, N)$ formed by the maps transverse to g . If $\partial f \pitchfork g$, then we denote by $\mathcal{E}(M, N, \partial f)$ (resp. $\pitchfork(M, N, \partial f; g)$) the subspace of $\mathcal{E}(M, N)$ ($\pitchfork(M, N; g)$) formed by the maps that coincide with ∂f on ∂M . We have the following version of Theorem 8.5.

THEOREM 11.5. *In the given setting:*

(1) $\pitchfork(M, N; g)$ *is open dense in $\mathcal{E}(M, N)$.*

(2) $\pitchfork(M, N, \partial f; g)$ *is open dense in $\mathcal{E}(M, N, \partial f)$.*

(3) *For every $h \in \mathcal{E}(M, N)$ (resp. $h \in \mathcal{E}(M, N, \partial f)$) there is $\tilde{h} \in \pitchfork(M, N; g)$ ($\tilde{h} \in \pitchfork(M, N, \partial f; g)$) smoothly homotopic to h .*

Proof : The proof is not a direct consequence of the *statement* of Theorem 8.5 but it is a consequence of its proof which can be adapted with minor changes.

□

11.2. Cobordism contravariant functors

Let X be a compact boundaryless smooth manifold. Let $[M, f] \in \mathcal{B}_m(X; R)$ (either $R = \mathbb{Z}/2\mathbb{Z}$ or $R = \mathbb{Z}$ according to the convention fixed at the beginning of the Chapter). Then we say that $[M, f]$ is of *codimension k in X* if

$$k = \text{codim}_X[M, f] := \dim(X) - m .$$

We can consider the modules $\mathcal{B}_m(X; R)$ indexed by \mathbb{Z} by stipulating that $\mathcal{B}_m(X; R) = 0$ if $m < 0$. If k is the codimension, set

$$\mathcal{B}^k(X; R) := \mathcal{B}_m(X; R)$$

so we have a formal reindexing by \mathbb{Z} of the family of bordism modules of X in terms of the codimension, so that $\mathcal{B}^k(X; R) = 0$ if $k > \dim X$. To stress it we say that

$\mathcal{B}^k(X; R)$ is the k -cobordism module of X (over R). Formally for every $k \in \mathbb{Z}$, there are tautological reindexing isomorphisms

$$d : \mathcal{B}_{\dim(X)-k}(X; R) \rightarrow \mathcal{B}^k(X; R), \quad D : \mathcal{B}^k(X; R) \rightarrow \mathcal{B}_{\dim(X)-k}(X; R)$$

$$d(\alpha) = D(\alpha) = \alpha.$$

For every $k \in \mathbb{Z}$ we want to enhance the object correspondence

$$X \Rightarrow \mathcal{B}^k(X; R)$$

with a correspondence

$$g : X \rightarrow Y \Rightarrow g^* : \mathcal{B}^k(Y; R) \rightarrow \mathcal{B}^k(X; R)$$

to build a contravariant functor from the category of compact boundaryless (possibly oriented) smooth manifolds and smooth maps to the category of R -modules and R -linear maps. Hence we want that

$$(g \circ h)^* = h^* \circ g^*$$

whenever the composition makes sense, and

$$\text{id}_X^* = \text{id}_{\mathcal{B}^k(X; R)}.$$

We have to define the induced linear maps g^* . We implement the following procedure, basically it is the same “pull-back” construction that we have used for vector bundles.

- If $k > \dim(Y)$, then $g^* : \{0\} \rightarrow \mathcal{B}^k(X; R)$ is uniquely determined.
- Assume that $k \leq \dim(Y)$ and let $\alpha \in \mathcal{B}^k(Y; R)$. Fix a representative

$$\alpha = [M, f].$$

Hence M is compact boundaryless (possibly oriented) of dimension $m = \dim(Y) - k$. By the transversality theorems, up to homotopy hence up to bordism, we can assume that $f \pitchfork g$. Then

$$V = (f \times g)^{-1}(\Delta_Y)$$

is a compact boundaryless (possibly oriented) submanifold of $M \times X$ such that $\dim(M \times X) - \dim(V) = \dim(Y)$, that is

$$\dim(X) - \dim(V) = \dim(Y) - \dim(M) = k.$$

Hence $[V, p_X] \in \mathcal{B}^k(X; R)$, where p_X is the restriction of the projection $M \times X \rightarrow X$.

We have

PROPOSITION 11.6. *Let $g : X \rightarrow Y$ be a smooth map between compact boundaryless (possibly oriented) smooth manifolds. Let $\alpha \in \mathcal{B}^k(Y; R)$. Let $[V, p_X] \in \mathcal{B}^k(X; R)$ obtained by means of any implementation of the above “pull-back” procedure starting from a representative $\alpha = [M, f]$. Then*

(1) *The map*

$$g^* : \mathcal{B}^k(Y; R) \rightarrow \mathcal{B}^k(X; R), \quad g^*(\alpha) = [V, p_X]$$

is well defined (it does not depend on the arbitrary choices of a given implementation).

(2) *g^* is R -linear.*

(3) *For every X*

$$\text{id}_X^* = \text{id}_{\mathcal{B}^k(X; R)}.$$

(4) *Whenever the composition makes sense*

$$(g \circ h)^* = h^* \circ g^*.$$

(5) *Let $n = \dim X$; if $[X, g_0] = [X, g_1] \in \mathcal{B}_n(Y; R)$, then $g_0^* = g_1^*$. In particular this holds if g_0 and g_1 are homotopic.*

Proof : Assume that g^* is well defined and prove items (2)-(4). The procedure distributes on the addends of a disjoint union so (2) follows easily.

As for (3) Every $[M, f]$ is tranverse to id_X , hence V is the graph of f and clearly $[V, p_X] = [M, f]$.

Concerning (4), If $g^*([M, f]) = [M', f']$, $h^*([M', f']) = [M'', f'']$ the representatives being obtained by iterated application of the pull-back procedure, then $f'' \pitchfork (g \circ h)$ and $[M'', f'']$ results from an implementation of the procedure applied to $[M, f]$ and $g \circ h$.

Let us show now (1), that is g^* is well defined. Let (V, p_X) and (V', p'_X) be obtained by implementing the procedure starting from representatives (M, f) and (M', f') , $f \pitchfork g$, $f' \pitchfork g$; let (W, F) realizes a bordism of (M, f) with (M', f') . By applying the transversality theorems we can assume that $F \pitchfork g$. Then $((F \times g)^{-1}(\Delta_Y), P_X)$ realizes a bordism of (V, p_X) with (V', p'_X) .

Finally (5) follows by the very similar argument used for (1): if (W, F) realizes a bordism of (X, g_0) with (X, g_1) , then we can assume that F verifies suitable transversality conditions, so that $(f \times F)^{-1}(\Delta_Y)$ leads to a bordism of $((f \times g_0)^{-1}(\Delta_Y), p_X)$ with $((f \times g_1)^{-1}(\Delta_Y), p_X)$. □

11.2.1. Reduction mod(2). When X is oriented, we already known the natural “forgetting” homomorphisms

$$\sigma : \mathcal{B}^k(X; \mathbb{Z}) \rightarrow \mathcal{B}^k(X; \mathbb{Z}/2\mathbb{Z}) .$$

These are functorial, that is

PROPOSITION 11.7. *For every smooth map $g : X \rightarrow Y$ between oriented compact boundaryless manifolds, for every $\alpha \in \mathcal{B}^k(Y; \mathbb{Z})$ then $g^*(\sigma(\alpha)) = \sigma(g^*(\alpha))$, where the first g^* refers to the $\mathbb{Z}/2\mathbb{Z}$ -cobordism, the second to the \mathbb{Z} -cobordism.*

Proof : The construction of $g^*(\sigma(\alpha))$ is obtained by the one of $g^*(\alpha)$ just by forgetting the orientation. □

11.3. The cobordism cup product

Let X be as above. For every $r, s \in \mathbb{Z}$, we are going to define a bilinear map

$$\sqcup : \mathcal{B}^r(X; R) \times \mathcal{B}^s(X; R) \rightarrow \mathcal{B}^{r+s}(X; R) .$$

Let us describe the procedure that defines this “cup” product.

- If at least one among r and s is bigger than $\dim(X)$, then $\alpha \sqcup \beta = 0$.

- Let $(\alpha, \beta) \in \mathcal{B}^r(X; R) \times \mathcal{B}^s(X; R)$ and assume that both r and s are $\leq \dim(X)$. Fix representatives $\alpha = [M, f]$ and $\beta = [N, h]$. We claim that

$$[M \times N, f \times h] \in \mathcal{B}^{r+s}(X \times X; R) .$$

In fact

$$2 \dim(X) - (\dim(M) + \dim(N)) = 2 \dim(X) - (\dim(X) - r + \dim(X) - s) = r + s .$$

- Let $\delta_X : X \rightarrow X \times X$, $\delta_X(x) = (x, x)$ be the canonical diffeomorphism onto the diagonal Δ_X . Finally take

$$\delta_X^*[M \times N, f \times h] \in \mathcal{B}^{r+s}(X; R) .$$

We stress that we are actually using the contravariant nature of the cobordism functors.

REMARK 11.8. If $f \pitchfork h$ we can explicitly describe representatives of $\delta_X^*[M \times N, f \times h]$. In fact in such a case $(f \times h) \pitchfork \delta_X$. Then $\delta_X^*[M \times N, f \times h] = [\tilde{V}, p_X]$ where

$$\tilde{V} = \{(x, p, q) \in X \times M \times N; f(p) = h(q) = x\} .$$

Let

$$V = (f \times h)^{-1}(\Delta_X) = \{(p, q) \in M \times N; f(p) = h(q)\} .$$

Then \tilde{V} is the graph of $u := f|_V = h|_V$, V and \tilde{V} are canonically diffeomorphic, and

$$[\tilde{V}, p_X] = [V, u] \in \mathcal{B}^{r+s}(X; R) .$$

In particular if f and h are the inclusions of two transverse submanifolds M and N of X and j is the inclusion of $M \pitchfork N$, then

$$\delta_X^*[M \times N, f \times h] = [M \pitchfork N, j] .$$

We have

PROPOSITION 11.9. *Let X be a compact boundaryless (possibly oriented) smooth manifolds. Let $(\alpha, \beta) \in \mathcal{B}^r(X; R) \times \mathcal{B}^s(X; R)$, $\delta_X^*[M \times N, f \times h] \in \mathcal{B}^{r+s}(X; R)$ be obtained by any implementation of the above procedure applied to arbitrary representatives $\alpha = [M, f]$, $\beta = [N, h]$. Then:*

(1) *The class $\alpha \times \beta := [M \times N, f \times h]$, whence the map $\alpha \sqcup \beta := \delta_X^*[M \times N, f \times h]$ are well defined (they do not depend on the arbitrary choices of a given implementation).*

(2) *\sqcup is bilinear.*

(3) *For every $(\alpha, \beta) \in \mathcal{B}^r(X; R) \times \mathcal{B}^s(X; R)$,*

$$\alpha \sqcup \beta = (-1)^{rs} \beta \sqcup \alpha .$$

(4) *\sqcup is functorial, that is for every $g : X \rightarrow Y$, for every $(\alpha, \beta) \in \mathcal{B}^r(Y; R) \times \mathcal{B}^s(Y; R)$,*

$$g^*(\alpha) \sqcup g^*(\beta) = g^*(\alpha \sqcup \beta) .$$

Proof : Again assume that \sqcup is well defined and prove the other items. By the transversality theorems the assumption allows us to use representatives which verify all suitable transversality conditions. The disjoint union distributes to the product of manifolds; (2) follows easily. Item (3) is a local verification and reduces to Remark 8.3. Let (M, f) , (N, h) be representatives of α and β such that $f \pitchfork g$, $h \pitchfork g$ and $f \pitchfork h$. It follows that $(g \times g) \circ \delta_X \pitchfork (f \times h)$. By combining the two procedures that define g^* and \sqcup starting from such representatives in general position we obtain representatives for both terms of the equality of (4) that are evidently bordant to each other (in the same spirit of Remark 11.8). It remains to prove that \sqcup is well defined. As δ_X^* is well defined, it is enough to show that

$$\alpha \times \beta := [M \times N, f \times h] \in \mathcal{B}^{r+s}(X \times X; R)$$

only depends on the class α and β . By symmetry it is enough to show that it does not depend on the choice of a representative of α . If (W, F) realizes a bordism of (M, f) with (M', f') then $(W \times N, F \times h)$ realizes a bordism of $(M \times N, f \times h)$ with $(M' \times N, f' \times h)$. □

11.3.1. Reduction mod(2). Similarly to Proposition 11.2.1 we have

PROPOSITION 11.10. *For every compact oriented boundaryless manifold X , for every $(\alpha, \beta) \in \mathcal{B}^r(X; \mathbb{Z}) \times \mathcal{B}^s(X; \mathbb{Z})$, $\sigma(\alpha) \sqcup \sigma(\beta) = \sigma(\alpha \sqcup \beta)$, where the first \sqcup refers to the $\mathbb{Z}/2\mathbb{Z}$ -cobordism, the second to the \mathbb{Z} -cobordism.*

Proof : The construction of $\sigma(\alpha) \sqcup \sigma(\beta)$ is obtained by the one of $\alpha \sqcup \beta$ just by forgetting the orientation. □

11.3.2. The cobordism ring. The collection of the above cup products gives a globally defined product

$$\sqcup : \mathcal{B}^\bullet(X; R) \times \mathcal{B}^\bullet(X; R) \rightarrow \mathcal{B}^\bullet(X; R)$$

on the direct sum R -module

$$\mathcal{B}^\bullet(X; R) := \bigoplus_{k \in \mathbb{Z}} \mathcal{B}^k(X; R) .$$

$(\mathcal{B}^\bullet(X; R), +, \sqcup)$ is called the *graded R -cobordism ring of X* (it is a graded algebra when $R = \mathbb{Z}/2\mathbb{Z}$).

Similarly the collection of above g^* 's defines a global graded ring homomorphism

$$g^* : \mathcal{B}^\bullet(Y; R) \rightarrow \mathcal{B}^\bullet(X; R) .$$

We can summarize the above achievements as follows:

$$X \Rightarrow \mathcal{B}^\bullet(X; R)$$

$$g : X \rightarrow Y \Rightarrow g^* : \mathcal{B}^\bullet(Y; R) \rightarrow \mathcal{B}^\bullet(X; R)$$

define a contravariant functor from the category of compact boundaryless (possibly oriented) smooth manifolds and smooth maps to the category of graded rings and graded ring homomorphisms.

REMARK 11.11. A graded ring verifying the *non* commutative rule (3) in Proposition 11.9 is sometimes called a “commutative” graded ring.

REMARK 11.12. A particular case of the above constructions is when X is reduced to one point. In this case the product

$$\mathcal{B}^r(R) \times \mathcal{B}^s(R) \rightarrow \mathcal{B}^{r+s}(R)$$

for every couple of indices $r, s \leq 0$ is just defined by the product of representatives

$$[M] \sqcup [N] = [M \times N] .$$

REMARK 11.13. (*Non compact X*) Referring to the setting of the transversality theorems of Section 11.1, we can extend the range of cobordism functors and product to the category of boundaryless possibly non compact manifolds X but which can be embedded anyway in some \mathbb{R}^k being also a closed subset, and smooth *proper* maps between these manifolds.

11.4. Duality, intersection forms

Assume that X is connected (possibly oriented), $\dim(X) = n$. Then

$$\mathcal{B}^n(X; R) \sim \mathcal{B}_0(X; R) \sim R .$$

If $R = \mathbb{Z}/2\mathbb{Z}$, we have a generator β_X of $\mathcal{B}^n(X; \mathbb{Z}/2\mathbb{Z})$ represented as $\beta_X = [x, i]$ where $x \in X$ and i is the inclusion (it does not depend on the choice of x because X is path connected). If $R = \mathbb{Z}$ we have two generators of the form $[\pm x, i]$. As usual we encode the point sign by associating to $+x$ the orientation on $T_x X$ carried by the global orientation of X and this selects again one generator β_X . By this choice of generators we have fixed in both cases an identification of $\mathcal{B}^n(X; R)$ with R .

For every r, s , set $p = n - r$, $q = n - s$. Let r, s be such that $r + s = n$ (hence also $p + q = n$, $p = s$, $q = r$). Then

$$\sqcup : \mathcal{B}^r(X; R) \times \mathcal{B}^s(X; R) \rightarrow R .$$

Note in particular that

$$d(\alpha_X) \sqcup \beta_X = 1$$

where $\alpha_X = [X, \text{id}_X] \in \mathcal{B}_n(X; R)$ is the bordism fundamental class of X and $d : \mathcal{B}_n(X; R) \rightarrow \mathcal{B}^0(X; R)$ is the tautological isomorphism.

By using the tautological isomorphisms, all this can be lifted to a bilinear map

$$\bullet : \mathcal{B}_p(X; R) \times \mathcal{B}_q(X; R) \rightarrow R$$

or to a bilinear pairing

$$\square : \mathcal{B}^r(X; R) \times \mathcal{B}_q(X; R) \rightarrow R .$$

This last induces a linear map ($q = r$)

$$\phi^r : \mathcal{B}^r(X; R) \rightarrow \text{Hom}(\mathcal{B}_r(X; R), R), \quad \gamma \rightarrow \phi_\gamma, \quad \phi_\gamma(\sigma) = \gamma \square \sigma .$$

Recall that by applying the Hom functors we have a basic way to convert the covariant bordism functors into contravariant ones

$$X \Rightarrow \text{Hom}(\mathcal{B}_m(X; R), R)$$

$$g : X \rightarrow Y \Rightarrow g_*^t : \text{Hom}(\mathcal{B}_m(Y; R), R) \rightarrow \text{Hom}(\mathcal{B}_m(X; R), R)$$

$g_*^t(\gamma) = \gamma \circ g_*$. The homomorphisms ϕ^r , g_*^t and g^* are compatible; in a slogan: “ $\phi^r \circ g^* = g_*^t \circ \phi^r$ ”

The map ϕ^r is in general not injective nor surjective. A reason is the possible existence of non trivial submodules of $\mathcal{B}_*(X; R)$ isomorphic to $\mathcal{B}_* = \mathcal{B}_*(\{x_0\}; R)$. The image via the tautological isomorphism of such submodule in $\mathcal{B}^r(X; R)$ is contained in the kernel of ϕ^r . If $R = \mathbb{Z}/2\mathbb{Z}$, so that \mathcal{B}_r can be realized as a direct addend of $\mathcal{B}_r(X; \mathbb{Z}/2\mathbb{Z})$, then any functional γ which holds 1 on \mathcal{B}_r and such that $\mathcal{B}_r(X; \mathbb{Z}/2\mathbb{Z}) = \mathcal{B}_r \oplus \ker \gamma$ does not belong to the image of ϕ^r . If $R = \mathbb{Z}$, then the *torsion submodule* of $\mathcal{B}^r(X; \mathbb{Z})$ is contained in the kernel of ϕ^r . For every r we set

$$\mathcal{H}^r(X; R) := \mathcal{B}^r(X; R) / \ker(\phi^r)$$

and extending the usual reindexing set

$$\mathcal{H}_{n-r}(X; R) := \mathcal{H}^r(X; R)$$

where in this last equality only the R -module structure is considered, forgetting the multiplicative structure. Then the above map ϕ^r induces an injective R -linear map

$$\hat{\phi}^r : \mathcal{H}^r(X; R) \rightarrow \text{Hom}(\mathcal{H}_r(X; R), R) .$$

If X is connected (possibly oriented), then

$$\mathcal{H}^0(X; R) \sim R$$

and is generated by the fundamental class. The map \square can be formally generalized by composing \square with the tautological isomorphisms

$$\square : \mathcal{B}^r(X; R) \times \mathcal{B}_q(X; R) \rightarrow \mathcal{B}_{2n-(r+q)}(X; R) .$$

In particular

$$\square : \mathcal{B}^r(X; R) \times \mathcal{B}_n(X; R) \rightarrow \mathcal{B}_{n-r}(X; R)$$

and it is a consequence of the definitions that for every $\sigma \in \mathcal{B}^r(X; R)$

$$\sigma \square \alpha_X = D(\sigma) .$$

If $\dim(X) = 2m$ then we can consider

$$\square : \mathcal{B}^m(X; R) \times \mathcal{B}^m(X; R) \rightarrow R$$

or equivalently

$$\bullet : \mathcal{B}_m(X; R) \times \mathcal{B}_m(X; R) \rightarrow R$$

this second is also called the *R-bordism intersection form of X*. Note that these forms are symmetric on $\mathbb{Z}/2\mathbb{Z}$, while on \mathbb{Z} they are symmetric (resp. antisymmetric) if m is even (m is odd). The kernel of ϕ^r coincides in this case with the *radical* of the form, hence the induced form (also called “intersection form”)

$$\square : \mathcal{H}^m(X; R) \times \mathcal{H}^m(X; R) \rightarrow R$$

determines an inclusion of $\mathcal{H}^m(X; R)$ as a submodule of its dual module

$$\hat{\phi}^m : \mathcal{H}^m(X; R) \rightarrow \text{Hom}(\mathcal{H}_m(X; R), R) .$$

11.5. Cobordism theory for compact manifolds with boundary

First let us strengthen the notion of map between pairs of spaces

$$h : (X, A) \rightarrow (Y, B) ;$$

it is a *strict* pair map if (as usual) $h(A) \subset B$ and furthermore $h(X \setminus A) \subset Y \setminus B$.

We consider the category of compact smooth (possibly oriented) manifolds with (possibly empty) boundary $(X, \partial X)$ and smooth strict pair maps

$$h : (X, \partial X) \rightarrow (Y, \partial Y) .$$

For example the inclusion of a *proper* submanifold $(M, \partial M)$ in $(X, \partial X)$ is a typical example of strict map. We stress that a strict map $f : (M, \emptyset) \rightarrow (X, \partial X)$ sends the boundaryless M in the interior $\text{Int}(X)$ of X .

The non compact manifold $\text{Int}(X)$ verifies the conditions of Remark 11.13; for example if $X \subset \mathbb{R}^k$ for some k (this is possible because X is compact) and $h : \mathbb{R}^k \rightarrow \mathbb{R}$ is a non negative smooth function such that $\partial X = h^{-1}(0)$, then the restriction to $X \setminus \partial X$ of $\mathbb{R}^k \setminus \partial X \rightarrow \mathbb{R}^{k+1}$, $x \rightarrow (x, 1/h(x))$ is an embedding of $\text{Int}(X)$ onto a closed subset of \mathbb{R}^{k+1} .

The usual definitions of the absolute or relative bordism modules $\mathcal{B}_m(X; R)$ or $\mathcal{B}_m(X, \partial X; R)$ can be enhanced by stipulating that all involved pair maps are smooth and strict. By using the approximation theorem of continuous maps by smooth maps and the boundary collars to push into the interior what is necessary in order to make strict any given “singular” smooth manifold in X or in $(X, \partial X)$, it is not hard check that:

These enhanced modules are actually isomorphic to the original ones and moreover, $\mathcal{B}_m(X; R)$ is naturally isomorphic to $\mathcal{B}_m(\text{Int}(X); R)$.

The reindexing $\mathcal{B}^k(X; R) = \mathcal{B}_m(X; R)$ or $\mathcal{B}^k(X, \partial X; R) = \mathcal{B}_m(X, \partial X; R)$, $k = \dim(X) - m$ is made as usual with respect to the codimension in X .

Let $g : (X, \partial X) \rightarrow (Y, \partial Y)$ be a smooth strict map in our category. We want to extend the definition of the induced linear morphism

$$g^* : \mathcal{B}^k(Y, \partial Y; R) \rightarrow \mathcal{B}^k(X, \partial X; R) .$$

For every strict pair map $h : (N, \partial N) \rightarrow (Y, \partial Y)$ we denote as usual

$$\partial h : \partial N \rightarrow Y$$

the restriction of h to the boundary; then set

$$\partial \partial h : \partial N \rightarrow \partial Y$$

such that $\partial h = j \circ \partial \partial h$, where j is the inclusion of ∂Y in Y . Close to Lemma 11.2, we say that $(f, \partial f) \pitchfork (g, \partial g)$ if and only if

- (1) for every $(p, x) \in M \times X$ such that $f(p) = g(x) = y$, $T_y Y = d_p f(T_p M) + d_x g(T_x X)$; for every $(p, x) \in \partial M \times X$ such that $\partial f(p) = g(x) = y$, $T_y Y = d_p \partial f(T_p \partial M) + d_x g(T_x X)$; coherently with the notations of Section 11.1, we summarize this item by “ $f \pitchfork g$ ”;
- (2) $g \pitchfork f$;
- (3) $\partial \partial f \pitchfork \partial \partial g$ (in the usual sense).

Let $(M, \partial M, f)$ be a smooth and strict representative of a given $\alpha \in \mathcal{B}^k(Y, \partial Y; R)$. By suitably and straightforwardly adapting the transversality theorems, we can assume that $(f, \partial f) \pitchfork (g, \partial g)$. Set $V = \{(p, x) \in M \times X; f(p) = g(x)\}$. Then

$$g^*(\alpha) := [V, \partial V, p_X]$$

well defines our desired linear map g^* .

Now, by formally using the very same definition given when X is boundaryless, we (partially) extend the cup product as follows:

$$\sqcup : \mathcal{B}^r(X, \partial X; R) \times \mathcal{B}^s(X; R) \rightarrow \mathcal{B}^{r+s}(X; R)$$

$$\sqcup : \mathcal{B}^r(X; R) \times \mathcal{B}^s(X; R) \rightarrow \mathcal{B}^{r+s}(X; R) .$$

Then we have a linear map

$$\phi^r : \mathcal{B}^r(X, \partial X; R) \rightarrow \text{Hom}(\mathcal{B}_r(X; R), R)$$

which restricts to (we keep the same name)

$$\phi^r : \mathcal{B}^r(X; R) \rightarrow \text{Hom}(\mathcal{B}_r(X; R), R) .$$

Finally we have the induced injective map

$$\hat{\phi}^r : \mathcal{H}^r(X, \partial X; R) \rightarrow \text{Hom}(\mathcal{H}_r(X; R), R) .$$

Applications of cobordism rings

In this chapter we will see several, sometimes very classical, applications of the cobordism theory, especially of its multiplicative structure.

12.1. Fundamental class revised, Brouwer's fixed point Theorem

Here we recover Proposition 10.8 in terms of cobordism. Let X be a boundaryless connected (possibly oriented) smooth n -manifold. Let $[X, \text{id}_X] \in \mathcal{B}^0(X; R)$ (often we will simply write $[X]$). Let $\beta_X \in \mathcal{B}^n(X; R)$ the generator given in Section 11.4 in order to fix an identification $\mathcal{B}^n(X; R) = R$. We have already remarked that

$$[X] \sqcup \beta_X = 1 \in R$$

hence in particular $[X] \neq 0$. On the other hand, if γ belongs to the image via the tautological isomorphism $d : \mathcal{B}_n(X; R) \rightarrow \mathcal{B}^0(X; R)$ of the natural submodule isomorphic to \mathcal{B}_n , then

$$\gamma \sqcup \beta_X = 0$$

hence $[X] \neq \gamma$. If X has non empty boundary ∂X , we can consider

$$[X, \partial X] \in \mathcal{B}^0(X, \partial X; R)$$

and we have again

$$[X, \partial X] \cup \beta_X = 1 \in R .$$

The following is a very classical topological application of such a fundamental class.

THEOREM 12.1. (Brouwer fixed point theorem) *For every continuous map*

$$f : D^n \rightarrow D^n$$

there is $x \in D^n$ such that $f(x) = x$.

Proof : The case $n = 0$ is trivial. For $n > 0$, assume that there is such an f without any fixed point. Define $F : D^n \rightarrow S^{n-1}$ by setting $F(x)$ equal to the unique point of intersection between $S^{n-1} = \partial D^n$ and the ray emanating from $f(x)$ and passing through x . As f is continuous, it is easy to verify that also F is continuous and that $\partial F = \text{id}_{S^{n-1}}$. Hence $[S^{n-1}]$ should be trivial in $\mathcal{B}_{n-1}(S^{n-1})$ against Proposition 10.8. □

12.2. A separation theorem

It is evident that an equatorial $S^{n-1} \subset S^n$ divides this last into two connected components. If $n \geq 2$, every connected hypersurface in S^n shares the same behaviour.

PROPOSITION 12.2. (1) *Let $M \subset S^n$ be a compact boundaryless connected submanifold, $\dim(M) = n - 1$, $n \geq 2$. Then $S^n \setminus M$ has exactly two connected components W, W' and the closures are compact submanifolds with boundary such that $\partial \bar{W} = \partial \bar{W}' = M$.*

(2) *Let $M \subset \mathbb{R}^n$ be a compact boundaryless connected submanifold, $\dim(M) = n - 1$, $n \geq 2$. Then $\mathbb{R}^n \setminus M$ has two connected components, one say W has compact closure and $\partial \bar{W} = M$.*

Proof : The item (2) follows from (1) by considering $\mathbb{R}^n \subset \mathbb{R}^n \cup \infty = S^n$, such that ∞ does not belong to M . As for (1), we know by Section 10.5 that $[M] := [M, i_M] \in \mathcal{B}_{n-1}(S^n; \mathbb{Z}/2\mathbb{Z}) \sim \mathcal{B}^1(S^n; \mathbb{Z}/2\mathbb{Z})$ (i_M being the inclusion) belongs to the submodule isomorphic to \mathcal{B}_{n-1} . Hence we know that $[M]$ belongs to the kernel of the map $\phi : \mathcal{B}^1(S^n; \mathbb{Z}/2\mathbb{Z}) \rightarrow \text{Hom}(\mathcal{B}_1(S^n; \mathbb{Z}/2\mathbb{Z}), \mathbb{Z}/2\mathbb{Z})$. Assume that $S^n \setminus M$ is connected. Take a small simple arc γ intersecting transversely M at one point. The endpoints of γ belong to $S^n \setminus M$, hence γ can be completed to a smooth simple curve $\hat{\gamma}$ in S^n that intersects transversely M at one point. It follows that $\phi_{[M]}([\hat{\gamma}, i_{\hat{\gamma}}]) = 1$ and this is a contradiction. Hence $S^n \setminus M$ is not connected. A tubular neighbourhood U of M in S^n is diffeomorphic to $M \times (-1, 1)$, in fact $M \times [0, 1)$ can be identified with a collar of M in \bar{W} , where W is a component of $S^n \setminus M$. Since $U \setminus M$ has evidently two connected components, then $S^n \setminus M$ has at most two components and this achieve the proof. \square

12.3. Intersection numbers

Let X be a compact connected (possibly oriented) boundaryless smooth n -manifold. Let M and N be compact boundaryless (possibly oriented) submanifolds of X , $\dim M = p$, $\dim N = q$. Assume that $p + q = n$. Then

$$[M] \bullet [N] \in R$$

is the R -intersection number of the two submanifolds. Obviously it is invariant up to isotopy of M or N in X (isotopy is a particular instance of bordism). Hence if $[M] \bullet [N] \neq 0$, then there is no any isotopy that makes M and N apart. In particular, if $M = N$ (hence $n = 2m$), then $M \bullet M$ is called the *self-intersection number* of the submanifold M .

12.3.1. Lefschetz's number and fixed point theorem. Let X be as above a connected compact boundaryless n -manifold. Let $f : X \rightarrow X$ be a smooth map. Consider the submanifolds Δ_X and $G(f)$ of $X \times X$, $G(f)$ being the graph of f . If $n = \dim(X)$, then

$$L_2(f) := [\Delta_X] \sqcup [G(f)] \in \mathcal{B}^{2n}(X \times X; \mathbb{Z}/2\mathbb{Z}) = \mathbb{Z}/2\mathbb{Z}$$

is called *the Lefschetz number of f mod(2)*. This is invariant (in particular) if f is considered up to homotopy. As usual this allows us to define this number also when f is merely a continuous map. It is clear that if $\Delta_X \cap G(f) = \emptyset$ (that is if f has no fixed points), then $L_2(f) = 0$. Viceversa we have the following “fixed point theorem”:

If $L_2(f) \neq 0$, then f has a fixed point.

If M is oriented, we can define the Lefschetz number

$$L(f) \in \mathcal{B}^{2n}(X \times X; \mathbb{Z}) = \mathbb{Z}, \quad L(f) = L_2(f) \text{ mod}(2)$$

in the oriented setting, and repeat verbatim the above considerations.

12.4. Linking numbers

Let X be as in Section 12.3, $n \geq 3$. Let $(M, \partial M)$ be a $(n - k)$ -compact submanifold (possibly oriented) of X with non empty boundary, $n - k \geq 1$. M is called a *R-Seifert surface of $T = \partial M$ in X* . Let U be a “small” tubular neighbourhood of T in X , such that $\partial U \pitchfork M$. The closure $(Y, \partial Y)$ ($\partial Y = \partial U$) of $X \setminus U$ is a compact n -manifold with non empty boundary; the closure $(N, \partial N)$ of $M \setminus U$ is a proper $(n - k)$ -submanifold of $(Y, \partial Y)$. Then $[N, \partial N] \in \mathcal{B}^k(Y, \partial Y; R)$ (we omit to indicate the inclusion map). Let Z be a compact boundaryless (possibly oriented) proper k -submanifold of $(Y, \partial Y)$. Hence $[Z] \in \mathcal{B}^{n-k}(Y; R)$. Then

$$lk_M(T, Z) := [N, \partial N] \sqcup [Z] \in R$$

is called the R -linking number of Z with T with respect to the Seifert surface M . By the uniqueness of tubular neighbourhoods up to isotopy, it is well defined. Moreover, it is invariant up to isotopy Z in $\text{Int}(Y)$. In some case the linking number does not depend on the choice of the Seifert surface. For example we have

PROPOSITION 12.3. *In the above setting, assume that $X = S^n$. Then*

$$lk(T, Z) := lk_M(T, Z) \in R$$

is well defined, that is it does not depend on the choice of a Seifert surface of T in S^n .

Proof : Let $T = \partial M = \partial M'$. By (abstractly) gluing M and M' along T and taking the union of the inclusions, we get say $[W, f] \in \mathcal{B}^k(S^n; R)$. Let us consider $[Z] \in \mathcal{B}^{n-k}(S^n)$. We have already noticed that

$$[W, f] \sqcup [Z] = 0 \in R .$$

On the other hand, it follows from the very geometric definition of the cobordism cup product that

$$[W, f] \cup [Z] = lk_W(T, Z) - lk_{W'}(T, Z)$$

and the Proposition follows. □

REMARK 12.4. A classical example of linking number is the case $X = S^3$ and T, Z (possibly oriented) disjoint *knots* in S^3 (that is disjoint submanifolds diffeomorphic to S^1). It is a classical well-known fact (see [Rolf]) that a knot in S^3 admits a Seifert surface. Hence we eventually have

$$lk(T, Z) = lk(Z, T) \in R .$$

Another classical situation is when $X = S^n$, $T \sim S^p$, $Z \sim S^q$ and these last are *unknotted spheres* in S^n , that is they are the boundary of embedded $(p+1)$ or $(q+1)$ smooth disks respectively.

12.5. Degree

Let X and Y be compact connected boundaryless (possibly oriented) smooth n -manifolds, $g : X \rightarrow Y$ be a continuous map. Let us fix generators β_X of $\mathcal{B}^n(X; R) = R$ and β_Y of $\mathcal{B}^n(Y; R) = R$ as in Section 11.4. Consider

$$g^* : \mathcal{B}^n(Y; R) \rightarrow \mathcal{B}^n(X; R)$$

then define the R -degree of g by:

$$\deg_R(g) := g^*(\beta_Y) \in R .$$

Although we have already given an operative definition of g^* in full generality, it is convenient to spell it again in the present situation: fix $y_0 \in Y$; up to homotopy make g smooth and transverse to y_0 (equivalently move a little y_0 to make it a regular value of g); then $g^{-1}(y_0) = \{x_1, \dots, x_r\}$ is a finite set of points; in the oriented setting they are oriented, that is endowed with signs ϵ_j , $j = 1, \dots, r$; on $R = \mathbb{Z}/2\mathbb{Z}$ the degree is equal to $r \bmod(2)$; on \mathbb{Z} the degree is the sum of the signs ϵ_j .

Now we list a few properties of the degree.

- If g is not surjective, then $\deg_R g = 0$.
- If $g : X \rightarrow Y$ is a diffeomorphism, then $\deg_R(g) = \pm 1$.
- If $h \circ g$ and the the degrees of all involved maps make sense, then

$$\deg_R(h \circ g) = \deg_R(h) \deg_R(g)$$

that is the degree is multiplicative under composition. This follows immediately from functoriality.

- If g and h are homotopic, then

$$\deg_R(g) = \deg_R(h)$$

this follows from (5) of Proposition 11.6.

- To define the degree of a map $f : X \rightarrow Y$ it is not strictly necessary that X is connected. In fact we can define

$$\deg_R(f) = \sum_{X_c} \deg_R(f|_{X_c})$$

where X_c varies among the connected components of X . By extending the above homotopy invariance, we have: If $[X_0, f_0] = [X_1, f_1] \in \mathcal{B}_n(Y; R)$ then

$$\deg_R(f_0) = \deg_R(f_1) .$$

- For every oriented X as above, $n \geq 1$, for every $r \in \mathbb{Z}$ there is $g : X \rightarrow S^n$ such that $\deg_{\mathbb{Z}}(g) = r$.

First we prove it when $X = S^n$, by induction on $n \geq 1$. Consider S^1 as the unitary circle of \mathbb{C} . The restriction of $z \rightarrow \bar{z}$ to S^1 has \mathbb{Z} -degree equal to -1 . For every $r \geq 1$, the restriction of $z \rightarrow z^r$ has \mathbb{Z} -degree equal to r . As the degree is multiplicative under composition this achieves the result for $n = 1$. For a given $r \in \mathbb{Z}$, let $g : S^n \rightarrow S^n$ be of degree equal to r ; we have to construct $\hat{g} : S^{n+1} \rightarrow S^{n+1}$ having the same degree. Take \hat{g} which fixes the northern and southern poles and holds $\hat{g}(x) = tg(x/t)$ on $S^{n+1} \cap \{x_{n+2} = t\}$, for every $t \in (-1, 1)$. One checks that it has \mathbb{Z} -degree equal to r as well. To finish it is enough to construct $g : X \rightarrow S^n$ of \mathbb{Z} -degree equal to ± 1 . Fix a smooth D^n contained in a chart of X . By using a tubular neighbourhood U of ∂D^n in X , it is not hard to construct a smooth map $g : X \rightarrow S^n$ such that the restriction of g to D^n is a diffeomorphism onto $D^- = \{x \in S^n \mid x_{n+1} \leq 0\}$, and holds constantly the northern pole of S^n on the complement of $D^n \cup U$ in X . Such a g does the job.

REMARK 12.5. For arbitrary oriented X and Y as above, it is in general a hard question to determine the set of $r \in \mathbb{Z}$ which can be realized as the \mathbb{Z} -degree of some $g : X \rightarrow Y$.

- Again in the case $X = Y = S^n$, $n \geq 1$. If $\rho : S^n \rightarrow S^n$ is the restriction of a reflection of \mathbb{R}^{n+1} along a linear hyperplane, then $\deg_{\mathbb{Z}}(\rho) = -1$. Denote by $a_n : S^n \rightarrow S^n$, $a_n(x) = -x$ the *antipodal map*; a_n is the composition of the restriction of $n + 1$ reflections (e.g. the reflections along the hyperplanes $\{x_j = 0\}$, $j = 1, \dots, n + 1$). Then we have

$$\deg_{\mathbb{Z}}(a_n) = (-1)^{n+1} .$$

- In the setting of Remark 12.4, let $S^n = \mathbb{R}^n \cup \infty$, $\infty \in S^n \setminus (T \cup Z)$.

$$L : T \times Z \rightarrow S^{n-1}, L(t, z) = \frac{t - z}{\|t - z\|}$$

then one can prove that

$$\deg_{\mathbb{Z}}(L) = \pm lk(T, Z)$$

we left it as a (non trivial) exercise.

12.5.1. A proof of the fundamental theorem of algebra. The fundamental theorem of algebra states that every non constant complex polynomial $p(Z) \in \mathbb{C}[Z]$ has a complex root a , $p(a) = 0$. There are several proofs; here is a topological/differential one based on the degree.

Let $p(Z)$ of degree $m \geq 1$. It is not restrictive to assume that

$$p(Z) = Z^m + \sum_{j=1}^m a_j Z^{m-j}$$

is monic. Define the homotopy through polynomial maps:

$$p_t(z) = tp(z) + (1-t)z^m = z^m + t\left(\sum_{j=1}^m a_j z^{m-j}\right), \quad t \in [0, 1].$$

By the compactness of $[0, 1]$, the ratios $p_t(z)/z^m$ tend uniformly to 1 when $|z| \rightarrow +\infty$. Hence there is R high enough such that for every $t \in [0, 1]$, the roots of $p_t(Z)$ are in the open ball $B_R = \{|z| < R\}$, with boundary $S_R \sim S^1$. Hence

$$p_t/|p_t| : S_R \rightarrow S^1$$

is a well defined smooth map for every t , so that $p_1/|p_1|(z) = p(z)/|p(z)|$ and $p_0/|p_0|(z) = z^m/R^m$ are homotopic to each other. It is immediate that

$$\deg_{\mathbb{Z}}(p_0/|p_0|) = m$$

hence also $\deg_{\mathbb{Z}}(p/|p|) = m$. On the other hand, if $p(Z)$ has no roots, then $p/|p|$ can be extended to the whole closed ball \bar{B}_R , it would be homotopically trivial, hence $\deg_{\mathbb{Z}}(p/|p|) = 0$, a contradiction. □

12.6. The Euler class of a vector bundle

Let

$$\xi := \pi : E \rightarrow X$$

be a vector bundle of *rank* k (that is k is the dimension of the fibre) over a compact boundaryless smooth n -manifold X . X is considered as a submanifold of E via the canonical *zero section* $s_0 : X \rightarrow E$. Then

$$[X] \in \mathcal{B}^k(E; \mathbb{Z}/2\mathbb{Z})$$

and set

$$w^k(\xi) := s_0^*([X]) \in \mathcal{B}^k(X; \mathbb{Z}/2\mathbb{Z}).$$

This is called the *Euler class of the vector bundle* ξ . Let us spell how to get nice representatives of this last cobordism class.

LEMMA 12.6. (1) *The subset $\pitchfork \Gamma(\xi, X)$ made by the sections $s : X \rightarrow E$ of ξ such that $s \pitchfork X$ is open and dense in $\Gamma(\xi)$.*

(2) *Two sections transverse to X are homotopic to each other through sections of ξ .*

Proof : As X is compact, the openness is now a routine fact. Let us show the density. Let $s : X \rightarrow E$ be any section. By transversality theorems, there is a map $z : X \rightarrow E$ close to s , $z \pitchfork X$, z not necessarily a section. If z is close enough to s , then $h = \pi \circ z$ is a diffeomorphism onto $X \subset E$. Then $z \circ h^{-1} : X \rightarrow E$ is a section close to s and transverse to X . Every section is homotopic to s_0 via a natural fibrewise radial homotopy. □

Let $s : X \rightarrow E$ be any section of ξ transverse to X . Then its zero set

$$Z_s = \{x \in X \mid s(x) = 0\}$$

is a proper submanifold of X of dimension $n - k$. It follows from the very definition of s_0^* that

LEMMA 12.7. *For any section $s : X \rightarrow E$, $s \pitchfork X$, we have*

$$w^k(\xi) = [Z_s] \in \mathcal{B}^k(X; \mathbb{Z}/2\mathbb{Z}) .$$

□

PROPOSITION 12.8. *For every couple ξ, ρ of vector bundles on X of rank r and s respectively, then*

$$w^{r+s}(\xi \oplus \rho) = w^r(\xi) \sqcup w^s(\rho) .$$

Proof : By using sections s and s' of ξ and ρ transverse to X in $E(\xi)$ and $E(\rho)$ respectively and such that $s \oplus s'$ is transverse to X in $E(\xi \oplus \rho)$, then

$$Z_{s \oplus s'} = Z_s \pitchfork Z_{s'}$$

we conclude by means of Lemma 12.7. □

It is evident that if there exists s such that $Z_s = \emptyset$, then $w^k(\xi) = 0$. Then:

The non vanishing of the Euler class $w^k(\xi)$ is a basic obstruction to the existence of a nowhere vanishing section of the vector bundle ξ .

If $k > n = \dim X$, then for every s as above $Z_s = \emptyset$ and this fits with $\mathcal{B}^k(X; \mathbb{Z}/2\mathbb{Z}) = 0$. It follows that ξ of rank $k > n$ is strictly isomorphic to $\eta \oplus \epsilon^{n-k}$, η being of rank n ; in other words

Every vector bundle over X is stably equivalent to a vector bundle of rank $\leq \dim(X)$.

PROPOSITION 12.9. *Let $g : X \rightarrow Y$ be a smooth map between compact boundaryless smooth manifolds. Let ξ be a rank k vector bundle over Y . Then*

$$w^k(g^*(\xi)) = g^*(w^k(\xi)) \in \mathcal{B}^k(X; \mathbb{Z}/2\mathbb{Z}) .$$

Proof : We stress that the first g^* refers to the vector bundle pull-back while the second refers to the cobordism pull-back. The two pull-back procedures are formally very similar and the equality is a direct consequence. □

Manifolds with boundary. If the compact manifold $(X, \partial X)$ has non empty boundary then, for every rank k vector bundle ξ on X , the same procedure defines the relative Euler class

$$w^k(\xi) \in \mathcal{B}^k(X, \partial X; \mathbb{Z}/2\mathbb{Z}) ,$$

if $i : \partial X \rightarrow X$ is the inclusion then (as a particular case of the above proposition)

$$i^*(w^k(\xi)) = w^k(i^*(\xi)) \in \mathcal{B}^k(\partial X; \mathbb{Z}/2\mathbb{Z}) .$$

Universal basic cobordism classes. If $g : X \rightarrow \mathfrak{G}_{h,k}$ is any classifying map of ξ so that ξ is strictly equivalent to $g^*(\tau_{h,k})$ then $w^k(\xi) = g^*(w^k(\tau_{h,k}))$, $w^k(\tau_{h,k}) \in \mathcal{B}^k(\mathfrak{G}_{h,k}; \mathbb{Z}/2\mathbb{Z})$. So these last can be considered as the *universal Euler classes of vector bundles*.

The total cobordism characteristic classes of projective spaces. Consider the particular case of the *real projective space* $\mathbf{P}^n(\mathbb{R}) = \mathfrak{G}_{n+1,1}$ with the tautological line bundle $\tau_{n+1,1}$. Then

$$\gamma^1 := w^1(\tau_{n+1,1}) = [Z^1] \in \mathcal{B}^1(\mathbf{P}^n; \mathbb{Z}/2\mathbb{Z})$$

where $Z^1 \sim \mathbf{P}^{n-1}(\mathbb{R})$ is any projective hyperplane in $\mathbf{P}^n(\mathbb{R})$. For every $s \geq 1$,

$$\gamma^s := \sqcup_{j=1}^s \gamma^1 = [Z^s]$$

where $Z^s \sim \mathbf{P}^{n-s}(\mathbb{R})$ is any codimension s projective subspace of $\mathbf{P}^n(\mathbb{R})$. Set $\gamma^0 := [Z^0] = [\mathbf{P}^n(\mathbb{R})]$ the $\mathbb{Z}/2\mathbb{Z}$ -fundamental class. Clearly if $s \leq n$,

$$\gamma^s \sqcup \gamma^{n-s} = 1$$

hence they do not belong to $\ker(\phi^s)$ and $\ker(\phi^{n-s})$ respectively. If $s > n$, $\gamma^s = 0$. By definition

$$\sum_{s=0}^n \gamma^s \in \mathcal{B}^\bullet(\mathbf{P}^n(\mathbb{R}); \mathbb{Z}/2\mathbb{Z})$$

is the *total $\mathbb{Z}/2\mathbb{Z}$ -cobordism characteristic class of $\mathbf{P}^n(\mathbb{R})$* . If necessary we write $\gamma^s = \gamma_n^s$ in order to stress that it refers to $\mathbf{P}^n(\mathbb{R})$. Then if we consider any linear inclusion $j : \mathbf{P}^k(\mathbb{R}) \rightarrow \mathbf{P}^n(\mathbb{R})$, $k \leq n$, $\mathbf{P}^k(\mathbb{R}) = Z^{n-k}$ as above, then for every $m \geq 0$,

$$\gamma_k^m = j^*(\gamma_n^m) .$$

12.6.1. Oriented vector bundles. A rank r vector bundle ξ over X is oriented if it is defined by a maximal fibred atlas with $\mathrm{GL}^+(k, \mathbb{R})$ cocycle. If the base manifold is also oriented, then the total space manifold is naturally oriented itself. If X is compact boundaryless, then we can repeat the above constructions in the oriented setting. This define the *oriented Euler class*

$$e^r(\xi) := j^*([X]) \in \mathcal{B}^r(X; \mathbb{Z}) .$$

$\omega^r(\xi)$ is the image of $e^r(\xi)$ via the natural forgetting map $\mathcal{B}(X; \mathbb{Z}) \rightarrow \mathcal{B}(X; \mathbb{Z}/2\mathbb{Z})$. For every pair of oriented bundles over X of rank r and s respectively

$$e^{r+s}(\xi \oplus \rho) = e^r(\xi) \sqcup e^s(\rho) \in \mathcal{B}^{r+s}(X; \mathbb{Z}) ;$$

for every $f : X \rightarrow Y$ smooth maps between oriented compact boundaryless manifolds, for every oriented rank r vector bundle ξ bundle over Y ,

$$g^*(e^r(\xi)) = e^r(g^*(\xi)) \in \mathcal{B}^r(X; \mathbb{Z}) .$$

Similarly we have relative oriented Euler classes $e^k(\xi) \in \mathcal{B}^k(X, \partial X; \mathbb{Z})$ when X has non empty boundary

□

A case of main interest is the tangent bundle of X ; then

$$w^n(X) := w^n(T(X)) \in \mathcal{B}^n(X; \mathbb{Z}/2\mathbb{Z}) = \mathbb{Z}/2\mathbb{Z}$$

provides a basic obstruction to the existence of nowhere vanishing tangent vector fields on X .

If we consider the rank 1 determinant bundle of X , then

$$w^1(X) := w^1(\det T(X)) \in \mathcal{B}^1(X; \mathbb{Z}/2\mathbb{Z})$$

provides a basic obstruction in order that X is orientable. We will see in Corollary 13.4 that it is a *complete* obstruction.

We will develop the case of (real and complex) rank 1 bundles (also called *line bundles*) in Chapter 13. We will develop the study of the Euler class of the tangent bundle of X in Chapter 14.

12.7. Borsuk-Ulam theorem

By definition a map $f : S^n \rightarrow S^m$ is *antipodal preserving* if for every $x \in S^n$,

$$f(-x) = -f(x) .$$

PROPOSITION 12.10. *For every $n \geq 1$, there does not exist any continuous antipodal preserving map $f : S^n \rightarrow S^{n-1}$.*

The following corollary is known as the *Borsuk-Ulam theorem*.

COROLLARY 12.11. *For every $n \geq 1$, for every continuous map $f : S^n \rightarrow \mathbb{R}^n$, there exists $x \in S^n$ such that $f(x) = f(-x)$.*

For example, assuming that the surface of the earth is a round sphere and that temperature and pressure vary continuously on it in space and time, then at every instant there is a couple of antipodal points at which we have the same couple of temperature and pressure values.

Proof of BUT. By contradiction, if a given f does not verifies the conclusion of the Corollary, then

$$g : S^n \rightarrow \mathbb{R}^n, \quad g(x) = f(x) - f(-x)$$

is continuous, nowhere vanishing, and for every $x \in S^n$,

$$g(-x) = f(-x) - f(x) = -g(x).$$

Then

$$\hat{g} : S^n \rightarrow S^{n-1}, \quad \hat{g}(x) = g(x)/\|g(x)\|$$

is continuous and would be antipodal preserving, against Proposition 12.10

□

Proof of Proposition 12.10. To lighten the notations, in this proof we will use $\eta_k(*)$ instead $\mathcal{B}_k(*; \mathbb{Z}/2\mathbb{Z})$, and write \mathbf{P}^m instead of $\mathbf{P}^m(\mathbb{R})$.

The case $n = 1$ is evident because S^1 is connected while $S^0 = \{\pm 1\}$ is not.

For $n = 2$ we use some basic facts about the fundamental group of a manifold and its action on a universal covering space. Assume that there is such a continuous antipodal preserving map $f : S^2 \rightarrow S^1$. It induces a map $\hat{f} : \mathbf{P}^2 \rightarrow \mathbf{P}^1 \sim S^1$ such that the following diagram commutes, the vertical maps being the natural degree 2 covering maps:

$$\begin{array}{ccc} S^2 & \xrightarrow{f} & S^1 \\ \downarrow p_2 & & \downarrow p_1 \\ \mathbf{P}^2 & \xrightarrow{\hat{f}} & \mathbf{P}^1 \end{array} .$$

We know that $\pi_1(\mathbf{P}^2, x_0) \sim \mathbb{Z}/2\mathbb{Z}$, generated by the class of a projective line passing through the base point, while $\pi_1(\mathbf{P}^1, \hat{f}(x_0)) \sim \mathbb{Z}$, generated by the the identity loop. Hence the induced homomorphism $\hat{f}_* : \pi_1(\mathbf{P}^2, x_0) \rightarrow \pi_1(\mathbf{P}^1, \hat{f}(x_0))$ is necessarily trivial. On the other hand, take the two antipodal points $x, -x \in S^2$ over x_0 and an arc σ in S^2 that joins them. Then $p_2(\sigma)$ represents a non trivial element of $\pi_1(\mathbf{P}^2, x_0)$, because it acts non trivially on S^2 which is the universal covering of the projective plane. The class $\hat{f}_*(\langle p_2(\sigma) \rangle)$ is represented by $p_1 \circ f \circ \sigma$ and again it is non trivial because it acts non trivially on the universal covering space of \mathbf{P}^1 that dominates the covering p_1 . This is against the fact that $\hat{f}_* = 0$.

If $n > 2$ we have a similar commutative diagram

$$\begin{array}{ccc} S^n & \xrightarrow{f} & S^{n-1} \\ \downarrow p_n & & \downarrow p_{n-1} \\ \mathbf{P}^n & \xrightarrow{\hat{f}} & \mathbf{P}^{n-1} \end{array}$$

where both vertical maps are now universal covering maps. Both fundamental groups are isomorphic to $\mathbb{Z}/2\mathbb{Z}$ and the very same argument used above shows that

$$\hat{f}_* : \pi_1(\mathbf{P}^n, x_0) \rightarrow \pi_1(\mathbf{P}^{n-1}, \hat{f}(x_0))$$

is an isomorphism. Any surjective homomorphism $g : \mathbb{Z}/2\mathbb{Z} \rightarrow G$ either is an isomorphism or $G = 0$ and g is trivial. For every $m > 1$, the surjective homomorphism

$$\hat{h} := \sigma_1 \circ h_1 : \pi_1(\mathbf{P}^m, x_0) \rightarrow \eta_1(\mathbf{P}^m)$$

is non trivial (the class of a projective line Z^{m-1} passing through the base point is sent by \hat{h} to the non trivial class $[Z^{m-1}] \in \eta_1(\mathbf{P}^m)$, for via the tautological isomorphism $[Z^{m-1}] = \gamma_m^{m-1} \in \eta^{m-1}(\mathbf{P}^m)$, and we know that $\gamma_m^{m-1} \sqcup \gamma^1 = 1$). Hence \hat{h} is an isomorphism and \hat{f} induces an isomorphism (we keep the notation)

$$\hat{f}_* : \eta_1(\mathbf{P}^n) \rightarrow \eta_1(\mathbf{P}^{n-1}) .$$

For every $m > 1$, $\text{Hom}(\eta_1(\mathbf{P}^m), \mathbb{Z}/2\mathbb{Z}) \sim \mathbb{Z}/2\mathbb{Z}$. Then in our situation

$$f_*^t : \text{Hom}(\eta_1(\mathbf{P}^{n-1}), \mathbb{Z}/2\mathbb{Z}) \rightarrow \text{Hom}(\eta_1(\mathbf{P}^n), \mathbb{Z}/2\mathbb{Z})$$

is also an isomorphism. For every $m > 1$,

$$\hat{\phi} : \eta^1(\mathbf{P}^m) / \ker(\phi) \rightarrow \text{Hom}(\eta_1(\mathbf{P}^m), \mathbb{Z}/2\mathbb{Z})$$

is an isomorphism and $\eta^1(\mathbf{P}^m) / \ker(\phi)$ is generated by γ_m^1 . Then on one hand we would have

$$\hat{f}^*(\gamma_{m-1}^1) = \gamma_m^1, \quad \hat{f}_*(\hat{\phi}(\gamma_{m-1}^1)) = \hat{\phi}(\gamma_m^1)$$

on another hand

$$0 = \hat{f}^*(0) = \hat{f}^*(\sqcup_{s=1}^m \gamma_{m-1}^1) = \sqcup_{s=1}^m \gamma_m^1 = 1$$

and this is a contradiction. □

Line bundles, hypersurfaces and cobordism

In this chapter X will denote a compact boundaryless smooth manifold and we also assume that X is connected (in general we can apply the next arguments to every connected component). We will use indifferently the notations $\eta_j(X)$ or $\mathcal{B}_j(X; \mathbb{Z}/2\mathbb{Z})$ (resp. $\Omega_j(X)$ or $\mathcal{B}_j(X; \mathbb{Z})$) and so on. Recall also

$$\mathcal{H}^r(X; R) := \mathcal{B}^r(X; R) / \ker(\phi^r)$$

defined in Section 11.4. By means of the Euler classes of line bundles over X one can achieve a good understanding of $\eta^1(X) = \mathcal{B}^1(X; \mathbb{Z}/2\mathbb{Z})$. If X is oriented, we will get information about $\Omega^1(X)$ and by using *complex* line bundles also about $\Omega^2(X)$.

13.1. Real line bundles and hypersurfaces

Let X be as above. Denote by

$$\mathcal{V}_1(X)$$

the set of rank 1 real vector bundles on X (also called (real) *line bundles*) considered up to strict equivalence. We know from Chapter 4 that

$$\mathcal{V}_1(X) \sim [X, \mathbf{P}^\infty(\mathbb{R})]$$

where this last is the space of homotopy classes of *classifying maps* $f \in \mathcal{E}(X, \mathbf{P}^\infty(\mathbb{R}))$, and the bijective correspondence is given via the pull back of the tautological line bundle:

$$[X, \mathbf{P}^\infty(\mathbb{R})] \rightarrow \mathcal{V}_1(X), [f] \rightarrow [f^*(\tau_{\infty,1})].$$

Moreover, by Section 5.13.1 we know that we can “truncate” the classifying maps so that eventually

$$\mathcal{V}_1(X) \sim [X, \mathbf{P}^{m(n)}(\mathbb{R})]$$

where $m = m(n)$ is big enough only depending on n . Often we will confuse a class with a given representative (say we write f instead of $[f]$, ξ instead of $[\xi]$, and so on). Recall that the *tensor product* defines an operation

$$\otimes : \mathcal{V}_1(X) \times \mathcal{V}_1(X) \rightarrow \mathcal{V}_1(X), (\xi, \beta) \rightarrow \xi \otimes \beta.$$

In Section 12.6, we have defined a map

$$w^1 : \mathcal{V}_1(X) \rightarrow \eta^1(X), \xi \rightarrow w^1(\xi)$$

which associates to every line bundle its Euler class. Precisely $w^1(\xi)$ can be represented as

$$w^1(\xi) = [Z]$$

where Z is a smooth compact *hypersurface* in X given as the zero set $Z = Z_s$ of any section $s \in \Gamma(\xi)$ transverse to X in $E(\xi)$, where X is canonically embedded in the total space of ξ by the zero section s_0 . Moreover, if Z_0 and Z_1 are two such zero sets, then we can realize the equality of their bordism classes $[Z_0] = [Z_1] \in \eta^1(X)$ by means of *embedded bordisms*:

There exists a proper hypersurface $(Y, \partial Y)$ of $(X \times [0, 1], (X \times \{0\}) \amalg (X \times \{1\}))$ such that $\partial Y = Z_0 \amalg Z_1$, $Z_i \subset X \times \{i\}$. The map which interpolates the two inclusions $j_i : Z_i \rightarrow X$ is the projection onto X .

So we denote by

$$\eta_{\text{Emb}}^1(X)$$

the set of proper smooth hypersurfaces of X considered up to embedded bordism. There is a natural projection

$$\mathfrak{p} : \eta_{\text{Emb}}^1(X) \rightarrow \eta^1(X)$$

so that the above map w^1 factorizes as

$$w^1 = \mathfrak{p} \circ \hat{w}^1$$

through a well defined map

$$\hat{w}^1 : \mathcal{V}_1(X) \rightarrow \eta_{\text{Emb}}^1(X) .$$

We have

PROPOSITION 13.1. (1) The map $\hat{w}^1 : \mathcal{V}_1(X) \rightarrow \eta_{\text{Emb}}^1(X)$ is bijective.

(2) For every couple $(\xi, \beta) \in \mathcal{V}_1^2$,

$$w^1(\xi \otimes \beta) = w^1(\xi) + w^1(\beta) .$$

(3) The projection \mathfrak{p} maps $\eta_{\text{Emb}}^1(X)$ onto a $\mathbb{Z}/2\mathbb{Z}$ -submodule, say $\mathbf{H}^1(X; R)$, of $\mathcal{B}^1(X; \mathbb{Z}/2\mathbb{Z})$, the one made by the (unoriented) cobordism classes that can be represented by embedded hypersurfaces).

Proof : Let us describe the inverse map of \hat{w}^1 . For every proper hypersurface Z of X we have to construct a line bundle ξ_Z on X such that $Z = Z_s$ for some $s \in \Gamma(\xi_Z)$, $s \pitchfork X$. We can find a finite nice atlas of (X, Z) , $\{(W_j, \phi_j)\}$ such that for every j , there is a summersion $f_j : W_j \rightarrow \mathbb{R}$, such that $W_j \cap Z = \{f_j = 0\}$. On $W_i \cap W_j$, by Remark 1.10 (2) the ratio f_i/f_j defined a priori outside the zero set of f_j , extends to a well defined, smooth and nowhere vanishing function

$$g_{i,j} : W_i \cap W_j \rightarrow \mathbb{R}, \quad g_{i,j}(x) = f_i(x)/f_j(x) .$$

Hence

$$\{g_{i,j} : W_i \cap W_j \rightarrow \mathbb{R}^*\}$$

actually defines a cocycle of a line bundle ξ_Z on X which has the desired properties by construction.

As for (2), we can assume that ξ and β are defined by means of cocycles $\{\mu_{i,j}\}$ and $\{\nu_{i,j}\}$ respectively over a same nice atlas of X . Then $\{\mu_{i,j}\nu_{i,j}\}$ is a cocycle for $\xi \otimes \beta$. Then if $\{s_i\}$ and $\{s'_i\}$ are representations in local coordinates of sections s and s' of ξ and β respectively, such that $s \pitchfork X$, $s' \pitchfork X$, $s \pitchfork s'$, then $\{s_i s'_i\}$ determines a section say ss' of $\xi \otimes \beta$ such that $[Z_s] = w^1(\xi)$, $[Z_{s'}] = w^1(\beta)$; by perturbing ss' to get $s'' \pitchfork X$, eventually $Z_{s''}$ represents $w^1(\xi \otimes \beta)$ and $[Z_{s''}] = [(Z_s, i) \amalg (Z_{s'}, i')]$. In fact $Z_{s''}$ can be considered as an embedded desingularization in X of $Z_s \cup Z_{s'}$, which is singular along the codimension 2 submanifold $Y = Z_s \pitchfork Z_{s'}$.

Item (3) is a consequence of (1) and (2). □

13.2. Real line bundles and $\text{Rep}(\pi_1, \mathbb{Z}/2\mathbb{Z})$

Recall that we are assuming that X is connected. We denote by $\text{Rep}(\pi_1(X), \mathbb{Z}/2\mathbb{Z})$ the set of group homomorphisms (the base point of X is understood). Recall the linear map

$$\phi : \eta^1(X) \rightarrow \text{Hom}(\eta_1, \mathbb{Z}/2\mathbb{Z}), \quad \phi_\gamma(\sigma) = \gamma \sqcap \sigma .$$

Recall the surjective homomorphism

$$\hat{h} : \pi_1(X) \rightarrow \eta_1(X) .$$

Then we define the map

$$\kappa : \mathcal{V}_1(X) \rightarrow \text{Rep}(\pi_1(X), \mathbb{Z}/2\mathbb{Z}), \quad \kappa(\xi) = \phi_{w^1(\xi)} \circ \hat{h} .$$

Here is a concrete way to describe $\kappa(\xi)$. As $\pi_1(\mathbf{P}^\infty(\mathbb{R})) = \mathbb{Z}/2\mathbb{Z}$, then $\mathcal{V}_1(S^1)$ consists of two line bundles: the trivial and the non trivial one which has the total space diffeomorphic to an open Möbius band. If $\sigma = \langle f : S^1 \rightarrow X \rangle \in \pi_1(X)$, then $\kappa(\xi)(\sigma) = 1$ if and only if $f^*\xi$ is non trivial. We have

PROPOSITION 13.2. *The map $\kappa : \mathcal{V}_1(X) \rightarrow \text{Hom}(\pi_1(X), \mathbb{Z}/2\mathbb{Z})$ is bijective.*

Proof : We have already remarked in Example 4.11 that $\mathbf{P}^\infty(\mathbb{R})$ is a $K(\mathbb{Z}/2\mathbb{Z}, 1)$ space. It is a fundamental property of such a space that for every

$$\sigma \in \text{Rep}(\pi_1(X), \mathbb{Z}/2\mathbb{Z})$$

there is a unique

$$f \in [X, \mathbf{P}^\infty(\mathbb{R})]$$

such that

$$\sigma = f_* : \pi_1(X) \rightarrow \pi_1(\mathbf{P}^\infty(\mathbb{R})) .$$

Then

$$\sigma \rightarrow \xi_\sigma := f^*(\tau_{\infty,1})$$

defines the inverse map of κ . Equivalently, we can describe κ^{-1} in terms of degree 2 covering maps. It is known that there is a bijection between the degree 2 covering maps over X (up to strict equivalence) and $\text{Rep}(\pi_1(X), \mathbb{Z}/2\mathbb{Z})$. For every line bundle ξ , $\kappa(\xi)$ corresponds to the double covering of X given by the unitary bundle with fibre S^0 associated to ξ . Viceversa every degree 2 covering of X can be considered as a fibre bundle defined by a cocycle over a finite open covering of X with values in the multiplicative subgroup $\{\pm 1\}$ of \mathbb{R}^* . So it can be considered as the unitary bundle associated to the line bundle determined by the same cocycle. □

Referring to Proposition 13.1, we have the following immediate corollaries.

COROLLARY 13.3. (1) *The map $\mathfrak{p} : \eta_{\text{Emb}}^1(X) \rightarrow \mathbf{H}^1(X; \mathbb{Z}/2\mathbb{Z}) \subset \mathcal{B}^1(X; \mathbb{Z}/2\mathbb{Z})$ is bijective.*

$$(2) \mathbf{H}^1(X; \mathbb{Z}/2\mathbb{Z}) \sim \mathcal{H}^1(X; \mathbb{Z}/2\mathbb{Z}) \sim \text{Hom}(\eta_1(X), \mathbb{Z}/2\mathbb{Z}).$$

$$(3) \mathcal{V}_1(X) \sim \mathcal{H}^1(X; \mathbb{Z}/2\mathbb{Z}).$$

□

Another consequence of the above discussion is that

$\mathcal{H}^1(X; \mathbb{Z}/2\mathbb{Z})$ is finite dimensional.

For as X is compact, then $\pi_1(X)$ is finitely generated, hence $\eta_1(X) = \hat{h}(\pi_1(X))$ is a finite dimensional $\mathbb{Z}/2\mathbb{Z}$ -vector space as well as $\mathcal{H}^1(X; \mathbb{Z}/2\mathbb{Z})$.

By applying the above results to the determinant line bundle of X we have

COROLLARY 13.4. *A compact connected boundaryless smooth manifold X is orientable if and only if $w^1(X) = 0 \in \mathcal{H}^1(X; \mathbb{Z}/2\mathbb{Z})$.* □

13.3. Oriented hypersurfaces and Ω^1

Assume that X is oriented. Then we have the \mathbb{Z} -linear map

$$\phi : \Omega^1(X) \rightarrow \text{Hom}(\Omega_1(X), \mathbb{Z})$$

and via the homomorphism

$$h : \pi_1(X) \rightarrow \Omega_1(X)$$

we define a map

$$\kappa : \Omega^1(X)/\ker(\phi) \rightarrow \text{Rep}(\pi_1(X); \mathbb{Z}) .$$

As usual

$$[X, S^1]$$

is the set of homotopy classes in $\mathcal{E}(X, S^1)$. Denote by β_{S^1} the usual generator of $\Omega^1(S^1)$ which fixes the identification $\Omega^1(S^1) = \mathbb{Z}$. We have the \mathbb{Z} -linear map

$$\mathfrak{w} : [X, S^1] \rightarrow \Omega^1(X), f \rightarrow f^*(\beta_{S^1}) .$$

In fact

$$f^*(\beta_{S^1}) = [Z]$$

where Z is an oriented proper hypersurface of X of the form

$$Z = f^{-1}(s_0)$$

s_0 being any regular value of f . We denote by

$$\Omega_{\text{Emb}}^1(X)$$

the set of of proper oriented hypersurfaces of X considered up to *oriented embedded bordism* (this notion is the natural enhancement of the unoriented one given above).

Then we have the projection

$$\mathfrak{p} : \Omega_{\text{Emb}}^1(X) \rightarrow \Omega^1(X)$$

such that \mathfrak{w} factorizes as $\hat{\mathfrak{w}} \circ \mathfrak{p}$ for a well defined map

$$\hat{\mathfrak{w}} : [X, S^1] \rightarrow \Omega_{\text{Emb}}^1(X) .$$

Finally we have the map

$$\mathfrak{r} : [X, S^1] \rightarrow \text{Rep}(\pi_1(X); \mathbb{Z}), f \rightarrow f_* : \pi_1(X) \rightarrow \pi_1(S^1) = \mathbb{Z} .$$

We have

PROPOSITION 13.5. (1) *The map $\hat{\mathfrak{w}} : [X, S^1] \rightarrow \Omega_{\text{Emb}}^1(X)$ is bijective.*

(2) *The map $\mathfrak{r} : [X, S^1] \rightarrow \text{Rep}(\pi_1(X); \mathbb{Z})$ is bijective.*

(3) *The map $\kappa : \mathcal{H}^1(X; \mathbb{Z}) \rightarrow \text{Rep}(\pi_1(X); \mathbb{Z})$ is bijective.*

(4) *The projection $\mathfrak{p} : \Omega_{\text{Emb}}^1(X) \rightarrow \Omega^1(X)$ is injective onto a \mathbb{Z} -submodule say*

$$\mathbf{H}^1(X; \mathbb{Z}) \subset \mathcal{B}^1(X; \mathbb{Z}) .$$

(5) $\mathbf{H}^1(X; \mathbb{Z}) \sim \mathcal{H}^1(X; \mathbb{Z}) \sim \text{Hom}(\Omega_1, \mathbb{Z})$.

(6) $\mathcal{H}^1(X; \mathbb{Z})$ is finitely generated.

Proof : Let us define the inverse map of $\hat{\mathfrak{w}}$. This is a first sample of a general construction that we will study with all details in Chapter 17. So we limit here to indicate the main points. Let Z be a proper oriented hypersurface of X . As both X and Z are oriented, we can fix a global trivialization $t : Z \times (-1, 1) \rightarrow U$ of a tubular neighbourhood of Z in X . Let s_- the southern pole of S^1 , $s_+ := \infty$ the northern one. Let $D \sim (-1, 1)$ be an open interval in S^1 centred at s_- . Then the composition of t^{-1} with the projection onto $(-1, 1)$ define a local summersion $f : U \rightarrow D \subset S^1$. By using a suitable partition of unity as usual, we can globally define $f_Z : X \rightarrow S^1$ such that f_Z is constantly equal to ∞ on the complement of U , equals f on $t((-1/2, 1/2))$ and $f^{-1}(s_-) = Z$. One verifies that the homotopy class of such a map f_Z is invariant up to oriented embedded bordism of hypersurfaces, so $[Z] \rightarrow [f_Z]$ eventually defines the inverse map of $\hat{\mathfrak{w}}$. This achieves (1).

As for (2), it is well known that S^1 is a $K(\mathbb{Z}, 1)$ space. Hence for every $\sigma \in \text{Rep}(\pi_1(X); \mathbb{Z})$, there is $f^\sigma : X \rightarrow S^1$, uniquely defined up to homotopy, such that $\sigma = f_*^\sigma : \pi_1(X) \rightarrow \pi_1(S^1) = \mathbb{Z}$. This defines the inverse map of κ .

The item (3) follows from (1) and (2) by readily noticing that if $[Z] = \hat{\mathfrak{w}}([f])$, then $f_* = \phi([Z])$. Items (4) and (5) are basically a rephrasing of the previous ones; (6) follows again from the fact that X is compact, hence $\pi_1(X)$ is finitely generated and the homomorphism h is surjective. □

13.4. Complex line bundles and Ω^2

Assume again that X is oriented. Denote by

$$\mathcal{V}_1(X, \mathbb{C})$$

the set of *complex* line bundles over X considered up to strict equivalence. Similarly to the real case,

$$\mathcal{V}_1(X, \mathbb{C}) \sim [X, \mathbf{P}^\infty(\mathbb{C})]$$

where this last is the space of homotopy classes of *classifying maps* $f \in \mathcal{E}(X, \mathbf{P}^\infty(\mathbb{C}))$, and the bijective correspondence is given via the pull back of the tautological complex line bundle:

$$[X, \mathbf{P}^\infty(\mathbb{C})] \rightarrow \mathcal{V}_1(X, \mathbb{C}), [f] \rightarrow [f^*(\tau_{\infty,1}^{\mathbb{C}})] .$$

Moreover, we can “truncate” the classifying maps so that eventually

$$\mathcal{V}_1(X, \mathbb{C}) \sim [X, \mathbf{P}^{m(n)}(\mathbb{C})]$$

where $m = m(n)$ is big enough only depending on $n = \dim(X)$. Every complex line bundle ξ underlies a rank 2 *oriented* real bundle $\xi_{\mathbb{R}}$. Viceversa, every rank 2 oriented real bundle can be endowed with a structure a complex line bundle by reducing the structural group to $SO(1)$ and by identifying the rotation by $\pi/2$ to the product by $\sqrt{-1}$. Then we can define

$$e^2 : \mathcal{V}_1(X; \mathbb{C}) \rightarrow \Omega^2(X), \xi \rightarrow e^2(\xi_{\mathbb{R}})$$

which associates to every ξ the oriented Euler class of its “realification”. Precisely $e^2(\xi)$ can be represented as

$$e^2(\xi) = [Z]$$

where Z is a proper codimension 2 oriented smooth submanifold of X given as the oriented zero set $Z = Z_s$ of any section $s \in \Gamma(\xi_{\mathbb{R}})$ transverse to X in $E(\xi_{\mathbb{R}})$. If Z_0 and Z_1 are two such zero sets, then we can realize the equality of their bordism classes $[Z_0] = [Z_1] \in \Omega^2(X)$ by means of *oriented embedded bordisms* via proper oriented codimension 2 submanifold $(Y, \partial Y)$ of $(X \times [0, 1], (X \times \{0\}) \amalg (X \times \{1\}))$. Similarly as above denote by $\Omega_{\text{Emb}}^2(X)$ the set of codimension 2 oriented proper submanifolds of X considered up to embedded oriented bordism, and

$$\mathfrak{p} : \Omega_{\text{Emb}}^2(X) \rightarrow \Omega^2(X)$$

the natural projection. The map e^2 factorizes as $\mathfrak{p} \circ \hat{e}^2$ where

$$\hat{e}^2 : \mathcal{V}_1(\mathbb{C}) \rightarrow \Omega_{\text{Emb}}^2(X) .$$

Recall the \mathbb{Z} -linear map

$$\phi^2 : \Omega^2 \rightarrow \text{Hom}(\Omega_2(X), \mathbb{Z})$$

which composed with e^2 and the homomorphism

$$h : \pi_2(X) \rightarrow \Omega_2(X)$$

leads to the map

$$\kappa : \mathcal{V}_1(\mathbb{C}) \rightarrow \text{Rep}(\pi_2(X), \mathbb{Z}) .$$

Finally, analogously to the real case, $\mathbf{P}^\infty(\mathbb{C})$ is a $K(\mathbb{Z}, 2)$ -space ([**Hatch**]), hence it is defined and is *bijective* the map

$$\mathfrak{r} : [X, \mathbf{P}^\infty(\mathbb{C})] \rightarrow \text{Rep}(\pi_2(X), \mathbb{Z}), f \rightarrow f_* : \pi_2(X) \rightarrow \pi_2(\mathbf{P}^\infty(\mathbb{C})) = \mathbb{Z} .$$

By combining these facts similarly to the real case we have

- PROPOSITION 13.6. (1) The map $e^2 : \mathcal{V}_1(\mathbb{C}) \rightarrow \Omega_{\text{Emb}}^2(X)$ is bijective.
(2) For every $(\xi, \beta) \in \mathcal{V}_1^2(\mathbb{C})$, $e^2(\xi \otimes_{\mathbb{C}} \beta) = e^2(\xi) + e^2(\beta)$.
(3) The map $\kappa : \mathcal{V}_1(\mathbb{C}) \rightarrow \text{Rep}(\pi_2(X), \mathbb{Z})$ is bijective.
(4) The projection \mathfrak{p} is injective and maps $\Omega_{\text{Emb}}^2(X)$ onto a \mathbb{Z} -submodule, say $\mathbf{H}^2(X; \mathbb{Z})$ of $\mathcal{B}^2(X; \mathbb{Z})$.
(5) $\mathbf{H}^2(X; \mathbb{Z}) \sim \mathcal{H}^2(X; \mathbb{Z}) \sim \text{Hom}(\Omega_2(X)/\phi^2, \mathbb{Z})$.

□

13.4.1. Relative case. If $(X, \partial X)$ is compact with non empty boundary, possibly oriented, this is part of the setting of Section 11.5. So one can elaborate a relative version of the previous results. We limit to state the existence of isomorphisms

$$\mathcal{H}^1(X, \partial X; \mathbb{Z}/2\mathbb{Z}) \rightarrow \text{Hom}(\mathcal{H}_1(X; \mathbb{Z}/2\mathbb{Z}), \mathbb{Z}/2\mathbb{Z})$$

$$\mathcal{H}^1(X, \partial X; \mathbb{Z}) \rightarrow \text{Hom}(\mathcal{H}_1(X; \mathbb{Z}), \mathbb{Z})$$

$$\mathcal{H}^2(X, \partial X; \mathbb{Z}) \rightarrow \text{Hom}(\mathcal{H}_2(X; \mathbb{Z}), \mathbb{Z}) .$$

13.5. Seifert's surfaces

Let X be a compact oriented boundaryless manifold. By applying similar arguments about complex line bundles or rank 2 oriented real bundles, we want to prove the following proposition.

PROPOSITION 13.7. *Let $Y \subset X$ be a proper oriented codimension 2 submanifold of X . Assume that $[Y] \in \ker(\phi)$, that is $[Y] = 0 \in \mathcal{H}^2(X; \mathbb{Z})$. Let $\pi : U \rightarrow Y$ be a tubular neighbourhood of Y in X . Let $W = X \setminus \text{Int}(U)$ with boundary $\partial W = \partial U$. Then there exists a compact oriented hypersurface with boundary \tilde{Z} of X such that $\partial \tilde{Z} = Y$. Such a \tilde{Z} is called a Seifert surface of Y . Precisely, \tilde{Z} is transverse to ∂W , $(Z, \partial Z) := (\tilde{Z} \cap W, \tilde{Z} \cap \partial W)$ is a proper oriented hypersurface in $(W, \partial W)$, $U \cap \tilde{Z}$ is a collar of Y in \tilde{Z} .*

Proof : Let $i : Y \rightarrow X$ be the inclusion. Any tubular neighbourhood $p : U \rightarrow Y$ of Y in X can be associated to a direct sum decomposition of the form

$$i^*(T(X)) = T(Y) \oplus \xi_{\mathbb{R}}$$

where $\xi_{\mathbb{R}}$ is the “realification” of a complex line bundle on Y . As $[Y] \in \ker(\phi)$, then $e^2(\xi) = 0$, hence ξ is trivial so that U admits global trivialisations which induce trivialisations of ∂W . Let us fix one $h_0 : \partial W \rightarrow Y \times S^1$. Fix one oriented fibre $D \sim D^2$ of π with oriented boundary $S \sim S^1$. We claim that $[S]$ is of infinite order in $\Omega_1(W)$. By contradiction, let us assume that say $p \neq 0$ parallel copies of S are the boundary of a singular manifold $g : (V, \partial V) \rightarrow (W, \partial W)$. Then by gluing V and p parallel copies of D along the boundary, we would get an “absolute” singular 2-manifold (\tilde{V}, \tilde{g}) in X such that $[Y] \sqcup [\tilde{V}, \tilde{g}] = p$, against the fact that $[Y] \in \ker(\phi)$. As $[S]$ is indivisible in $\Omega_1(W)$, there exists $\psi \in \text{Hom}(\Omega_1(W), \mathbb{Z})$ such that $\psi([S]) = 1$. We know that ψ is realized by a map $f_\psi : (W, \partial W) \rightarrow S^1$ transverse to a given point $q \in S^1$. Denote by $j : \partial W \rightarrow W$ and $r : S \rightarrow \partial W$ the two inclusions. Then $\gamma := j^t(\psi)$ is realized by the restriction f_γ of f_ψ to ∂W , while the restriction of f_γ to S realizes $(j \circ r)^t(\phi)$ and is homotopic to the identity. Up to modify the given trivialization h_0 by a suitable one say h , f_γ factorizes as $p \circ h$, where $h : \partial W \rightarrow Y \times S^1$ and $p : Y \times S^1 \rightarrow S^1$ is the projection onto the second factor. Then $(Z, \partial Z) = (f_\phi^{-1}(q), f_\gamma^{-1}(q))$ and \tilde{Z} obtained by gluing along ∂Z the mapping cylinder of the restriction of π to it achieve the proof.

□

From the last step of the above proof we have the following corollary.

COROLLARY 13.8. *Let X be an oriented compact n -manifold with boundary ∂X . Let Z be a proper oriented submanifold of dimension $n - 2$ of ∂X . Assume that $[Z] = 0$ in $\mathcal{H}^2(X; \mathbb{Z})$. Then there is a proper oriented hypersurface $(W, \partial W)$ such that $Z = \partial W$.*

We have also the following version of Corollary 13.8 when Z is of codimension 2 in ∂X .

PROPOSITION 13.9. *Let X be an oriented compact n -manifold with boundary ∂X . Let Z be a proper submanifold of dimension $n - 3$ of ∂X . Assume that $[Z] = 0$ in $\mathcal{H}^3(X; \mathbb{Z})$. Then there is a proper codimension-2 oriented submanifold $(W, \partial W)$ of $(X, \partial X)$ such that $Z = \partial W$.*

Proof : The hypotheses put us in a situation analogous to the last step in the proof of Proposition 13.7, that is to Corollary 13.8. Here S^1 is replaced by $\mathbf{P}^n(\mathbb{C})$ (n big enough) in the sense that both carry special instances of the *Pontryagin-Thom's construction* which will be considered in Chapter 17 in full generality. Let $f_0 : Z \rightarrow \mathbf{P}^{n-1}(\mathbb{C})$ be a classifying map of the oriented normal rank-2 bundle of Z in ∂X . Note that $\mathbf{P}^n(\mathbb{C}) \setminus \{x_0\}$, $x_0 \in \mathbf{P}^n(\mathbb{C}) \setminus \mathbf{P}^{n-1}(\mathbb{C})$, is diffeomorphic to the total space of the tautological vector bundle on $\mathbf{P}^{n-1}(\mathbb{C})$. Hence f_0 extends to a map $f : \partial X \rightarrow \mathbf{P}^n(\mathbb{C})$ such that $f \pitchfork \mathbf{P}^{n-1}(\mathbb{C})$ and $Z = f^{-1}(\mathbf{P}^{n-1}(\mathbb{C}))$. As $[Z] = 0$ in $\mathcal{H}^3(X; \mathbb{Z})$, if n is big enough then f can be extended to a map $F : X \rightarrow \mathbf{P}^n(\mathbb{C})$ which we can assume transverse to $\mathbf{P}^{n-1}(\mathbb{C})$. Finally $W = F^{-1}(\mathbf{P}^{n-1}(\mathbb{C}))$ does the job.

□

As a corollary we have a weak version of Proposition 13.7 when Y has codimension 3.

COROLLARY 13.10. *Let $Y \subset X$ be a proper oriented codimension 3 submanifold of X . Assume that the normal bundle of Y in X has a non vanishing section s and let $Y' = s(Y)$ be a copy of Y in the boundary ∂U of a tubular neighbourhood of Y in X . Assume that $[Y'] = 0$ in $\mathcal{H}^3(X \setminus \text{Int}(U); \mathbb{Z})$. Then there is a proper oriented codimension-2 submanifold $(W, \partial W)$ of $(X \setminus \text{Int}(U), \partial U)$ such that $\partial W = Y'$.*

REMARK 13.11. (*Non orientable Seifert surfaces*) In the statement of Proposition 13.7 do not assume that X and Y are orientable and use $\mathcal{H}^2(X; \mathbb{Z}/2\mathbb{Z})$ instead. It is natural to inquire about the existence of possibly non orientable Seifert surface. We see an immediate obstruction: if a Seifert surface exists and $i^*(T(X)) = T(Y) \oplus \xi$ is as above (where ξ is now not necessarily trivial nor orientable), then ξ has a nowhere vanishing section. The above proof can be adapted to show that this is really the only obstruction.

Euler-Poincaré characteristic

X will denote a compact connected oriented boundaryless smooth n -manifold. Then also the tangent bundle $\pi : T(X) \rightarrow X$ is tautologically an *oriented* rank n vector bundle on X : the orientation of X determines in a coherent way an orientation on every fibre $T_p X$ of $T(X)$. Then we can consider the oriented Euler class

$$e^n(X) \in \Omega^n(X) = \mathcal{B}^n(X; \mathbb{Z}) = \mathbb{Z} .$$

By a traditional change of notation

$$\chi(X) := e^n(X) \in \mathbb{Z}$$

is called the *Euler-Poincaré characteristic of X* . If X is not connected, $\chi(X)$ is defined as the sum of the characteristics of its connected components.

Recall that $\chi(X)$ is computed by means of any section s of $T(X)$ transverse to X . In other words, $\chi(X)$ is the *self-intersection number* of X in $T(X)$. Such a section $s \pitchfork X$ is a tangent vector fields on X with only *non-degenerate zeros*: s can be expressed in local coordinates at every such a zero $p \sim 0$ in the form

$$s(x) = (x, f_p(x))$$

where $f_p : (\mathbb{R}^n, 0) \rightarrow (\mathbb{R}^n, 0)$ is a diffeomorphism. The sign $\epsilon(p) = \pm 1$ of the zero p , so that

$$\chi(X) = \sum_{p: s(p)=0} \epsilon(p)$$

is readily computed as

$$\epsilon(p) = \text{sign}(\det d_0 f_p) .$$

14.1. E-P characteristic via Morse functions

Let $f : X \rightarrow \mathbb{R}$ be a Morse function with critical points p_1, \dots, p_r of index q_1, \dots, q_r . Let $\nabla_g f$ be an adapted gradient field of f as in Section 9.1. Then p_1, \dots, p_r are also the zeros of this field. It is easy to check by using the Morse local coordinates that they are non degenerate zeros and their sign is given by

$$\epsilon(p_j) = (-1)^{q_j} .$$

Hence we have

$$\chi(X) = \sum_{j=1}^r (-1)^{q_j} .$$

This has the following interesting corollary.

COROLLARY 14.1. *If $\dim(X) = n$ is odd, then $\chi(X) = 0$.*

Proof : Consider the Morse function $1 - f$; f and $1 - f$ have the same critical points p_1, \dots, p_r , of index q_j and $n - q_j$, $j = 1, \dots, r$, respectively. Then

$$\chi(X) = \sum_{j=1}^r (-1)^{q_j} = \sum_{j=1}^r (-1)^{n-q_j}$$

as n is odd, this implies that $\chi(X) = -\chi(X)$.

□

REMARK 14.2. If we consider the handle decomposition of X , say \mathcal{H} , associated to a Morse function f , the above expression of $\chi(X)$ can be rephrased in terms of handle indices, that is $\chi(X) = \chi(\mathcal{H})$ (see Section 9.3). The characteristic $\chi(\mathcal{H})$ is defined for every handle decomposition, not necessarily associated (a priori) to any Morse function. We know that it is invariant for the (handle) move-equivalence.

14.2. The index of an isolated zero of a tangent vector field

We are going to reformulate the sign $\epsilon(p)$ of a non degenerate zero of a tangent vector field on X in a way which will make sense also for any *isolated* zero (not necessarily non degenerate). Let p be an isolated zero of a vector field s . Let us implement the following procedure:

- (1) Take local coordinates of X at $p \sim 0$, so that s is of the form

$$s(x) = (x, f_p(x))$$

where

$$f_p : (\mathbb{R}^n, 0) \rightarrow (\mathbb{R}^n, 0)$$

is a smooth map such that $f_p^{-1}(0) = \{0\}$.

- (2) Then it is well defined the smooth map

$$f_p/\|f_p\| : S^{n-1} \rightarrow S^{n-1} .$$

- (3) We can assume that the standard orientation of \mathbb{R}^n associated to the standard basis is coherent with the global orientation of X , so that S^{n-1} is oriented as the boundary of the oriented disk $D^n \subset \mathbb{R}^n$.
- (4) Finally set

$$i_p = \deg(f_p/\|f_p\|) \in \mathbb{Z} .$$

A priori this might depend on the particular choices made in the implementation.

We have

LEMMA 14.3. (1) $i_p(s) := i_p = \deg(f_p/\|f_p\|) \in \mathbb{Z}$ is well defined (i.e. it does not depend on the specific implementation of the procedure) and is called the index of the isolated zero p of the tangent vector field s .

- (2) If p is a non degenerate zero of s , then (with the notations fixed above)

$$i_p(s) = \epsilon(p) = \text{sign}(\det d_0 f_p) .$$

Proof : Let $\phi : (\mathbb{R}^n, 0) \rightarrow (\mathbb{R}^n, 0)$ be a change of coordinates relating two different implementations. Then $\mathcal{D}^n := \phi^{-1}(D^n)$ is a smooth oriented n -disk around 0, with oriented boundary Σ diffeomorphic to S^{n-1} . Let $s(x) = (x, f_p(x))$ be the expression of s in the source local coordinates. Set

$$g := f_p/\|f_p\| : \mathbb{R}^n \setminus \{0\} \rightarrow S^{n-1} .$$

It is clear that i_p computed with respect to the target local coordinates is equal to the degree of the restriction of g to Σ . So we have to prove that this degree equals i_p computed with respect to source local coordinates. There is $1 > \epsilon > 0$ small enough such that the closed n -disk ϵD^n (with boundary ϵS^{n-1}) is contained in the interior of \mathcal{D}^n . Then the restriction of g to $D^n \setminus \text{Int}(\epsilon D^n)$ establishes an oriented bordism of $g|_{S^{n-1}}$ with $g|_{\epsilon S^{n-1}}$; similarly the restriction of g to $\mathcal{D}^n \setminus \text{Int}(\epsilon D^n)$ establishes a bordism of $g|_{\Sigma}$ with $g|_{\epsilon S^{n-1}}$. Then we can conclude by applying twice the invariance of the degree up to bordism. This achieves (1).

As for (2), assume that f_p is a diffeomorphism. The result is immediate if f_p is a linear isomorphism. Then we can conclude by means of the results of Section 1.14 and the invariance properties of the degree again.

□

14.3. Index theorem

Let s be a tangent vector field on X with only isolated zeros, say p_1, \dots, p_r (there is a finite number because X is compact). Then we can set

$$\chi(X, s) = \sum_{j=1}^r i_{p_j}(s) ;$$

if $s \pitchfork X$, that is all zeros are non degenerate, then we know that

$$\chi(X, s) = \chi(X)$$

has an intrinsic meaning, not depending on the field s . Next theorem extends this fact to an arbitrary field as above.

THEOREM 14.4. *For every tangent vector field s on X with only isolated zeros, we have*

$$\chi(X, s) = \chi(X) .$$

Proof : For every zero p_j of s fix an implementation of the procedure that computes $i_{p_j}(s)$. Hence $i_{p_j}(s) = \text{deg}(g_j : S_j^{n-1} \rightarrow S^{n-1})$. We can also assume that these charts are pairwise disjoint. Let \tilde{s} be a section of $T(X)$, $\tilde{s} \pitchfork X$, very close to s . Then the non degenerate zeros of \tilde{s} distribute in bunches $z_{j,1}, \dots, z_{j,r_j}$, contained in the interior of the n -disk D_j^n , $j = 1, \dots, r$. Fix one of these zeros $p = p_j$ and consider the corresponding $z_1, \dots, z_{r_j} \in D^n = D_j^n$. We can take a system of pairwise disjoint small n -disks D_i^n centred at z_i , contained in the interior of D^n . As s and \tilde{s} are homotopic along $S^{n-1} = \partial D^n$, then we can use \tilde{s} instead of s in order to compute $i_{p_j}(s)$ via the degree. On the other hand, we can use the restriction of \tilde{s} to ∂D_i^n in order to compute the index of the non degenerate zero z_i of \tilde{s} . The normalized field is defined on $D^n \setminus (\cup_i \text{Int}(D_i^n))$ and this establishes a bordism between the restriction on the boundary components. By the invariance of the degree up to bordism, we realize that

$$i_p(s) = \sum_i i_{z_i}(\tilde{s}) .$$

By taking the sum over all zeros of s we eventually get

$$\chi(X, s) = \sum_{j,i} i_{z_{j,i}}(\tilde{s}) = \chi(X) .$$

□

14.4. E-P characteristic for non oriented manifolds

Let us fix first the behaviour of χ with respect to the change of orientation. So let X be as above and $-X$ denotes it endowed with the opposite orientation.

LEMMA 14.5. $\chi(X) = \chi(-X)$.

Proof : Use a same given tangent field s with isolated zeros to compute both characteristic numbers. As $T(X)$ is tautologically oriented in agreement with the orientation of X , it is immediate that the index of every zero of s does not depend on the choice of this orientation.

□

In fact the computation of the index of an isolated zero p of s is a purely local stuff:

One does not really need a global orientation of X to compute it; a local orientation of X at p suffices and the same argument of the above lemma shows that it does not depend on the choice of such local orientation.

This suggests that the procedure to compute $\chi(X)$ can be extended to every X not oriented and even non orientable; it is enough to replace in the computation

of the indices a global orientation of X (if any) with an arbitrary system of local orientations at the zeros of a given tangent field s with isolated zeros. Then we have defined in general $\chi(X, s)$, which a priori depends on the choice of s . In fact it does not. If X is orientable we have already achieved this result. Assume that X is connected and non orientable. Let $p : \tilde{X} \rightarrow X$ be the degree 2 orientation covering of X , where \tilde{X} is the connected orientable total space of the unitary determinant bundle of X . Every field s on X as above lifts to a field \tilde{s} on \tilde{X} so that every isolated zero p of s lifts to a couple p_{\pm} of isolated zeros of \tilde{s} . It follows from the very definition that

$$i_p(s) = i_{p_{\pm}}(\tilde{s})$$

so eventually

$$\chi(X, s) = \frac{1}{2}\chi(\tilde{X}, \tilde{s}) = \frac{1}{2}\chi(\tilde{X}) .$$

Recall that if X is orientable then \tilde{X} consists of two copies of X so that also in this case

$$\chi(X) = \frac{1}{2}\chi(\tilde{X}) .$$

Summing up

$$\chi(X) := \frac{1}{2}\chi(\tilde{X}) \in \mathbb{Z}$$

is always a well defined characteristic number of X , and in every case (X being orientable or not) can be computed as the sum of indices of any tangent vector field s on X with isolated zeros.

Recall that we have also the non oriented cobordism Euler class

$$w^n(X) \in \eta^n(X) = \mathcal{B}^n(X; \mathbb{Z}/2\mathbb{Z}) = \mathbb{Z}/2\mathbb{Z} .$$

Clearly

$$w^n(X) = \chi(X) \pmod{2}$$

and sometimes one writes

$$\chi_{(2)}(X) := w^n(X) .$$

14.5. Some examples and properties of χ

- The unit sphere S^n admits a Morse function with just one minimum and one maximum, then

$$\chi(S^n) = 1 + (-1)^n$$

and it is zero when n is odd (as it must be), while $\chi(S^n) = 2$ if n is even. This implies that an even dimensional sphere does not admit any nowhere vanishing tangent vector field. In fact we have

S^n admits a nowhere vanishing tangent vector field if and only if n is odd.

We have to exhibit such a tangent vector field on S^n when n is odd. For $n = 1$, let $S^1 \subset \mathbb{R}^2$ the unit circle. For every $p = (x, y) \in S^1$, set $s(p) = (-y, x)$, this does the job. In general for every $p = (x_1, y_1, \dots, x_{n+1}, y_{n+1}) \in S^n \subset \mathbb{R}^{n+1}$, set $s(p) = (-y_1, x_1, \dots, -y_{n+1}, x_{n+1})$.

- If $\pi : \tilde{X} \rightarrow X$ is a degree d covering map, then

$$\chi(\tilde{X}) = d\chi(X) .$$

In fact we can argue as made above for the degree 2 covering maps, by lifting to \tilde{X} any tangent vector field s with isolated zeros on X ; every zero p of s lifts to d isolated zeros of \tilde{s} sharing the same index of $i_p(s)$. In particular by considering the natural degree 2 covering map $\pi : S^n \rightarrow \mathbf{P}^n(\mathbb{R})$, we have $\chi(\mathbf{P}^n(\mathbb{R})) = 0$ if n is odd, while $\chi(\mathbf{P}^n(\mathbb{R})) = 1$ if n is even.

• Consider the complex projective space $\mathbf{P}^n(\mathbb{C})$ as the quotient space of the unitary sphere $S^{2n+1} \subset \mathbb{C}^{n+1}$. One verifies (do it by exercise by using the standard atlas of $\mathbf{P}^n(\mathbb{C})$ with $n + 1$ complex affine charts) that

$$f([z_0, z_1, \dots, z_n]) = \sum_{j=0}^n (j + 1) |z_j|^2$$

defines a Morse function on $\mathbf{P}^n(\mathbb{C})$ with exactly $n + 1$ critical points

$$p_0 = [1, 0, \dots, 0], \dots, p_n = [0, \dots, 0, 1]$$

and every even index between 0 and $2n$ occurs exactly once. Hence

$$\chi(\mathbf{P}^n(\mathbb{C})) = n + 1 .$$

• The characteristic χ is *multiplicative with respect to the product of manifolds*. That is, if X and X' are compact boundaryless manifold as above, then

$$\chi(X \times X') = \chi(X)\chi(X') .$$

In fact if s (s') is a tangent field on X (on X') with non degenerate zeros p_1, \dots, p_r ($p'_1, \dots, p'_{r'}$), then $s \times s'$ defines a field on $X \times X'$ with rr' non degenerate zeros (p_j, p'_i) , $j = 1, \dots, r$, $i = 1, \dots, r'$, each one having index

$$i_{(p_j, p'_i)}(s \times s') = i_{p_j}(s) i_{p'_i}(s') .$$

For example

$$\chi(X \times S^1) = 0$$

for every X (in fact we can explicitly define a nowhere vanishing tangent vector field on $X \times S^1$ which restricts to the above standard field on every fibre $\sim S^1$).

Whenever both n and m are even, then

$$\chi(\mathbf{P}^n(\mathbb{R}) \times \mathbf{P}^m(\mathbb{R})) = 1 .$$

14.6. The relative E-P characteristic of a triad, χ -additivity

Here we adopt the setting of Chapter 9. By definition a *relative tangent vector field on a triad* (W, V_0, V_1) of compact smooth manifolds, at the boundary $\partial W = V_0 \amalg V_1$ looks like a gradient of a smooth function $f : W \rightarrow [0, 1]$ such that $V_j = f^{-1}(j)$, $j = 0, 1$, and has no critical points on a neighbourhood of ∂W . Hence it is ingoing W along V_0 and outgoing along V_1 . An adapted gradient of any Morse function on the triad is a typical example of such a field. By using these fields we can develop with minor changes a notion of *relative of E-P characteristic for triads*. Assuming first that W is oriented (with oriented boundary), by using relative fields with only non degenerate zeros we can define the self-intersection number

$$\chi(W, V_0) \in \mathbb{Z}$$

of W in $T(W)$ relatively to V_0 ; it is well defined as does not depend on the choice of the non degenerate field. Then we can extend the Hops index theorem which allows us to compute $\chi(W, V_0)$ by means of any relative field with isolated zeros; finally we can extend the definition of $\chi(W, V_0) \in \mathbb{Z}$ to non oriented and even non orientable triads. Of course every W with non empty boundary gives rise to several triads (W, V_0, V_1) ; among these: $(W, \emptyset, \partial W)$ and $(W, \partial W, \emptyset)$. The notation

$$\chi(W) := \chi(W, \emptyset, \partial W)$$

is compatible with

$$\chi(W) = \chi(W, \emptyset, \emptyset)$$

when W is boundaryless.

If $f : W \rightarrow [0, 1]$ is a Morse function on the triad (W, V_0, V_1) , then $\hat{f} = 1 - f$ is a Morse function on (W, V_1, V_0) . By using respective adapted gradient fields to compute the relative characteristics we get

LEMMA 14.6.

$$\chi(W, V_0) = (-1)^{\dim(W)} \chi(W, V_1) .$$

□

Note that $\chi(D^n) = 1$: use a Morse function on $(D^n, \emptyset, S^{n-1})$ with just one minimum.

If X is boundaryless and Y is with boundary, then the very same argument used when also Y is boundaryless allows to extend the multiplicative property.

LEMMA 14.7.

$$\chi(X \times Y) = \chi(X)\chi(Y) .$$

In particular

$$\chi(X \times D^n) = \chi(X) .$$

□

14.6.1. Additive property of χ . If (W, V_0, V_1) , (W', V'_0, V'_1) are triads and $\phi : V_1 \rightarrow V'_1$ is a diffeomorphism, we get a new composite triad (W'', V_0, V'_1) , where $W'' = W \amalg_{\phi} W'$. Any couple of relative fields v and v' with isolated zeros on the given two triads respectively, can be glued together to produce a relative field v'' having as zeros the union of the zeros of v and v' each one keeping its index. Then we have

$$\chi(W'', V_0, V'_1) = \chi(W, V_0, V_1) + \chi(W', V'_0, V'_1) .$$

This additive property of χ has remarkable consequences.

14.6.2. A baby TQFT. In Section 10.8 we have roughly outlined the axioms of a so called TQFT and posed the question about the existence of any “non trivial” one. Here we use χ to provide a baby but non trivial example. Consider $\mathbf{CAT}_{\eta}(n+1)$. Associate to every object M the vector space $Z(M) = \mathbb{C}$. To every arrow f carried by any triad (W, M_0, M_1) , associate the unitary \mathbb{C} -linear map

$$Z(f) : Z(M_0) \rightarrow Z(M_1), \quad z \rightarrow e^{i\chi(W, M_0)} z .$$

By using the additive property of χ it is easy to check that all axioms are verified. This shows at least that there are not logical contradictions within the given pattern of axioms.

14.7. E-P characteristic of tubular neighbourhoods and the Gauss map

The above equality $\chi(X \times D^n) = \chi(X)$ is a special case of the following

PROPOSITION 14.8. *Let $p : U \rightarrow X$ be a closed tubular neighbourhood of a submanifold X of some Y . Then $\chi(U) = \chi(X)$.*

Proof : It is enough to show the equality for an ϵ -neighbourhood $N_{\epsilon}(X)$ of the zero section X of a vector bundle $\pi : E \rightarrow X$ endowed with a field of positive definite scalar products on every fibre. Let v be a tangent field on X with non degenerate zeros. Define the field on $N_{\epsilon}(X)$

$$w(z) = (z - p(z)) + v(p(z)) .$$

One checks that w is a field on the triad $(N_{\epsilon}(X), \emptyset, \partial N_{\epsilon}(X))$, the zeros of w coincide with the zeros of v , are non degenerate and keep the sign. The Proposition follows. □

In the special case $X \subset \mathbb{R}^k$, assume that U has been constructed by means of the standard metric on \mathbb{R}^k . By removing from the interior of U a system of

pairwise disjoint small open disks \mathcal{D}_p around every zero of w , we get a manifold W with boundary $(\coprod_p S_p^{k-1}) \amalg \partial U$ on which the normalized field $\mathbf{w} := w/|w|$ is well defined, as well as the map $\mathbf{w} : W \rightarrow S^{k-1}$. The restriction of \mathbf{w} to ∂U is a field of unitary vectors pointing out from U (in fact normal to the boundary). This restriction, say $g_{\partial U}$ is called the *Gauss map of the hypersurface ∂U* . By computing the characteristic as sum of zero indices and by means of the bordism invariance of the degree, finally we have

COROLLARY 14.9. *Let $p : U \rightarrow X$ be a tubular neighbourhood of X in \mathbb{R}^k . Then*

$$\chi(X) = \deg(g_{\partial U})$$

where $g_{\partial U}$ is the Gauss map of the hypersurface ∂U .

□

If X itself is an oriented hypersurface in \mathbb{R}^k , we can define its Gauss map $g_X : X \rightarrow S^{k-1}$ as the unitary field of normal vectors along X such that followed by the orientation of X produce the given (standard) orientation of \mathbb{R}^k along X . In this case ∂U consists of two parallel copies of X with opposite orientations. The last corollary specializes to

COROLLARY 14.10. *Let X be an oriented hypersurface of \mathbb{R}^k then*

$$\chi(X) = 2 \deg(g_X)$$

where g_X is the Gauss map of X .

□

REMARK 14.11. We can compute inductively the characteristic of real and complex projective spaces by decomposing $\mathbf{P}^n(K)$ as the union of a tubular neighbourhood of $\mathbf{P}^{n-1}(K) \subset \mathbf{P}^n(K)$ and its complement, and applying Proposition 14.8 together with the additivity of χ .

14.8. Non triviality of η_\bullet and Ω_\bullet

The integer E-P characteristic is *not* invariant up to bordism. For example $[S^2] = [S^1 \times S^1] = 0 \in \eta^2$, but $\chi(S^2) = 2 \neq 0 = \chi(S^1 \times S^1)$. On the other hand the E-P characteristic mod(2) is bordism invariant.

PROPOSITION 14.12. *Let $[X] = 0 \in \eta^n$. Then $\chi_{(2)}(X) = 0 \in \mathbb{Z}/2\mathbb{Z}$.*

Proof : If n is odd, we know in general that $\chi(X) = 0$. Assume that n is even. Let $X = \partial W$, W being a compact manifold with boundary. Take the double $D(W)$. $D(W)$ can be presented as the composition of the triad

$$(X \times D^1, \emptyset, (X \times \{-1\}) \amalg (X \times \{1\}))$$

followed by two copies of the triad

$$(W, X, \emptyset)$$

glued to $X \times D^1$ along $X \times \{\pm 1\}$ respectively. By the additive property

$$\chi(D(W)) = \chi(X \times D^1) + 2\chi(W, X, \emptyset) .$$

By Lemmas 14.7, 14.6 and the facts that $n+1$ is odd and the double is boundaryless we have

$$\chi(X) = \chi(D(W)) - 2\chi(W, X, \emptyset) = 2\chi(W) \in \mathbb{Z}$$

so that

$$\chi_{(2)}(X) = 0 \in \mathbb{Z}/2\mathbb{Z} .$$

□

As an immediate corollary we have the *non triviality of η_{2n} and Ω_{4n}* .

COROLLARY 14.13. *For every even $n \geq 1$, $\eta_{2n} \neq 0$ and $\Omega_{4n} \neq 0$*

Proof : We know that $\chi(\mathbf{P}^{2n}(\mathbb{R})) = 1$, hence $[\mathbf{P}^{2n}(\mathbb{R})] \neq 0 \in \eta_{2n}$. Similarly $\chi_{(2)}(\mathbf{P}^{2n}(\mathbb{C})) = 1$, hence $[\mathbf{P}^{2n}(\mathbb{C})] \neq 0 \in \Omega_{4n}$. \square

By using the multiplicative property of χ and the obvious fact that it is additive under disjoint union we also have

COROLLARY 14.14. $\chi_{(2)} : \eta^\bullet \rightarrow \mathbb{Z}/2\mathbb{Z}$ is a well defined non trivial ring homomorphism.

\square

In fact every $\mathbf{P}^a(\mathbb{R}) \times \mathbf{P}^b(\mathbb{R})$, a, b even, is non trivial in η_{a+b} . For example in η_4 we have the non trivial $[\mathbf{P}^4(\mathbb{R})]$, $[\mathbf{P}^2(\mathbb{R}) \times \mathbf{P}^2(\mathbb{R})]$, $[\mathbf{P}^2(\mathbb{C})]$. At present we are not able to decide if they are equal or not. Similarly we have that $\mathbf{P}^a(\mathbb{C}) \times \mathbf{P}^b(\mathbb{C})$, a, b even, is non trivial in $\Omega_{2(a+b)}$.

14.9. Combinatorial E-P characteristic

We have treated the E-P characteristic of smooth manifolds in purely differential/topological terms. However, the reader is probably aware that the name E-P characteristic is used in other different settings. Probably she/he has at least encountered a combinatorial formula producing the value $2 = \chi(S^2)$ for every polyhedral realization of the sphere as the boundary of a convex polytope in \mathbb{R}^3 . In this very sketchy Section we would outline a few bridges between such different ways to recover the E-P characteristic.

14.9.1. Piecewise smooth triangulations and the combinatorial characteristic. Recall that a m -simplex σ in some euclidean space \mathbb{R}^h , $h \geq m$ is the convex hull of $m+1$ affinely independent points (that is they span an m -dimensional affine subspace of \mathbb{R}^h). These are called the *vertices* of σ . By removing one vertex, say p , we determine a $(m-1)$ simplex σ_p which is the $(m-1)$ face of σ opposite to the vertex p . By iterating the face operation we get the iterated k -faces of σ , $0 \leq k \leq m$, where the vertices are the 0-faces and σ itself is the unique m -face. By definition a *finite simplicial complex* is a finite family \mathcal{K} of simplexes in some \mathbb{R}^h such that

- \mathcal{K} is closed with respect to the iterated faces.
- Two simplexes of \mathcal{K} may intersect each other only at a common iterated face.

The union $|\mathcal{K}|$ of the simplexes of \mathcal{K} is a subspace of \mathbb{R}^h called the *geometric support* of the complex \mathcal{K} .

Let X be a compact boundaryless smooth manifold. A *piecewise smooth triangulation* of X is given by a homeomorphism

$$\tau : |\mathcal{K}| \rightarrow X$$

where \mathcal{K} is a finite simplicial complex in some \mathbb{R}^h and the restriction of τ to every n -simplex of \mathcal{K} is a smooth embedding in X . If $\partial X \neq \emptyset$, we require furthermore that $\tau|_{\tau^{-1}(\partial X)}$ is a triangulation of ∂X .

One can prove

PROPOSITION 14.15. *Let $\tau : |\mathcal{K}| \rightarrow X$ be a piecewise smooth triangulation of the compact boundaryless smooth n -manifold X . Then there is a tangent, so called Whitney vector field v_τ on X whose zero set coincides with the set of images of the barycenters $\hat{\sigma}$ of the simplexes σ of \mathcal{K} and every zero has index equal to $(-1)^{\dim(\sigma)}$.*

As a Corollary of the above Proposition and the Index Theorem, we have

COROLLARY 14.16. *For every piecewise triangulation $\tau : |\mathcal{K}| \rightarrow X$ as above,*

$$\chi(X) = \sum_{j=0}^n (-1)^j c_j := \chi(\mathcal{K})$$

where c_j is the number of j dimensional simplexes of \mathcal{K} . In particular the combinatorial characteristic $\chi(\mathcal{K})$ does not depend on the choice of the triangulation of X .

□

A few comments about the proof. The Whitney field v_τ can be explicitly given by means of barycentric coordinates on the simplexes of \mathcal{K} , see for instance [HT]; every barycenter of a n -simplex of \mathcal{K} corresponds to a source of v_τ , every vertex of \mathcal{K} corresponds to a pit, in general every barycenter of a j -simplex corresponds to a saddle point with a j dimensional space of ingoing directions tangent to the simplex and a $n - j$ -dimensional space of outgoing directions tranverse to the simplex.

For the *existence* (and a suitable form of “uniqueness up to subdivision”) of piecewise smooth triangulations see [Mu].

14.9.2. Homological characteristic. Here we want to recover the combinatorial characteristic in an algebraic/topological setting.

Fix any field F (for example $F = \mathbb{Z}/2\mathbb{Z}, \mathbb{Q}, \mathbb{R}, \mathbb{C}$).

Given a triangulation of X as above, we can define the *simplicial homology of \mathcal{K} with coefficients in F* as follows:

- Give every simplex σ of \mathcal{K} an orientation, induced by the choice of an orientation on the affine subspace of \mathbb{R}^h spanned by the vertices of σ .
- For every $0 \leq j \leq n$, set $C_j(\mathcal{K}; F)$ the finite dimensional F -vector space having as a basis the oriented j -simplexes of \mathcal{K} (note that $-\sigma$ considered as the simplex endowed with the opposite orientation is confused with -1σ i.e. the product of σ with the scalar $-1 \in F$). Hence

$$\dim C_j(\mathcal{K}; F) = c_j .$$

- Every $(j - 1)$ -face σ' of the oriented j -simplex σ of \mathcal{K} inherits a boundary orientation accordingly with our usual convention. Hence σ' has two orientations, the one fixed above and the boundary orientation. Give it the sign $\epsilon(\sigma', \sigma) = 1$ if these orientations agree to each other, the sign -1 otherwise. Then define the unique F -linear map

$$\partial_j : C_j(\mathcal{K}; F) \rightarrow C_{j-1}(\mathcal{K}, F)$$

which on every oriented j -simplex σ holds:

$$\partial_j(\sigma) = \sum_{\sigma'} \epsilon(\sigma', \sigma) \sigma'$$

where σ' varies among the $(j - 1)$ faces of σ . It is not hard to verify that

$$\delta_{j-1} \circ \delta_j = 0$$

basically because two $(j - 1)$ faces of the oriented j -simplex σ both endowed with the boundary orientation, induce opposite boundary orientations on their common $(j - 2)$ face of σ . Hence we can define the quotient F -vector spaces

$$H_j(\mathcal{K}; F) = \ker(\delta_j) / \text{Im}(\delta_{j+1})$$

and these are the desired simplicial F -homology spaces of the complex \mathcal{K} . By using the elementary dimension formula for any finite dimensional linear map $f : V \rightarrow W$:

$$\dim(V) = \dim(\ker(f)) + \dim(\text{Im}(f))$$

it is not hard to check that the *F-homological characteristic*

$$\chi(H_{\bullet}(\mathcal{K}; F)) := \sum_{j=0}^n (-1)^j \dim H_j(\mathcal{K}; F) = \sum_{j=0}^n (-1)^j \dim C_j(\mathcal{K}; F)$$

hence it equals the combinatorial characteristic so that

$$\chi(H_{\bullet}(\mathcal{K}; F)) = \chi(X) .$$

Remarkably it does not depend on the choice of the triangulation of X and not even of the field F . It is a fundamental and basic result of algebraic topology (see [Hatch], [Mu2]) that even the single dimensions (also called the *F-Betti numbers* of X)

$$\dim H_j(X; F) := \dim H_j(\mathcal{K}; F)$$

do not depend on the choice of the triangulation, although they depend on F .

CHAPTER 15

Surfaces

We are going to apply several tools developed in the previous Chapters in order to classify the compact surfaces (i.e. smooth 2-manifolds) and also to determine both bordisms η_2 and Ω_2 .

Let M be a compact connected boundaryless surface.

- We know from Chapter 9 that

M admits a ‘reduced’ ordered handle decomposition with one 0-handle, followed by say κ disjoint 1-handles and one final 2-handle, where $\kappa := \kappa(M)$ is intrinsically determined by

$$\kappa(M) = 2 - \chi(M) .$$

In fact recall that for any handle decomposition \mathcal{H} of M , its characteristic

$$\chi(\mathcal{H}) := \sum_{j=0}^2 (-1)^j b(j)$$

$b(j)$ being the number of index j handles, is preserved by the basic moves on handle decompositions; if \mathcal{H} is associated to a Morse function on M , then $\chi(\mathcal{H}) = \chi(M)$; finally we can get a reduced ordered decomposition of M by performing some basic moves on any given decomposition.

REMARK 15.1. For any ordered handle decomposition of M with one 0-handle, one 2-handle and a few disjoint 1-handles, it is not hard to triangulate M in the following way: take a vertex internal to every handles; take as further vertices on the boundary of the 0-handle the union of the boundaries of the attaching 1-disks of the 1-handles; they also provide a triangulation of the boundary of every 1-handle; triangulate both the one 0-handle and every 1-handle by the cones on the boundary with centre at the respective internal vertex; these triangulations match and give a triangulation of the union of the 0-handle with the 1-handles; the resulting surface has as boundary a triangulated circle; finally complete it to a triangulation of the whole of M by means again of the cones with centre at the internal vertex of the 2-handle. By using the combinatorial computation of $\chi(M)$ applied to such a triangulation one can easily check that the number of 1-handles is always equal to $\kappa(M)$.

- Recall from Section 7.5.2 that

In dimension 2 connected sum and weak connected sum are equivalent to each other; moreover every twisted 2-sphere is diffeomorphic to the standard S^2 .

So let $\gamma \subset M$ be any dividing connected simple curve γ , that is

$$M \setminus \gamma = N_1 \amalg N_2$$

where N_j is a non empty connected open set of M and the closure \bar{N}_j is a compact smooth manifold with boundary $\partial\bar{N}_j = \gamma$; let M_j be the boundaryless surface obtained from \bar{N}_j by filling $\partial\bar{N}_j$ with a 2-disk glued along the boundary; then (up to diffeomorphism)

$$M \sim M_1 \# M_2 .$$

To be more precise, the result is uniquely determined if at least one among M_1 and M_2 is non orientable, or both are orientable and admit orientation reversing diffeomorphisms. In general let us say that M is “a” connected sum of M_1 and M_2 (this precision will be eventually immaterial). By the additive property of χ , we have

$$\kappa(M) = \kappa(M_1) + \kappa(M_2) .$$

- Let us consider $\eta_1(M) = \mathcal{B}_1(M; \mathbb{Z}/2\mathbb{Z})$.

LEMMA 15.2. $\eta_1(M)$ is $\mathbb{Z}/2\mathbb{Z}$ -vector space of finite dimension $\leq \kappa(M)$.

Proof : By Section 10.6 there is a *surjective* homomorphism (a base point being understood)

$$\pi_1(M) \rightarrow \eta_1(M) .$$

By using a reduced ordered handle decomposition of M as above and applying (an elementary version of) Van Kampen theorem we see that $\pi_1(M)$ has a presentation with κ generators and one relation; for the union of the 0-handle with the κ 1-handles has the homotopy type of a wedge of κ copies of S^1 whose fundamental group is a free group with κ generators; the defining relation between them is given by the attaching map of the 2-handle. The Lemma follows. \square

LEMMA 15.3. *Every $\alpha \in \eta_1(M)$ can be represented by a connected simple smooth curve C traced on M .*

Proof : We already know from general results in Chapter 13 that a codimension 1 class can be represented by hypersurfaces. In the present 2-dimensional situation we can get an elementary direct proof of this fact as follows. Certainly $\alpha = [f : \tilde{C} \rightarrow M]$ where \tilde{C} is a finite union of copies of S^1 . By a standard ‘general position’ argument (see Section 8.2) we can assume that up to homotopy, hence up to bordism, $f : \tilde{C} \rightarrow M$ is a generic immersion possibly having only simple double points in its image $f(\tilde{C}) \subset M$. In local coordinates every crossing of $f(\tilde{C})$ is of the form $\{xy = 0\}$ and has two local ‘simplifications’ of the form $\{xy \pm \phi(x, y)\epsilon = 0\}$ where $\epsilon > 0$ is small enough and ϕ is a suitable bump function with support in a small disk centred at 0. By locally simplifying every crossing of $f(\tilde{C})$ (choose arbitrarily one way) we get a 1-submanifold C' of M . It is not hard to verify that $\alpha = [f : \tilde{C} \rightarrow M] = [C'] \in \eta_1(M)$, this is left as an exercise. In general C' is not connected. In order to modify C' to get a connected representative C of α , first we can remove all dividing components of C' (keeping the name); if C' is not connected then apply the following argument that decreases the number of components by 1. We can find two components C_1 and C_2 of C' which can be connected by a smooth arc I whose internal part is embedded into $M \setminus C'$, one endpoint x_j is on C_j , $j = 1, 2$, and is tranverse to $C_1 \cup C_2$. I can be thickened to an embedded 1-handle $H \sim I \times [-1, 1]$ which intersects C_j at $\{x_j\} \times [-1, 1]$ and is contained in $M \setminus C'$ elsewhere. Then consider

$$C''' := (C' \setminus (C_1 \cup C_2)) \cup C^*$$

where

$$C^* = ((C_1 \cup C_2) \setminus H) \cup (I \times \{\pm 1\})$$

up to corner smoothing. Hence $C_1 \cup C_2$ has been replaced by the connected curve C^* . Again it is not hard to show that $[C'] = [C'''] \in \eta_1(M)$. By iterating the procedure we eventually get a required connected representative C of α . \square

- Consider now the symmetric intersection form (Section 11.4)

$$\bullet = \bullet_M : \eta_1(M) \times \eta_1(M) \rightarrow \mathbb{Z}/2\mathbb{Z} .$$

We have

LEMMA 15.4. *The intersection form on $\eta_1(M)$ is non degenerate.*

Proof : We have to show that if $\alpha \neq 0$ in $\eta_1(M)$, then there is $\beta \in \eta_1(M)$ such that $\alpha \bullet \beta = 1 \in \mathbb{Z}/2\mathbb{Z}$. Let $C \subset M$ be a connected smooth representative of α as in Lemma 15.3. As $\alpha \neq 0$, then $M \setminus C$ is connected (otherwise C would be the boundary of the closure of a component of $M \setminus C$, so that $[C] = 0$). Take a fibre I , necessarily tranverse to C at one point, of a tubular neighbour of C in M . Also $M \setminus (C \cup I)$ is connected, so that the endpoints of the interval I can be connected by a smooth simple arc γ whose internal part is contained in $M \setminus (C \cup I)$. Then (possibly by corner smoothing) $C' := I \cup \gamma$ is a smooth boundaryless curve in M which intersects C transversely at one point, hence $[C] \bullet [C'] = 1$. □

The next Lemma follows from Chapter 13 .

LEMMA 15.5. *Let $C \subset M$ be a connected smooth boundaryless curve. Then there are two possibilities: either $[C] \bullet [C] = 1$ and this happens if and only if C has tubular neighbourhood in M diffeomorphic to a Möbius band, or $[C] \bullet [C] = 0$ and this happens if and only if C has a product tubular neighbourhood in M .* □

The following Lemma is obvious

LEMMA 15.6. *If $f : M \rightarrow M'$ is a surface diffeomorphism, then*

$$f_* : (\eta_1(M), \bullet_M) \rightarrow (\eta_1(M'), \bullet_{M'})$$

is an isometry, that is f_ is a $\mathbb{Z}/2\mathbb{Z}$ -linear isomorphism and for every $\alpha, \beta \in \eta_1(M)$,*

$$\alpha \bullet_M \beta = f_*(\alpha) \bullet_{M'} f_*(\beta) .$$

□

Hence *the isometry class of the non degenerate symmetric intersection form on $\eta_1(*)$ is an invariant up to diffeomorphism.*

In what follows we will make the abuse of confusing a form with its isometry class. If (V, ρ) and (V', ρ') are finite dimensional $\mathbb{Z}/2\mathbb{Z}$ -vector spaces endowed with non degenerate symmetric forms, we can define the *orthogonal direct sum* $(V, \rho) \perp (V', \rho')$ which denotes the non degenerate symmetric form $\rho \perp \rho'$ on $V \oplus V'$ that restricts to ρ (resp. ρ') on V (V') and such that V and V' are orthogonal to each other. We have

LEMMA 15.7. *If the surface M is a connected sum*

$$M \sim M_1 \# M_2$$

then (up to isometry)

$$(\eta_1(M), \bullet_M) = (\eta_1(M_1), \bullet_{M_1}) \perp (\eta_1(M_2), \bullet_{M_2}) .$$

Proof : We can assume that the connected sum has been realized from a connected dividing curve γ in M as at the beginning of the section (we adopt those notations). It is easy to see that the linear map $i_* : \eta_1(N_j) \rightarrow \eta_1(M_j)$ induced by the inclusion is an isomorphism, $j = 1, 2$. Denote by V_j the image of $\eta_1(N_j)$ in $\eta_1(M)$ by the inclusion. It is evident that V_1 and V_2 are orthogonal to each other with respect to \bullet_M . It is enough to show that $\eta_1(M) = V_1 + V_2$, whence $\eta_1(M) = V_1 \perp V_2$ because \bullet_M is non degenerate, and that V_j is actually isomorphic to $\eta_1(N_j)$, $j = 1, 2$. Let $\alpha \in \eta_1(M)$ and $C \subset M$ be a smooth representative as above. By transversality we can assume that $C \pitchfork \gamma$. As $[\gamma] = 0$ in $\eta_1(M)$, then $C \cap \gamma$ consists of an even number of points $\{p_1, \dots, p_{2a}\}$. We can assume that they are the endpoints of a family $\{I_1, \dots, I_a\}$ of pairwise disjoint intervals embedded into γ . Take a 'small' tubular neighbourhood $U \sim \gamma \times [-1, 1]$ of γ in M . Then $M \setminus U$ consists of two connected components W_1 and W_2 such that $W_j \subset N_j$. The

boundary of W_j is a parallel copy γ_j of γ . Denote by $I_{i,j}$, $j = 1, 2$, $i = 1, \dots, d$, the parallel copy in γ_j of the interval I_i . Finally for $j = 1, 2$, set

$$C_j = (C \cap W_j) \cup \left(\bigcup_{i=1}^d I_{i,j} \right).$$

Up to corner smoothing, C_j is a smooth curve (not necessarily connected) in N_j and it is easy to see that

$$[C_1 \amalg C_2] = [C] \in \eta_1(M)$$

this shows that $\eta_1(M) = V_1 + V_2$. Finally let $\alpha \in \eta_1(N_1) \sim \eta_1(M_1)$ and denote by α' its image in $\eta_1(M)$ by the inclusion. If α is not zero, as \bullet_{M_1} is non degenerate, then there is $\beta \in \eta_1(N_1)$ such that $\alpha \bullet_{M_1} \beta = 1$; due to the geometric way one computes the intersection forms, it follows that also $\alpha' \bullet_M \beta' = 1$, whence α' is non zero. □

We are going to see that the isometry class of the intersection form contains all relevant information about the diffeomorphism class.

15.1. Classification of symmetric bilinear forms on $\mathbb{Z}/2\mathbb{Z}$

Here we classify up to isometry non degenerate symmetric bilinear forms on finite dimensional $\mathbb{Z}/2\mathbb{Z}$ -vector spaces. We denote by \mathbf{U} the unique 1 dimensional isometry class; by \mathbf{H} the isometry class of *hyperbolic planes*, i.e. 2-dimensional spaces endowed with a non degenerate symmetric form admitting a basis made by isotropic vectors (recall that a vector v is *isotropic* for a form β if $\beta(v, v) = 0$). Note that although \mathbf{H} is non degenerate it is *totally isotropic* (every vector is so), this depends on the fact that the characteristic of the field $\mathbb{Z}/2\mathbb{Z}$ is equal to 2, in characteristic $\neq 2$ the zero form is the only totally isotropic one by the so called ‘polarization formula’. For every $n \geq 1$, denote by $n\mathbf{U}$ (resp. $n\mathbf{H}$) the orthogonal direct sum of n copies of \mathbf{U} (resp. of \mathbf{H}). We have

PROPOSITION 15.8. *Let (V, β) be a finite dimensional $\mathbb{Z}/2\mathbb{Z}$ -vector space endowed with a non degenerate symmetric bilinear form, $\dim V > 0$. Then we have one of the following exclusive occurrences:*

(1) (V, β) admits an orthogonal basis so that it is isometric to $n\mathbf{U}$, $n = \dim V$, and this happens if and only if it is not totally isotropic.

(2) $\dim V = 2n$, (V, β) is isometric to $n\mathbf{H}$, and this happens if and only if it is totally isotropic.

Proof : Assume first that (V, β) is totally isotropic. Let $\mathcal{B} = \{v_1, \dots, v_k\}$ be a basis of V , $\mathcal{B}^* = \{v_1^*, \dots, v_k^*\}$ its dual basis, w_1 the vector which represents the functional v_1^* by means of the non degenerate form β . Then the subspaces spanned by $\{v_1, w_1\}$ endowed with the restriction of β is a hyperbolic plane \mathbf{H} . As this last is non degenerate, then (up to isometry)

$$(V, \beta) = \mathbf{H} \perp \mathbf{H}^\perp$$

all spaces being endowed with the restriction of β . Clearly also the restriction to \mathbf{H}^\perp is non degenerate and totally isotropic, $\dim \mathbf{H}^\perp = \dim V - 2$. So we can achieve the item (2) by induction on the dimension. Assume now that $v \in (V, \beta)$ is not isotropic. Then the subspace spanned by v endowed with the restriction of β represents \mathbf{U} and (up to isometry)

$$(V, \beta) = \mathbf{U} \perp \mathbf{U}^\perp.$$

By iterating the argument we get that either

$$(V, \beta) = n\mathbf{U}, \quad n = \dim V$$

and we have done, or

$$(V, \beta) = k\mathbf{U} \perp T$$

for some $k \geq 1$ where T is totally isotropic, $\dim T > 0$. We apply (2) to T , and get

$$(V, \beta) = k\mathbf{U} \perp h\mathbf{H}$$

for some $k, h \geq 1$. Finally item (1) is achieved by means of the following Lemma. Note by the way that it also shows that \perp does not verify the ‘cancellation properties’.

LEMMA 15.9. *Up to isometry $\mathbf{U} \perp \mathbf{H} = 3\mathbf{U}$.*

Proof : Let $\mathcal{D} = \{u, w, t\}$ be a basis for $\mathbf{U} \perp \mathbf{H}$ adapted to the decomposition so that $\{w, t\}$ is a basis of the hyperbolic plane. Let N be the subspace spanned by $\{u + w, u + t\}$. One readily verifies that this last is a orthogonal basis of N so that $N = 2\mathbf{U}$. Then $\mathbf{U} \perp \mathbf{H} = N \perp N^\perp$ and the last space is 1 dimensional and non degenerate, so eventually $\mathbf{U} \perp \mathbf{H} = 3\mathbf{U}$. □

Also the proof of Proposition 15.8 is now complete. □

15.2. Classification of compact surfaces

We are going to prove the following topological classification theorem.

THEOREM 15.10. *(0) Let M be a compact connected boundaryless surface. Then the following facts are equivalent to each other.*

- M is diffeomorphic to S^2 ;
- $\kappa(M) = 0$;
- $\dim \eta_1(M) = 0$.

(1) For every $n \geq 1$, the isometry class $n\mathbf{U}$ is realized by the intersection form of $\eta_1(n\mathbf{P}^2(\mathbb{R}))$ where $n\mathbf{P}^2(\mathbb{R})$ denotes the connected sum of n copies of the real projective plane.

(2) For every $n \geq 1$, the isometry class $n\mathbf{H}$ is realized by the intersection form of $\eta_1(n(S^1 \times S^1))$, where $n(S^1 \times S^1)$ denotes the connected sum of n copies of the torus.

(3) Two compact connected boundaryless surfaces M and M' are diffeomorphic if and only if the intersection forms on $\eta_1(M)$ and $\eta_1(M')$ respectively are isometric to each other.

This theorem has several interesting corollaries.

COROLLARY 15.11. *In the hypotheses of Theorem 15.2:*

(1) $\dim \eta_1(M) = \kappa(M) = 2 - \chi(M)$. If M is orientable then $\kappa(M) = 2g(M)$ is even ($g(M)$ is called the genus of M).

(2) Two surfaces M and M' are diffeomorphic if and only if $\chi(M) = \chi(M')$ and either they are both orientable or non orientable.

(3) Every orientable surface M admits orientation reversing diffeomorphisms. Hence the connected sum of two surfaces $M = M_1 \# M_2$ is always uniquely defined up to diffeomorphism.

(4) Every M can be embedded into \mathbb{R}^4 . If M is orientable then it can be embedded into \mathbb{R}^3 .

Proofs. First item (0) of Theorem 15.10, that is the characterization of the 2-sphere up to diffeomorphism. If $\kappa(M) = 0$, then M has a handle decomposition with only one 0-handle and one 2-handle. So it is a twisted 2-sphere, whence it is diffeomorphic to S^2 . Then M is simply connected, hence $\dim \eta_1(M) = 0$. Let us show now that if $\kappa(M) > 0$ then $\dim \eta_1(M) > 0$. Take a reduced ordered handle decomposition with $\kappa(M)$ 1-handles. The core of every 1-handle can be completed with a simple arc embedded into the 0-handle to get a connected simple smooth curve C in M . There are two possibilities: either for one such a curve $[C] \bullet_M [C] = 1$ or there are two such curves C and C' such that $[C] \bullet [C'] = 1$ (here we use that the boundary of the union of the 0-handle with the disjoint 1-handles must be connected). In any case $\dim \eta_1(M) > 0$. The other implications of item (0) are evident.

Let us show now that that **U** and **H** can be realized. $\mathbf{P}^2(\mathbb{R})$ can be obtained by gluing a 2-disk along the boundary of a Möbius band. By Van Kampen theorem we realize that $\pi_1(\mathbf{P}^2(\mathbb{R})) \sim \mathbb{Z}/2\mathbb{Z}$ and is generated by the core C of the Möbius band. Another way to check this fact is by means of the orientation covering $S^2 \rightarrow \mathbf{P}^2(\mathbb{R})$. Then also $\eta_1(\mathbf{P}^2(\mathbb{R})) \sim \mathbb{Z}/2\mathbb{Z}$, generated by $[C]$ and $[C] \bullet [C] = 1$. The above Möbius band can be realized by attaching one 1-handle to an initial 0-handle, and we get $\mathbf{P}^2(\mathbb{R})$ by adding one final 2-handle; this provides a reduced ordered handle decomposition with $\kappa(\mathbf{P}^2(\mathbb{R})) = 1$ 1-handle. By the way we realize also that if $\kappa(M) = 1$ then M is diffeomorphic to $\mathbf{P}^2(\mathbb{R})$.

The fundamental group $\pi_1(S^1 \times S^1) \sim \mathbb{Z} \oplus \mathbb{Z}$ generated by the simple loops $C_1 = S^1 \times \{b_0\}$, $C_2 = \{a_0\} \times S^1$ with base point (a_0, b_0) . It is immediate that $[C_1] \bullet [C_2] = 1$ in $\eta_1(S^1 \times S^1)$, while $[C_j] \bullet [C_j] = 0$, $j = 1, 2$. Hence $[C_1]$ and $[C_2]$ are non zero and linearly independent, $\dim \eta_1(S^1 \times S^1) = 2$ and the intersection form realizes **H**. The union B of a tubular neighbourhood U_1 of C_1 with a tubular neighbourhood U_2 of C_2 can be realized by attaching two disjoint 1-handles to one initial 0-handle, and we get $S^1 \times S^1$ by adding one final 2-handle; this provides a reduced ordered handle decomposition with $\kappa(S^1 \times S^1) = 2$ 1-handles.

Now items (1) and (2) of Theorem 15.10 follow from Lemma 15.7. Note that every $n\mathbf{P}^2(\mathbb{R})$ is not orientable (because it contains a connected curve C such that $[C] \bullet [C] = 1$) while every $n(S^1 \times S^1)$ is orientable, and that all items of Corollary 15.11 hold at least if we limit to consider surfaces M, M' belonging to the families of $n\mathbf{P}^2(\mathbb{R})$'s or $n(S^1 \times S^1)$'s.

It remains to prove item (3) of Theorem 15.10. This is the main point. Thanks to the above characterization of the 2-sphere, we can assume that $\dim \eta_1(M) > 0$. We will follow the proof of the algebraic classification Theorem 15.8, pointing out step by step a topological counterpart. We have already obtained the counterpart of $n\mathbf{U}$ and $n\mathbf{H}$. Assume first that $(\eta_1(M), \bullet_M)$ is totally isotropic. Then every connected smooth simple curve $C \subset M$ has a product tubular neighbourhood, that is equivalently $[C] \bullet_M [C] = 0$. Take such a curve C such that $[C] \neq 0$. By the proof of Lemma 15.3, there is another connected curve $C' \subset M$ which intersects transversely C at one point (so that $[C] \bullet [C'] = 1$, also $[C'] \neq 0$ while $[C'] \bullet_M [C'] = 0$). We check straightforwardly that the union \tilde{B} of a tubular neighbourhood U of C with a tubular neighbourhoods U' of C' is diffeomorphic to the union B of tubular neighbourhoods of the geometric generators of $\pi_1(S^1 \times S^1)$ considered above. Hence the boundary of \tilde{B} is a connected dividing curve in M and this gives rise to a connected sum decomposition

$$M \sim (S^1 \times S^1) \# M'$$

and we know that

$$\kappa(M') = \kappa(M) - 2 .$$

Again by Lemma 15.7, $(\eta_1(M'), \bullet_{M'})$ is also totally isotropic. Then we can conclude by induction on the dimension that in the totally isotropic case

$$M \sim n(S^1 \times S^1), \quad 2n = \kappa(M) = 2 - \chi(M) .$$

Assume now that there is $\alpha \in \eta_1(M)$ such that $\alpha \bullet_M \alpha = 1$. Let $C \subset M$ be a connected simple smooth representative of α . Then a tubular neighbourhood U of C is a Möbius band, its boundary is a dividing curve, we have a connected sum decomposition

$$M \sim \mathbf{P}^2(\mathbb{R}) \# M'$$

and we know that

$$\kappa(M') = \kappa(M) - 1 .$$

By iterating the argument either we get

$$M \sim \kappa(M) \mathbf{P}^2(\mathbb{R})$$

and we have done, or

$$M \sim k \mathbf{P}^2(\mathbb{R}) \# M'$$

for some $k \geq 1$, where $\dim \eta_1(M') > 0$ and $\bullet_{M'}$ is totally isotropic. By applying the above result in this case we eventually get

$$M \sim k \mathbf{P}^2(\mathbb{R}) \# h(S^1 \times S^1) \\ \kappa(M) = k + 2h$$

for some $k, h \geq 1$. We conclude by applying the following final Lemma. Note by the way that it shows also that $\#$ does not verify the ‘cancellation property’.

LEMMA 15.12. $\mathbf{P}^2(\mathbb{R}) \# (S^1 \times S^1) \sim 3 \mathbf{P}^2(\mathbb{R})$.

Proof : First we outline a bare hands proof. After we will outline another (but actually equivalent) based on a transparent geometric construction by using the blowing up of Section 7.10.1.

First proof. Consider $S^1 \times S^1$ with the geometric generators C_1 and C_2 of $\pi_1(S^1 \times S^1)$ transversely intersecting at the base point (a_0, b_0) as above. Remove a open 2-disk D centred at (a_0, b_0) and glue a Möbius band \mathcal{M} along the boundary to get $(S^1 \times S^1) \# \mathbf{P}^2(\mathbb{R})$. Then $(C_1 \cup C_2) \setminus D$ can be completed by means of two fibres of the natural fibration of \mathcal{M} over its core and get two disjoint simple curves \tilde{C}_1 and \tilde{C}_2 in $(S^1 \times S^1) \# \mathbf{P}^2(\mathbb{R})$ which intersect the core of \mathcal{M} transversely at one point respectively. One checks that these curves have disjoint Möbius band tubular neighbourhoods U_1 and U_2 respectively which can be filled to give two copies of $\mathbf{P}^2(\mathbb{R})$; moreover, $(S^1 \times S^1) \# \mathbf{P}^2(\mathbb{R}) \setminus (U_1 \cup U_2)$ is connected. By filling each boundary component with a 2-disk we get a connected boundaryless surface Z such that

$$(S^1 \times S^1) \# \mathbf{P}^2(\mathbb{R}) \sim \mathbf{P}^2(\mathbb{R}) \# Z \# \mathbf{P}^2(\mathbb{R})$$

and $\kappa(Z) = 1$ so that eventually $Z \sim \mathbf{P}^2(\mathbb{R})$.

Second proof. Consider the product $\mathbf{P}^1(\mathbb{R}) \times \mathbf{P}^1(\mathbb{R}) \sim S^1 \times S^1$, endowed with a couple of homogeneous coordinates $(t, s) = ((t_1, t_2), (s_1, s_2))$. Let $\mathbf{P}^3(\mathbb{R})$ with homogeneous coordinates $x = (x_1, x_2, x_3, x_4)$. Define

$$\psi : \mathbf{P}^1(\mathbb{R}) \times \mathbf{P}^1(\mathbb{R}) \rightarrow \mathbf{P}^3(\mathbb{R}) \\ \psi(t, s) = (t_1 s_1, t_1 s_2, t_2 s_1, t_2 s_2) .$$

One verifies that ψ is a well defined smooth embedding onto the quadric $Q \subset \mathbf{P}^3(\mathbb{R})$ defined by the homogeneous equation $x_1 x_4 = x_2 x_3$. Let $p_0 = (1, 0, 0, 0) \in Q$ and consider the “stereographic projection”

$$\phi : V \setminus \{p_0\} \rightarrow P$$

where $P \sim \mathbf{P}^2(\mathbb{R})$ is the projective plane $P \subset \mathbf{P}^3(\mathbb{R})$ defined by the equation $x_1 = 0$. Denote by T the plane tangent to Q at p_0 . It is defined by the equations $x_4 = 0$.

The intersection $T \cap Q$ consists of the union of the two lines passing through p_0 , $l_1 = \{x_4 = x_2 = 0\}$ and $l_2 = \{x_4 = x_3 = 0\}$. $T \cap P$ is the line $l_0 = \{x_1 = x_4 = 0\}$. One verifies that the restriction of ϕ is a diffeomorphism

$$\phi : Q \setminus (l_1 \cup l_2) \rightarrow P \setminus l_0 .$$

Let us blow up $\mathbf{P}^3(\mathbb{R})$ at the point p_0 and take the strict transform \tilde{Q} . We know from the results of Section 7.10.1 that $\tilde{Q} \sim (S^1 \times S^1) \# \mathbf{P}^2(\mathbb{R})$. Blow up $\mathbf{P}^3(\mathbb{R})$ at the two points $p_1 = l_1 \cap P = (0, 1, 0, 0)$ and $p_2 = l_2 \cap P = (0, 0, 1, 0)$. Take the strict transform $\tilde{P} \sim 3\mathbf{P}^2(\mathbb{R})$. Finally one verifies that ϕ extends to a diffeomorphism

$$\tilde{\phi} : \tilde{Q} \rightarrow \tilde{P} .$$

□

Also the proof of Theorem 15.10 and of Corollary 15.11 is now complete.

□

The above classification extends to *compact connected surfaces with boundary*. We limit to a few indications. Details are left to the reader.

- Let M be a compact connected smooth surface with $r \geq 1$ boundary components. Denote by \hat{M} the boundaryless surface obtained by filling every boundary component with a 2-disk. *Viceversa* M is obtained from \hat{M} by removing the interior of r disjoint closed 2-disks. By the uniqueness of the disks up to isotopy, M is determined up to diffeomorphism by r and the diffeomorphism type of \hat{M} .

- The radical $\text{Rad}(\bullet_M) \subset \eta_1(M)$ of the intersection form \bullet_M is of dimension $r - 1$ and is generated by the boundary components of M . The non degenerate form $\hat{\bullet}_M$ uniquely induced up to isometry by \bullet_M on $\eta_1(M)/\text{Rad}(\bullet_M)$ is isometric to $\bullet_{\hat{M}}$. Hence M is determined up to diffeomorphism by the isometry class of the intersection form \bullet_M , that is by $\dim \text{Rad}(\bullet_M)$ and the isometry class of $\bullet_{\hat{M}}$.

- Two compact connected smooth surfaces with boundary M and M' are diffeomorphic if and only if they have the same number of boundary components, $\chi(M) = \chi(M')$, and either they are both orientable or non orientable.

15.3. $\Omega_1(X)$ as the abelianization of the fundamental group

Recall that in Proposition 10.12 we have established a natural epimorphism

$$h_1 : \pi_1(X, x_0) \rightarrow \Omega_1(X)$$

X being a path-connected topological space. Now we are able to determine the kernel of this epimorphism.

PROPOSITION 15.13. *The kernel $\ker h_1$ coincides with the commutator subgroup of $\pi_1(X, x_0)$, hence $\Omega_1(X)$ is the abelianization of the fundamental group.*

Proof : Let $\gamma : (S^1, p) \rightarrow (X, x_0)$ be a homotopically non trivial loop which represents $0 \in \Omega_1(X)$. Then γ can be extended to a map $h : \Sigma \rightarrow X$ where Σ is a compact orientable surface with boundary $\partial\Sigma = S^1$ such that by attaching a 2-disk along $\partial\Sigma$, we get a boundaryless compact orientable surface $\tilde{\Sigma}$ of genus say $g \geq 1$. By using the concrete models for such a surface provided by the classification theorem, we see that there is embedded in $\tilde{\Sigma}$ a wedge of $2g$ -simple loops based at p , not intersecting $D^2 \setminus \{p\}$, such that by cutting the surface along these loops we get a $4g$ -gone and γ retracts onto that wedge within Σ . Finally one realizes that these loops can be distribute in two family say $a_1, \dots, a_g, b_1, \dots, b_g$, in such a way that the above retraction realizes a homotopy between γ and the composite loop

$$a_1 b_1 a_1^{-1} b_1^{-1} a_2 b_2 a_2^{-1} b_2^{-1} \dots a_g b_g a_g^{-1} b_g^{-1} .$$

The proposition follows.

□

The above proposition means that every homomorphism $\phi : \pi_1(X, x_0) \rightarrow G$ where G is abelian factorizes as $\phi = \hat{\phi} \circ h_1$, $\hat{\phi} : \Omega_1(X) \rightarrow G$.

15.4. Ω_2 and η_2

Here we consider again boundaryless compact surfaces. As a corollary of the classification we have

THEOREM 15.14. (1) $\Omega_2 = 0$;

(2) $\eta_2 \sim \mathbb{Z}/2\mathbb{Z}$ and is generated by $[\mathbf{P}^2(\mathbb{R})]$.

(3) $\psi : \eta_2 \rightarrow \mathbb{Z}/2\mathbb{Z}$, $\phi([M]) := \chi_{(2)}(M)$ is a well defined isomorphism.

Proof : Recall that

$$[M_1 \# M_2] = [M_1] + [M_2] \in \eta_2$$

(resp. $\in \Omega_2$ in the oriented setting). It follows from the classification that every compact connected oriented surface is the boundary of an oriented 3-manifold (in fact $n(S^1 \times S^1)$ can be embedded in $S^3 = \mathbb{R}^3 \cup \infty$ and divides it). Hence $\Omega_2 = 0$.

On the other hand for every compact connected surface M ,

$$[M \# 2\mathbf{P}^2(\mathbb{R})] = [M] \in \eta_2$$

and

$$M \# 2\mathbf{P}^2(\mathbb{R}) \sim (\kappa(M) + 2)\mathbf{P}^2(\mathbb{R})$$

by the classification. Hence

$$[M] = \chi_{(2)}(M)[\mathbf{P}^2(\mathbb{R})] \in \eta_2 .$$

As $[\mathbf{P}^2(\mathbb{R})] \neq 0$ then items (2) and (3) follow. □

15.4.1. η_2 as a Witt group. Apparently Theorem 15.14 is exhaustive. However the topological classification of surfaces runs parallel to the algebraic classification on $\mathbb{Z}/2\mathbb{Z}$ -symmetric bilinear forms up to isometry. We would like to recast also the content of Theorem 15.14 within this vein.

Denote by $I(\mathbb{Z}/2\mathbb{Z})$ the set of isometry classes of non degenerate symmetric bilinear forms defined on $\mathbb{Z}/2\mathbb{Z}$ -vector spaces of arbitrary finite dimension. $I(\mathbb{Z}/2\mathbb{Z})$ is a semigroup provided it is endowed with the operation \perp . $S \in I(\mathbb{Z}/2\mathbb{Z})$ is said *neutral* if $\dim S = 2m$ is even and there is a subspace $Z \subset S$, $\dim Z = m$ such that $Z = Z^\perp$. It follows from Theorem 15.8 that S is neutral if and only if either $S = 2m\mathbf{U}$ or $S = m\mathbf{H}$, for some m . Put on $I(\mathbb{Z}/2\mathbb{Z})$ the equivalence relation $X \sim X'$ if and only if there are neutral spaces S, S' such that

$$X \perp S = X' \perp S' .$$

Denote by $W(\mathbb{Z}/2\mathbb{Z})$ the quotient set. For every $X \in I(\mathbb{Z}/2\mathbb{Z})$, $X \perp X$ is neutral, hence \perp descends to $W(\mathbb{Z}/2\mathbb{Z})$ and makes it an abelian group called the *Witt group* of the field $\mathbb{Z}/2\mathbb{Z}$; $0 \in W(\mathbb{Z}/2\mathbb{Z})$ is the class of neutral spaces, and for every $[X] \in W(\mathbb{Z}/2\mathbb{Z})$, $-[X] = [X]$. It follows from Theorem 15.8 that

$$r_{(2)} : W(\mathbb{Z}/2\mathbb{Z}) \rightarrow \mathbb{Z}/2\mathbb{Z}, \quad r_{(2)}([X]) := \dim X \bmod 2$$

is a well defined isomorphism of groups. Finally the content of Theorem 15.14 can be rephrased as follows

THEOREM 15.15.

$$\mathfrak{w} : \eta_2 \rightarrow W(\mathbb{Z}/2\mathbb{Z}), \quad \mathfrak{w}([M]) = [\bullet M]$$

is a well defined isomorphism; moreover

$$r_{(2)} \circ \mathfrak{w} = \chi_{(2)} .$$

□

15.4.2. A direct derivation of Ω_2 and η_2 . Theorem 15.14 has been derived as a corollary of the classification. Here we outline a direct derivation; the mechanism is interesting: starting from a 2-dimensional handle decomposition of M it produces a 3-dimensional handle decomposition in such a way that the surface is the boundary; somehow M *builds its 'simplest bulk'*.

For every compact connected M as usual, take a reduced ordered handle decomposition with $\kappa = \kappa(M)$ 1-handles. Hence starting from $(M_0, \partial M_0) = (D^2, S^1)$, we have a sequence $(M_i, \partial M_i)$, $i = 1, \dots, \kappa$, obtained by attaching one 1-handle to $(M_{i-1}, \partial M_{i-1})$; finally M is obtained by attaching a 2-handle to $(M_\kappa, \partial M_\kappa)$. Consider the product 3-manifold $W = M \times [0, 1]$. On the copy $M' = M \times \{1\}$ of M , consider the family of pairwise disjoint non necessarily connected curves ∂M_i , $i = 0, \dots, \kappa$. There is a system of pairwise disjoint tubular neighbourhoods $U_i \sim \partial M_i \times [-1, 1]$ of these curves in M' . Let us attach to W along M' a family of κ disjoint three dimensional 2-handles, each one attached along U_i , $i = 0, \dots, \kappa$. In this way we get a 3-manifold W' such that

$$\partial W' = (M \times \{0\}) \amalg M''$$

where M'' has $\kappa+2$ connected components, each one associated to one of the handles of the original decomposition of M . It is not hard to see that a component of M'' corresponding either to the 0-handle or the 2-handle of M is diffeomorphic to S^2 . For a component associated to a 1-handle there are two possibilities:

- (1) Starting from an annulus $A \sim S^1 \times [0, 1]$ we attach the 1-handle along $S^1 \times \{1\}$ in such a way that the resulting surface is orientable; then this surface is a 'pant' P and the corresponding component of M'' is obtained by filling every component of ∂P with a 2-disk, so that it is diffeomorphic to S^2 .
- (2) Starting from an annulus $A \sim S^1 \times [0, 1]$ we attach the 1-handle along $S^1 \times \{1\}$ in such a way that the resulting surface is non orientable; then this surface is a Möbius band \mathcal{M} and the corresponding component of M'' is obtained by filling $\partial \mathcal{M}$ with a 2-disk, so that it is diffeomorphic to $\mathbf{P}^2(\mathbb{R})$.

It follows that M is bordant with the disjoint union of k copies of $\mathbf{P}^2(\mathbb{R})$ for some $k \geq 0$. This is enough to conclude that $\eta_2 \sim \mathbb{Z}/2\mathbb{Z}$ and is generated by $[\mathbf{P}^2(\mathbb{R})]$.

Assume now that M is orientable. Hence W is orientable, and also W' is orientable because attaching a 2-handle does not destroy the orientability. Also $\partial W'$ is orientable so that M'' is a disjoint union of 2-spheres. This is enough to conclude that $\Omega_2 = 0$. But we can say more. Let W'' be obtained from W' by filling every component of M'' with a 3-disk. By construction, W'' is obtained from W by attaching a few disjoint 2-handles followed by a few 3-handles. By considering the dual decomposition, we see that W is obtained starting from a few 0-handles followed by a few disjoint 1-handles. By cancellation of 0-handles we can assume that there is only one 0-handle. By sliding handles, we realize that up to diffeomorphism $W'' := \mathcal{H}_h$ is uniquely determined by the number h of 1-handles, it is called a *handlebody of genus h* , and $M = \partial \mathcal{H}_h$. By some consideration about the Euler-Poincaré characteristic, one finally realizes that $\kappa(M) = 2h$; in this way we have re-obtained a classification up to diffeomorphism, at least in the orientable case.

15.5. Stable equivalence - Rational models (2D Nash's conjecture)

The classification of surfaces up to diffeomorphism contains a coarse classification up to *stabilization*: let us say that two (compact connected boundaryless, as

usual) surfaces M and M' are *stably equivalent* if there are $n, m \in \mathbb{N}$ such that

$$M \# n\mathbf{P}^2(\mathbb{R}) \sim M' \# m\mathbf{P}^2(\mathbb{R}) .$$

Then we have as an immediate corollary of the full classification that *every surface is stably equivalent to each other*. In the orientable setting we have a similar result up to stabilization by some $n(S^1 \times S^1)$.

This coarse classification deserves to be pointed out because it is a sort of toy model of phenomena occurring for example in dimension 4 (in spite of the fact that a full classification is not known in such a case), and also because it has a different flavour once we interpret $\#\mathbf{P}^2(\mathbb{R})$ as the *blowing up at a point*, accordingly to Section 7.10.1. Then a stable equivalence between M and M' is realized by a \tilde{M} which dominates both being obtained by blowing up some points of each respectively; equivalently we can say that M' is obtained from M by firstly blowing up some points of M and then performing a certain *blowing down* to M' .

Recall (Remark 7.30) that a compact real algebraic set X is *rational* if it *birationally equivalent* to the projective space of the same dimension, say $\mathbf{P}^n(\mathbb{R})$; that is X contains a non empty Zariski open set which is algebraically isomorphic to a Zariski open set in the projective space of the same dimension. If $X = B(\mathbf{P}^n(\mathbb{R}), Y)$ is obtained from $\mathbf{P}^n(\mathbb{R})$ by some blowing up along a regular algebraic centre (in particular a finite set of points), then X is a rational regular algebraic set. A so called “Nash’s conjecture” stated in [Na] asked if every compact smooth manifold admits up to diffeomorphism any rational regular real algebraic model. We have a rather complete answer in the case of surfaces:

- Every non orientable surface $M \sim \mathbf{P}^2(\mathbb{R}) \# n\mathbf{P}^2(\mathbb{R}) \sim B(\mathbf{P}^2(\mathbb{R}), Y)$, $\kappa(M) = n + 1$, Y consisting of n points, has a rational model;

- If M is orientable $M \# \mathbf{P}^2(\mathbb{R})$ admits a rational model $B(\mathbf{P}^2(\mathbb{R}), Y)$ where Y consists of $2n = \kappa(M)$ points. One can ask if Y as above can be chosen in such a way that a blowing down that returns M can be done in the algebraic setting, providing a rational model for M itself. For example in the second proof of Lemma 15.12, we see such a mechanism which produces $\mathbf{P}^1(\mathbb{R}) \times \mathbf{P}^1(\mathbb{R}) \sim S^1 \times S^1$ by blowing down $B(\mathbf{P}^2(\mathbb{R}), \{p_1, p_2\})$, collapsing to a point p_0 the strict transform of the line of $\mathbf{P}^2(\mathbb{R})$ passing through the points p_1 and p_2 . One can prove in general that if $Y = \{p_1, \dots, p_{2n}\}$ is contained in a projective line $l \subset \mathbf{P}^2(\mathbb{R})$, then by blowing down to a point p_0 the strict transform \tilde{l} of l in $B(\mathbf{P}^2(\mathbb{R}), Y)$ we get a rational algebraic set X , which is *homeomorphic* to M via a algebraic homeomorphism which restricts to an algebraic isomorphism between regular Zariski open sets

$$B(\mathbf{P}^2(\mathbb{R}), Y) \setminus \tilde{l} \rightarrow X \setminus \{p_0\} .$$

However, if $n > 1$ X is not regular as it has one isolated singularity at p_0 . These rational models with one isolated singularity are the best we can do because it is known since Comessati [COM] that $S^1 \times S^1$ is the only *orientable* surface admitting a *regular* rational model.

15.6. Quadratic enhancement of surface intersection forms

Let $(\eta_1(M), \bullet_M)$ be as above, where M is a compact connected boundaryless surface. In several situations one is interested to the embeddings or immersions of M in a given higher dimensional manifold, considered up to suitable equivalence relations which often enhance the abstract surface bordism. In such situations so called *quadratic enhancements* of the intersection form naturally arise. In this section we will develop a few aspects of the abstract theory of such structures. Many proofs are simple exercises and we will omit them. Later in the text we will see concrete applications (see Sections 17.4.3, 19.8.1, 19.9, 20.6).

Let (V, β) be a finite dimensional $\mathbb{Z}/2\mathbb{Z}$ -vector space endowed with a non degenerate symmetric bilinear form β .

(*Totally isotropic case*) Assume first that β is totally isotropic, so that (V, β) is isometric to $g\mathbf{H}$, $\dim V = 2g$.

DEFINITION 15.16. a map $q : V \rightarrow \mathbb{Z}/2\mathbb{Z}$ is a *quadratic enhancement* of (V, β) (sometimes we simply say “of β ”) if for every $x, y \in V$,

$$q(x + y) = q(x) + q(y) + \beta(x, y) .$$

We can enhance the equivalence relation “up to isometry” to the set of such triples:

$$f : (V_1, \beta_1, q_1) \rightarrow (V_2, \beta_2, q_2)$$

is an *isometry* if and only if

$$f : (V_1, \beta_1) \rightarrow (V_2, \beta_2)$$

is an isometry in the usual sense and moreover, for every $x \in V_1$, $q_1(x) = q_2(f(x))$. We denote by

$$I_q^{\mathbf{H}}(\mathbb{Z}/2\mathbb{Z})$$

the set of isometry classes of these triples. The operation “ \perp ” gives it a semigroup structure.

It is rather easy to enhance the results of Section 15.1 (in the totally isotropic case); as usual sometimes we will confuse representatives with their isometry classes:

- Up to isometry there are exactly two quadratic enhancement of \mathbf{H} (endowed with the standard hyperbolic basis say $\{e_0, e_1\}$):

- $q_0(e_0) = q_0(e_1) = 0$, $q_0(e_0 + e_1) = 1$; denote by $\mathbf{H}^{0,0}$ the corresponding equipped space;
- $q_1(e_0) = q_1(e_1) = q_1(e_0 + e_1) = 1$; denote by $\mathbf{H}^{1,1}$ the corresponding equipped space.

Then every triple (V, β, q) is isometric to

$$m\mathbf{H}^{0,0} \perp n\mathbf{H}^{1,1}$$

for some $m, n \in \mathbb{N}$ such that $2(m + n) = 2g = \dim V$. Such integers m and n are not unique; in fact we have

$$\text{LEMMA 15.17. } \mathbf{H}^{0,0} \perp \mathbf{H}^{0,0} = \mathbf{H}^{1,1} \perp \mathbf{H}^{1,1} .$$

□

PROPOSITION 15.18. (1)

$$\text{Arf} : (I_q^{\mathbf{H}}(\mathbb{Z}/2\mathbb{Z}), \perp) \rightarrow (\mathbb{Z}/2\mathbb{Z}, +), \text{ Arf}([V, \beta, q]) = n \pmod{2}$$

provided that $[V, \beta, q] = m\mathbf{H}^{0,0} \perp n\mathbf{H}^{1,1}$ for some $(m, n) \in \mathbb{N}^2$, is a well defined surjective semigroup homomorphism.

(2) $\text{Arf}([V, \beta, q]) = 1$ if and only if $|q^{-1}(1)| > |q^{-1}(0)|$; $\text{Arf}([V, \beta, q]) = 0$ if and only if $|q^{-1}(1)| < |q^{-1}(0)|$.

(3) If $[V, \beta] = g\mathbf{H}$ and the j -copy of \mathbf{H} is endowed with its standard hyperbolic basis $\{e_0^j, e_1^j\}$, $j = 1, \dots, g$, then

$$\text{Arf}([V, \beta, q]) = \sum_j q(e_0^j)q(e_1^j) .$$

□

Arf is called the *Arf invariant*.

We can define the *Witt group* associated to the semigroup

$$(I_q^{\mathbf{H}}(\mathbb{Z}/2\mathbb{Z}), \perp) .$$

$[V, \beta, q] \in I_q^{\mathbf{H}}(\mathbb{Z}/2\mathbb{Z})$, $\dim V = 2g$, is said *neutral* if there is a subspace $Z \subset V$, such that $\dim Z = g$, $Z = Z^\perp$ and q vanishes on Z . Put on $I_q^{\mathbf{H}}(\mathbb{Z}/2\mathbb{Z})$ the equivalence relation $X \sim X'$ if and only if there are neutral spaces S, S' such that

$$X \perp S = X' \perp S' .$$

Denote by $W_q^{\mathbf{H}}(\mathbb{Z}/2\mathbb{Z})$ the quotient set. The operation \perp descends to $W_q^{\mathbf{H}}(\mathbb{Z}/2\mathbb{Z})$ and makes it an abelian group. We have:

PROPOSITION 15.19. *The Arf homomorphism passes to the quotient*

$$\text{Arf} : W_q^{\mathbf{H}}(\mathbb{Z}/2\mathbb{Z}) \rightarrow \mathbb{Z}/2\mathbb{Z}$$

and is in fact a group isomorphism. The Witt group is generated by $\mathbf{H}^{1,1}$.

□

We know that $(I^{\mathbf{H}}(\mathbb{Z}/2\mathbb{Z}), \perp)$ is isomorphic to the semigroup of *orientable* compact connected boundaryless surfaces (considered up to diffeomorphism) endowed with the “#” operation. The isomorphism is given by associating to every surface M the class of $(\eta_1(M), \bullet_M)$. So the above algebraic discussion can be rephrased in such a more topological setting. In particular the bases evoked in item (3) of Proposition 15.18 can be realized geometrically: if M is a surface of genus g then we can find two families of g smooth circles $\{A_1, \dots, A_g\}$ and $\{B_1, \dots, B_g\}$ such that

- $A_i \cap A_j = B_i \cap B_j = \emptyset$ if $i \neq j$,
- A_i and B_j intersect transversely at one point if and only if $i = j$, otherwise $A_i \cap B_j = \emptyset$.

Then these $2g$ circles form a basis of $\eta_1(M)$; if q is a quadratic enhancement of \bullet_M , then

$$\text{Arf}(q) = \sum_j q([A_j])q([B_j]) .$$

$W_q^{\mathbf{H}}(\mathbb{Z}/2\mathbb{Z})$ can be considered as a formal non trivial refinement of $\Omega_2 = 0$.

(General case) Now we consider arbitrary non degenerate spaces (V, β) . In this generality the notion of quadratic enhancement is subtler, due to the presence of non isotropic elements. The key point is to consider $\mathbb{Z}/4\mathbb{Z}$ instead of $\mathbb{Z}/2\mathbb{Z}$ -valued forms q .

DEFINITION 15.20. A map

$$q : V \rightarrow \mathbb{Z}/4\mathbb{Z}$$

is a quadratic enhancement of β if for every $x, y \in V$,

$$q(x + y) = q(x) + q(y) + 2\beta(x, y)$$

where $a \rightarrow 2a$ is the unique non trivial homomorphism $\mathbb{Z}/2\mathbb{Z} \rightarrow \mathbb{Z}/4\mathbb{Z}$.

REMARK 15.21. Assume that (V, β) is totally isotropic. If $\bar{q} : V \rightarrow \mathbb{Z}/2\mathbb{Z}$ is a quadratic enhancement of β in the early sense, then $q = 2\bar{q}$ is a quadratic enhancement in the new sense. On the other hand, if $q : V \rightarrow \mathbb{Z}/4\mathbb{Z}$ is as in Definition 15.20, then it takes only even values and there is a unique $\bar{q} : V \rightarrow \mathbb{Z}/2\mathbb{Z}$ such that $q = 2\bar{q}$. So if we restrict to totally isotropic spaces we recover the previous setting.

The set of quadratic enhancement of (V, β) has a structure of *affine space over* V . That is we have

LEMMA 15.22. *There are $2^{\dim V} \bmod (4)$ quadratic enhancements of (V, β) ; if q is one the others are of the form*

$$q'(x) = q(x) + 2\beta(u, x)$$

for a unique $u \in V$.

Proof: $l(x) := 2^{-1}(q'(x) - q(x))$ is linear hence represented by a unique $u \in V$ by means of the non degenerate form β . □

The notion of isometry of triples extends *verbatim* and we denote by

$$(I_q(\mathbb{Z}/2\mathbb{Z}, \mathbb{Z}/4\mathbb{Z}), \perp)$$

the semigroup of isometry classes. We have

- Up to isometry on \mathbf{H} there are two $\mathbb{Z}/4\mathbb{Z}$ -valued quadratic enhancements, that is $q_j = 2q_j$, $j = 0, 1$, where $q_j : \mathbf{H} \rightarrow \mathbb{Z}/2\mathbb{Z}$ have been already defined above. We keep the notations $\mathbf{H}^{j,j}$ for the associated equipped spaces.

- Up to isometry, on \mathbf{U} there are two quadratic enhancement $q^\pm : \mathbf{U} \rightarrow \mathbb{Z}/4\mathbb{Z}$, $q^\pm(1) = \pm 1$. Denote by \mathbf{U}^\pm the corresponding equipped spaces.

Hence for every (V, β) totally isotropic we still have

$$[V, \beta, q] = m\mathbf{H}^{0,0} \perp n\mathbf{H}^{1,1}, \quad 2(m+n) = \dim V ;$$

If (V, β) is not totally isotropic, then

$$[V, \beta, q] = a\mathbf{U}^- \perp b\mathbf{U}^+$$

for some $(a, b) \in \mathbb{N}^2$, $a + b = \dim V$. As above we are not claiming that (a, b) is unique.

In any case we say that $[V, \beta, q]$ is *neutral* if there exists a subspace $Z \subset V$ such that $Z = Z^\perp$ (so that $\dim V = 2h$ is even and $\dim Z = h$) and q vanishes on Z . As above we can define the *Witt group* denoted by

$$W_q(\mathbb{Z}/2\mathbb{Z}, \mathbb{Z}/4\mathbb{Z})$$

as a quotient of the semigroup $(I_q(\mathbb{Z}/2\mathbb{Z}, \mathbb{Z}/4\mathbb{Z}), \perp)$.

For every $[V, \beta, q] \in I_q(\mathbb{Z}/2\mathbb{Z}, \mathbb{Z}/4\mathbb{Z})$, for every $x \in V$, define

$$\psi_{[V, \beta, q]}(x) := \exp\left(\frac{i\pi}{2}q(x)\right) = i^{q(x)} .$$

Finally set

$$\gamma([V, \beta, q]) := \left(\frac{1}{\sqrt{2}}\right)^{\dim V} \sum_{x \in V} \psi_{[V, \beta, q]}(x) .$$

This is called the multiplicative *Brown invariant* of $[V, \beta, q]$.

For every $k \geq 2$, denote by U_k the multiplicative subgroup of $U(1)$ formed by the k th-roots of 1. Denote by

$$\alpha_k : (\mathbb{Z}/k\mathbb{Z}, +) \rightarrow U_k$$

the natural isomorphism of groups.

LEMMA 15.23. *If (V, β) is totally isotropic so that $q = 2\bar{q}$ for a unique*

$$\bar{q} : V \rightarrow \mathbb{Z}/2\mathbb{Z}$$

then

$$\gamma([V, \beta, q]) = \alpha_2(\text{Arf}([V, \beta, \bar{q}])) .$$

□

Hence the Brown invariant extends the Arf one.

For every $X = [V, \beta, q]$, set $-X := [V, \beta, -q]$. We have

LEMMA 15.24. *Let $X, Y \in I_q(\mathbb{Z}/2\mathbb{Z}, \mathbb{Z}/4\mathbb{Z})$. Then:*

- (1) $\gamma(X \perp Y) = \gamma(X)\gamma(Y)$;
- (2) *If X is neutral, then $\gamma(X) = 1$;*
- (3) $4X = 4(-X)$.

Proof : (1) follows from the very definition.

As for (2), let $X = [V, \beta, q]$, $Z \subset V$, $\dim V = 2n$, $\dim Z = n$, $Z = Z^\perp$, q vanishing on Z . For simplicity we omit the index X in denoting ψ . Let $V = Z \oplus L$ be any direct sum decomposition. Then

$$\begin{aligned} \gamma(q) &= \left(\frac{1}{\sqrt{2}}\right)^{2n} \sum_{z \in Z, l \in L} \psi(z+l) = \left(\frac{1}{\sqrt{2}}\right)^{2n} \sum_{z \in Z, l \in L} \psi(l)(-1)^{\beta(l,z)} = \\ &= \left(\frac{1}{\sqrt{2}}\right)^{2n} \left[\sum_{l \in L \setminus \{0\}} \left(\sum_{z \in Z} (-1)^{\beta(l,z)} \psi(l) \right) + |Z| \right] = \\ &= \left(\frac{1}{\sqrt{2}}\right)^{2n} |Z| = 1 \end{aligned}$$

where the fourth equality depends on the fact that for every $l \neq 0$, $z \rightarrow \beta(l, z)$ defines a linear form ϕ on Z , and $\dim \ker(\phi) = \dim Z - 1$ as β is non degenerate.

As for (3), it is enough to show that $4\mathbf{U}^+ = 4\mathbf{U}^-$. Let $\{e_1, e_2, e_3, e_4\}$ be the standard basis of $4\mathbb{C} \sim \mathbb{C}^4$. Let $\rho_j : \mathbb{C} \rightarrow \mathbb{C}^4$ be the linear embedding such that $\rho_j(1) = e_j$. Then one verifies that the linear isomorphism

$$\rho = (\rho_1, \dots, \rho_4) : \mathbb{C}^4 \rightarrow \mathbb{C}^4$$

induces a required isomorphism

$$\rho : 4\mathbf{U}^+ \rightarrow 4\mathbf{U}^- .$$

□

Finally we can state the main result of this matter.

THEOREM 15.25. *The Brown semigroup morphism γ passes to the quotient and in fact it determines a group isomorphism*

$$\tilde{\gamma} := \alpha_8^{-1} \circ \gamma : W_q(\mathbb{Z}/2\mathbb{Z}, \mathbb{Z}/4\mathbb{Z}) \rightarrow \mathbb{Z}/8\mathbb{Z} .$$

The Witt group is generated by \mathbf{U}^+ .

Proof : $\mathbf{U}^+ \perp \mathbf{U}^-$ is neutral, then the Witt group is cyclic generated by \mathbf{U}^+ . By the previous lemma, $8\mathbf{U}^+$ is neutral, hence the order of \mathbf{U}^+ divides 8. Finally by direct computation $\gamma(\mathbf{U}^+) = \exp(\frac{i\pi}{4})$ that is it is a primitive fourth root of 1.

□

The following Corollary is easy.

COROLLARY 15.26. *The Brown invariant of q , the dimension of V and the fact that β is or not totally isotropic form a complete set of invariants which classifies $[V, \beta, q] \in I_q(\mathbb{Z}/2\mathbb{Z}, \mathbb{Z}/4\mathbb{Z})$.*

□

By rephrasing everything in the topological 2-dimensional setting, we can say that the Witt group $W_q(\mathbb{Z}/2\mathbb{Z}, \mathbb{Z}/4\mathbb{Z}) \sim \mathbb{Z}/8\mathbb{Z}$ is a formal enhancement of the Witt group $W(\mathbb{Z}/2\mathbb{Z}) \sim \eta_2 \sim \mathbb{Z}/2\mathbb{Z}$.

We conclude this section by outlining a constructive way to build quadratic enhancements of (M, \bullet_M) for a given compact boundaryless surface M (see [KT], Lemma 3.4). It is enough to define a function q which associates an element in $\mathbb{Z}/4\mathbb{Z}$

to every disjoint union of smooth circles on M (considered up to ambient isotopy) provided that the the following conditions are satisfied:

- (1) The function q is *additive on disjoint unions*: if $L_1 \amalg L_2$ is again a disjoint union of circles, then $q(L_1 \amalg L_2) = q(L_1) + q(L_2)$;
- (2) If K_1 and K_2 are two circles that cross transversely at r points, then by resolving (in one of the two possible ways) each crossing we get a disjoint union L of embedded circles. Then $q(L) = q(K_1) + q(K_2) + 2r \pmod{4}$.
- (3) If K is is a smooth circle that bounds a 2-disk in M , then $q(K) = 0$.

In such a situation, a quadratic enhancement of $(\eta_1(M), \bullet_M)$ is defined by setting $q(\alpha) = q(C)$ where C is any smooth circle representing α .

Bordism characteristic numbers

Let us give a definition of η -characteristic number modeled on the Euler-Poincaré characteristic mod(2), $\chi_{(2)}$. As usual denote by \mathcal{S}_n the class of compact boundaryless smooth n -manifolds. For every $X \in \mathcal{S}_n$, let

$$t_X : X \rightarrow \mathfrak{G}_{m,n}$$

be a “truncated” classifying map of the tangent bundle $T(X)$, where $m = m(n)$ big enough only depends on n . An η -characteristic number is a function

$$\mathfrak{c} : \mathcal{S}_n \rightarrow \mathbb{Z}/2\mathbb{Z}$$

such that

- (1) It is of the form

$$\mathfrak{c}(X) = \mathfrak{c}_\alpha(X) := \sum_j t_X^*(\alpha) \cap [X_j]$$

for some $\alpha \in \eta^n(\mathfrak{G}_{m,n})$, where X_j varies among the connected components of X . Clearly such a $\mathfrak{c}(X)$ is a diffeomorphism invariant.

- (2) If $[X] = 0 \in \eta_n$, then $\mathfrak{c}(X) = 0$. It follows that \mathfrak{c} induces a $\mathbb{Z}/2\mathbb{Z}$ -linear map

$$\mathfrak{c} : \eta_n \rightarrow \mathbb{Z}/2\mathbb{Z} .$$

Here is another characteristic η -number besides $\chi_{(2)}$. For every X , consider the n th-power (with respect to the \sqcup product)

$$w^1(X)^n$$

of the Euler class of the determinant line bundle of X .

PROPOSITION 16.1. $\mathfrak{c}_{w^1(X)^n}$ is a η -characteristic number, different from $\chi_{(2)}$.

Proof: To see that it is characteristic, it is enough to show that if $X = \partial W$ is a boundary, then $\mathfrak{c}_{w^1(X)^n}(X) = 0$. Note that

$$w^1(X) = j^* w^1(W) \in \eta^1(W, \partial W)$$

where $j : \partial W \rightarrow W$ is the inclusion. Then $w^1(X)^n = (j^*(w^1(W)))^n$, and $w^1(X)^n$ is represented by the boundary of the proper 1-dimensional submanifold of $(W, \partial W)$ which represents $w^1(W)^n \in \eta^n(W, \partial W)$, hence it consists of an even number of points. To see that it is different from $\chi_{(2)}$, consider for example $w^1(\mathbf{P}^4(\mathbb{R}))^4 = 1$ while we can show (do it by exercise) that $w^1(\mathbf{P}^2(\mathbb{R}) \times \mathbf{P}^2(\mathbb{R}))^4 = 0$. We know that both characteristic mod(2) are equal to 1. Hence $[\mathbf{P}^4(\mathbb{R})]$ and $[\mathbf{P}^2(\mathbb{R}) \times \mathbf{P}^2(\mathbb{R})]$ are non trivial independent elements of η_4 . Similarly $w^1(*)^n$ distinguishes $[\mathbf{P}^4(\mathbb{R})]$ from $[\mathbf{P}^2(\mathbb{C})]$. The same argument extends to any couple $\mathbf{P}^{a+b}(\mathbb{R})$, $\mathbf{P}^a(\mathbb{R}) \times \mathbf{P}^b(\mathbb{R})$ (hence to η_{a+b}) where both a and b are even. □

16.1. Stable η -numbers

It is not so easy to check directly if a function of the form \mathbf{c}_α as above is a characteristic number or not (that is if it vanishes on boundaries). On the other hand, this becomes almost immediate if we consider so called “stable classes” in the grassmannian cobordism. Consider the “stabilized tautological bundle”

$$\tau_{m,n} \oplus \epsilon^1 ;$$

this corresponds to an evident classifying map

$$s_n : \mathfrak{G}_{m,n} \rightarrow \mathfrak{G}_{m+1,n+1} .$$

Then $\alpha \in \eta^k(\mathfrak{G}_{m,n})$ (not necessarily $k = n$) is by definition a *stable class* if

$$\alpha = s_n^*(\tilde{\alpha})$$

for some $\tilde{\alpha} \in \eta^k(\mathfrak{G}_{m+1,n+1})$. The sum and the product of stable classes are stable. A class of the form $\alpha = (s_{n+j} \circ \cdots \circ s_n)^*(\tilde{\alpha})$ is stable for every $j \geq 0$.

For every $X \in \mathcal{S}_n$, the classifying map of the *stable tangent bundle*

$$T(X) \oplus \epsilon^1$$

is the composite map

$$s_X := s_n \circ t_X .$$

We have

PROPOSITION 16.2. *For every $n \geq 0$, if $\alpha \in \eta^n(\mathfrak{G}_{m,n})$ is a stable class then \mathbf{c}_α is a (stable by definition) η -characteristic number defined on \mathcal{S}_n .*

Proof : Assume that $X = \partial W$; then

$$j^*(T(W)) = T(X) \oplus \epsilon^1$$

so that $s_X = s_W \circ j$, where j is the inclusion. It follows that

$$t_X^*(\alpha) = j^*(t_W^*(\alpha))$$

hence $t_X^*(\alpha)$ is represented by the boundary of a singular proper 1-submanifold of $(W, \partial W)$ which represents $t_W^*(\alpha)$. □

A construction of stable characteristic classes. In general, if $\alpha \in \eta^k(\mathfrak{G}_{m,n})$ is a stable class, then $t_X^*(\alpha)$ is called a *stable characteristic class* of X . This can be extended by dealing with the classifying map of arbitrary vector bundles ξ on X and leads to the notion of stable characteristic classes of ξ . For simplicity we will assume that X is connected

For every *line bundle* ξ on a X , define the *total basic cobordism class*

$$w(\xi) = \sum_{j=0}^n w^1(\xi)^j \in \eta^\bullet(X)$$

where we stipulate that $w(\xi)^0 := [X]$. If we have the direct sum $\xi = \xi_1 \oplus \xi_2$ of two line bundles set its total cobordism class

$$w(\xi_1 \oplus \xi_2) := w(\xi_1) \sqcup w(\xi_2) \in \eta^\bullet(X)$$

and define $w^j(\xi_1 \oplus \xi_2) \in \eta^j(X)$, $j = 0, \dots, n$, the j th-homogeneous term of $w(\xi_1 \oplus \xi_2)$. This can be inductively extended to every direct sum of line bundles on X , $\xi = \xi_1 \oplus \cdots \oplus \xi_r$, $r \leq \dim X$. As $w(\epsilon^h) = [X]$, we see that all classes defined so far are stable classes of ξ .

REMARK 16.3. The stable classes defined sofar might depend *a priori* on the given splitting of ξ as direct sum of line bundles. It is a non trivial fact that they do not. This is part of the construction of the so called *Stiefel Whitney classes* of vector bundles (see [MS]) which we will not develop.

For every $\mathbf{P}^a(\mathbb{R})$, for every $n > 0$, denote by β the bundle of rank n on $\prod_{j=1}^n \mathbf{P}^a(\mathbb{R})$ given by the product of n copies of the tautological line bundle over $\mathbf{P}^a(\mathbb{R})$. Then β is a direct sum of n line bundles. Assume that m is big enough so that we have a truncated classifying map of β

$$h_\beta : \prod_{j=1}^n \mathbf{P}^a(\mathbb{R}) \rightarrow \mathfrak{G}_{m,n} ;$$

then for every $w^j(\beta)$ defined as above with respect to the given splitting, every $\alpha \in \eta^j(\mathfrak{G}_{m,n})$ such that

$$w^j(\beta) = h_\beta^*(\alpha)$$

is a stable class. For every direct sum of line bundles on some Y , of the form $g^*(\beta)$, then $g^*(w^j(\beta)) \in \eta^j(Y)$ is stable. If ξ is a vector bundle on X and, referring to Proposition 7.26 and adopting those notations, $f_\xi : F(\xi) \rightarrow X$ such that $f_\xi^*(\xi) = g^*(\beta)$ ($Y = F(\xi)$) splits as a sum of line bundles, then every class $\alpha \in \eta^j(X)$ (if any) such that $f_\xi^*(\alpha) = g^*(w^j(\beta))$ is stable.

REMARK 16.4. It is not evident that the construction outlined above leads to non trivial stable classes. Actual non triviality again is part of the construction of Stiefel-Whitney classes that we will not develop here.

16.2. Completeness of stable η -numbers

This “completeness” refers to the fact that the necessary condition to be a boundary stated in Proposition 16.2 is also sufficient. This is an important theorem due to R. Thom [T]. The original proof is an application of the *Pontryagin-Thom construction* that allows to rephrase the study of the cobordism ring η^\bullet in terms of the homotopy theory of certain so called *Thom’s spaces* (see Chapter 17). Here we propose an elementary proof extracted from [BH] which ultimately uses only transversality. Let us state this theorem.

THEOREM 16.5. $[X] = 0 \in \eta_n$ if and only if every stable η -characteristic number vanishes on X .

It is enough to show the “if” implication. This will be an immediate consequence of the next two lemmas.

By the classification of compact 1-manifolds, if $n = 0$ then X is a boundary if and only if it consists of an *even* number of points, thus it is easy to check that Theorem 16.5 holds true for $n = 0$. If $\dim X > 0$, there is a *special case* such that the stable characteristic numbers clearly vanish, that is when (X, s_X) is bordant with a constant map (N, c) ; in other words $[X, s_X]$ belongs to a copy of η_n embedded in $\eta_n(\mathfrak{G}_{m+1, n+1})$. First let us prove that X is a boundary under such a stroger hypothesis.

LEMMA 16.6. Let $\dim X > 0$ and $F : Q \rightarrow \mathfrak{G}_{m+1, n+1}$ realize a bordism of (X, s_X) with a constant map $c : N \rightarrow \mathfrak{G}_{m+1, n+1}$. Then N (hence X) is a boundary.

Proof : The map F pulls back the tautological bundle over the grassmannian to a rank $(n+1)$ vector bundle ξ on Q which restricts to $\tau_X := T(X) \oplus \epsilon^1$ on X and to a trivial bundle ϵ^{n+1} on N . Denote by $D(\xi)$, $S(\xi) = \partial D(\xi)$, the total spaces of the unitary $(n+1)$ -disk and n -sphere bundles of ξ respectively. Similarly denote the restrictions $D(\tau_X)$, $S(\tau_X)$ and $D(\epsilon^{n+1})$, $S(\epsilon^{n+1})$. Let ι be the fibrewise antipodal involution on ξ . Then $S(\xi)$ is a compact $(2n+1)$ -manifold with boundary

$$\partial S(\xi) = S(\tau_X) \amalg S(\epsilon^{n+1})$$

equipped with the involution ι_S (the restriction of ι). Consider the $(2n+1)$ -manifold with boundary

$$Y = X \times X \times [-1, 1]$$

equipped with the involution

$$\sigma(x, y, t) = (y, x, -t)$$

so that ∂Y is an invariant set of σ . The fixed point set of σ is given by

$$\mathcal{X} = \Delta_X \times \{0\} = \{(x, x, 0)\} \subset Y$$

which can be naturally identified with X itself. We can find a tubular neighbourhood U of \mathcal{X} in Y such that by removing the interior of U from Y we get a compact $(2n+1)$ -manifold say Z , with boundary

$$\partial Z = \partial U \amalg \partial Y$$

such that $(Z, \partial Z)$ is invariant for σ and the restriction of σ to ∂U can be identified with the restriction of ι_S to $S(\tau_X)$. Then we can glue Z and $S(\xi)$ along $\partial U \sim S(\tau_X)$ and get a compact $(2n+1)$ -manifold W with boundary

$$\partial W = \partial Y \amalg S(\epsilon^{n+1})$$

equipped with a smooth fixed point free involution say σ_W , which coincides with $\sigma \amalg \iota_S$ on ∂W . Then the quotient space $\mathcal{W} := W/\sigma_W$ is a smooth manifold with boundary such that the quotient map

$$q : W \rightarrow \mathcal{W}$$

is a degree 2 smooth covering map. We note that the restriction of q to ∂Y is a trivial covering, while

$$S(\epsilon^{n+1})/\sigma_W \sim N \times \mathbf{P}^n(\mathbb{R})$$

and the restriction of q to $S(\epsilon^{n+1}) \sim N \times S^n$ may be identified with the map $\text{Id}_N \times s$, $s : S^n \rightarrow \mathbf{P}^n(\mathbb{R})$ being the standard double covering. The associated real line bundle on \mathcal{W} (see Chapter 13) is the pull back by a classifying map

$$\phi : \mathcal{W} \rightarrow \mathbf{P}^a(\mathbb{R})$$

for some a big enough, considered up to homotopy. By the above remark about the restriction of the covering to $\partial \mathcal{W}$, we can assume that $\phi|_{\partial Y}$ is a constant map, while $\phi|_{N \times \mathbf{P}^n(\mathbb{R})}$ is the composition of the projection $N \times \mathbf{P}^n(\mathbb{R}) \rightarrow \mathbf{P}^n(\mathbb{R})$ followed by the inclusion $\mathbf{P}^n(\mathbb{R}) \subset \mathbf{P}^a(\mathbb{R})$. Let $\mathbf{P}^{a-n}(\mathbb{R})$ be a projective subspace of $\mathbf{P}^a(\mathbb{R})$ which intersects $\mathbf{P}^n(\mathbb{R})$ transversely at one point x_0 . We can also assume that $\phi(\partial Y) \cap \mathbf{P}^{a-n}(\mathbb{R}) = \emptyset$, so that $\phi|_{\partial \mathcal{W}} \pitchfork \mathbf{P}^{a-n}(\mathbb{R})$ and

$$\phi|_{\partial Y}^{-1}(\mathbf{P}^{a-n}(\mathbb{R})) = N \times \{x_0\} \sim N.$$

By using usual transversality theorems, finally we can also assume that the whole map ϕ is transverse to $\mathbf{P}^{a-n}(\mathbb{R})$ so that the proper $(n+1)$ -submanifold $(R, \partial R)$ of $(\mathcal{W}, \partial \mathcal{W})$ given by $R = \phi^{-1}(\mathbf{P}^{a-n}(\mathbb{R}))$ is such that $N \times \{x_0\} = \partial R$. This achieves the proof of Lemma 16.6. \square

As Theorem 16.5 holds true for $n = 0$, we will argue by induction on the dimension $n \geq 0$. The inductive step is provided by the following lemma combined with Lemma 16.6.

LEMMA 16.7. *Let $\dim X = n > 0$. Assume that all stable η -characteristic numbers of X vanish, and that Theorem 16.5 holds true for all dimensions m smaller than n . Then (X, s_X) is bordant with a constant map $c : N \rightarrow \mathfrak{G}_{m+1, n+1}$.*

Proof : This proof will be somewhat sketchy and definitely not self-contained within the content of this text. Let us given a triangulation \mathcal{K} of $\mathfrak{G}_{m+1, n+1}$ made by smoothly embedded simplices, whose existence has been evoked in Section 14.9.1 (without a proof). The interior of every such a h -simplex is a submanifold of $\mathfrak{G}_{m+1, n+1}$ diffeomorphic to \mathbb{R}^h and called a (open) h -cell of \mathcal{K} . Alternatively one can use the open cells of the natural cellular decomposition of the Grassmannian

depicted in Section 3.5. For every $0 \leq h \leq \dim \mathfrak{G}_{m+1, n+1}$, the union of the cells of dimension less or equal to h is called the h -skeleton \mathcal{K}_h of \mathcal{K} . Fix a base point x_e in every open cells e , call it the “centre” of the cell. For every h as above, by removing the centre from every h -cell, we get a subspace $\tilde{\mathcal{K}}_h$ of \mathcal{K}_h which retracts to \mathcal{K}_{h-1} . By basic transversality, we may assume that the smooth map s_X misses the centre of every cell of dimension greater than $n = \dim X$; hence, up to (continuous) homotopy we can assume that

$$s_X : X \rightarrow \mathfrak{G}_{m+1, n+1}$$

is continuous with values in the n -skeleton \mathcal{K}_n , it is smooth on $s_X^{-1}(\mathcal{K}_n \setminus \mathcal{K}_{n-1})$ and is transverse to the centre x_e of every n -cell e .

We claim that for every n -cell e , the 0-submanifold $Y := s_X^{-1}(x_e)$ of X consists of an even number of points, that is it is a 0-dimensional boundary. In fact, by collapsing $\mathcal{K}_n \setminus \{e\}$ to one point, we get a projection

$$p_e : \mathcal{K}_n \rightarrow S^n$$

which restricts to a smooth embedding of the n -cell e onto $\mathbb{R}^n \subset \mathbb{R}^n \cup \infty = S^n$, so that we will confuse x_e with $p_e(x_e)$. Then

$$Y = (p_e \circ s_X)^{-1}(x_e)$$

and one easily realizes that

$$[Y] = s_X^*(p_e^*([x_e])) \in \eta^n(X)$$

which vanishes as it is a stable η -characteristic number of X . Fix a small n -ball D around x_e in e . Then

$$s_X^{-1}(D) = (\tilde{D}_1 \cup \tilde{D}_2) \cup \cdots \cup (\tilde{D}_s \cup \tilde{D}_{s+1})$$

and the restriction of s_X to every \tilde{D}_j is a diffeomorphism onto D . Remove from X the interior of every \tilde{D}_j and pairwise glue together the boundary components $\partial\tilde{D}_j$ and $\partial\tilde{D}_{j+1}$, $j = 1, \dots, s$ by means of the above identifications with ∂D . Do it simultaneously at the centre of every n -cell. Then we get a boundaryless n -manifold N_1 such that the map s_X descends to a stable classifying map

$$s_1 = s_{N_1} : N_1 \rightarrow \mathcal{K}_n \subset \mathfrak{G}_{m+1, n+1}$$

which misses the centres of every n -cell, hence up to homotopy we may assume that s_1 takes values in \mathcal{K}_{n-1} , it is smooth on $s_1^{-1}(\mathcal{K}_{n-1} \setminus \mathcal{K}_{n-2})$ and is transverse to the centre of every $(n-1)$ -cell. Moreover, it is not hard to check that by construction (X, s_X) is bordant with (N_1, s_1) , so that also all stable η -characteristic numbers of N_1 vanish.

Now we would proceed by induction on the codimension of the skeleton to eventually reach (N_n, s_n) which takes values in \mathcal{K}_0 and is bordant with (N_{n-1}, s_{n-1}) (hence with the initial (X, s_X)). As the grassmannian is connected, (N_n, s_n) will be homotopic to a required constant map (N, c) , $N = N_n$ (this last step is not necessary if we use the natural cellular decomposition which has only one 0-cell).

So let us assume inductively that for some $h \geq 1$ we have obtained

$$s_h = s_{N_h} : N_h \rightarrow \mathcal{K}_{n-h} \subset \mathfrak{G}_{m+1, n+1}$$

bordant with (X, s_X) , which is smooth on $s_h^{-1}(\mathcal{K}_{n-h} \setminus \mathcal{K}_{n-h-1})$ and transverse to the centre x_e of every $(n-h)$ -cell e . The stable η -characteristic numbers of N_h vanish. By a similar argument as above, for every such a cell e , there is a collapsing projection

$$p_e : \mathcal{K}_{n-h} \rightarrow S^{n-h}$$

which restricts to a smooth embedding of the cell e onto $\mathbb{R}^{n-h} \subset \mathbb{R}^{n-h} \cup \infty = S^{n-h}$; by confusing x_e with $p_e(x_e)$, set $Y = (p_e \circ s_h)^{-1}(x_e)$. We claim that this h -submanifold Y of N_h is a boundary. By the inductive assumption of Lemma

16.7, it is enough to show that every stable η -characteristic number of Y vanishes. We note that, by using the terminology defined in Chapter 17, Y is *framed* that is it has a trivialized tubular neighbourhood $U \sim Y \times D^{n-h}$ in N_h such that the restriction of s_h to U can be identified with the projection $Y \times D^{n-h} \rightarrow D^{n-h}$, where D^{n-h} is a small disk in e around x_e . This implies that a stable classifying map s_Y for Y is given by $s_h \circ j$, where $j : Y \rightarrow N_h$ is the inclusion. Then it is enough to show that for every $\alpha \in \eta^h(\mathfrak{G}_{m+1, n+1})$, $s_Y^*(\alpha) \cap [Y] \in \mathbb{Z}/2\mathbb{Z}$ vanishes. By the geometric definition of the cobordism products, we realize that as an element of $\mathbb{Z}/2\mathbb{Z}$, $s_Y^*(\alpha) \cap [Y]$ equals $s_h^*(p_e^*[x_e] \sqcup \alpha) \cap [N_h]$ which vanishes being a stable η -characteristic number of N_h . Then Y is a boundary of a manifold W . We make a surgery on N_h by replacing the above product neighbourhood $U \sim Y \times D^{n-h}$ with $W \times \partial D^{n-h}$; do it simultaneously at every $(n-h)$ cell. we get a manifold N_{h+1} ; the map s_h descends to $s_{h+1} : N_{h+1} \rightarrow \mathfrak{G}_{m+1, n+1}$ which can be identified with the projection $W \times \partial D^{n-h} \rightarrow \partial D^{n-h}$ at every $(n-h)$ cell. By construction (N_{h+1}, s_{h+1}) is bordant with (N_h, s_h) and this eventually achieves the inductive step.

The proofs of Lemma 16.7 and of Theorem 16.5 are now complete. \square

16.3. On Ω -characteristic numbers

Recall that a compact boundaryless n -manifold X is parallelizable if the tangent bundle admits a global trivialization so that its total space is diffeomorphic to $X \times \mathbb{R}^n$; in such a case X is orientable. If X is parallelizable then any classifying map $t_X : X \rightarrow \mathfrak{G}_{m, n}$ of $T(X)$ is homotopic to a constant map as well as any stable classifying map $s_X : X \rightarrow \mathfrak{G}_{m+1, n+1}$. Then if X is parallelizable and $\dim X = n > 0$ certainly it verifies the hypothesis of Lemma 16.6, hence $[X] = 0 \in \eta_n$. We can strengthen this result.

PROPOSITION 16.8. *Let X be a parallelizable and oriented compact boundaryless n -manifold, $n > 0$. Then $[X] = 0 \in \Omega_n$.*

Proof : It is enough to prove the statement when X is connected. We will use and refine the proof of Lemma 16.6. If $\dim X = n$ is *even*, we can apply such a proof starting from a homotopy $F : X \times [0, 1] \rightarrow \mathfrak{G}_{m+1, n+1}$ between s_X and a constant map. Clearly $X \times [0, 1]$ is orientable. At the end of the proof we may assume that both $\mathbf{P}^a(\mathbb{R})$ and $\mathbf{P}^{a-n}(\mathbb{R})$ are odd dimensional, hence they are both orientable. Then we conclude by means of the oriented version of the transversality theorems.

If $\dim X = n$ is *odd* we modify the construction as follows: we consider

$$Y = X \times X$$

endowed with the involution $\sigma(x, y) = (y, x)$. The fixed point set consists of the diagonal Δ_X which is naturally identified with X itself. A tubular neighbourhood U of Δ_X can be identified with the unitary disk bundle of $T(X)$, hence with the product $X \times D^n$. By removing the interior of U from Y , we get a compact $2n$ -manifold W with boundary $\partial W = X \times S^{n-1}$; σ restricts to a fixed point free involution on W , and can be identified with the fibrewise antipodal map on ∂W , that is the trivial unitary sphere bundle of $T(X)$. Then the proof runs similarly to the one of Lemma 16.6. At the end we can assume that both $\mathbf{P}^a(\mathbb{R})$ and $\mathbf{P}^{a-n+1}(\mathbb{R})$ are orientable and conclude again by oriented transversality. \square

Every η -characteristic number lifts to an Ω -characteristic number (with the obvious meaning of the term) via the forgetting projection

$$\Omega_\bullet \rightarrow \eta_\bullet .$$

If the manifold X is oriented we can consider also the *complexification* $T_{\mathbb{C}}(X)$ of the tangent bundle: every real vector bundle ξ can be complexified to $\xi_{\mathbb{C}}$ via the inclusion $\mathbb{R} \subset \mathbb{C}$ so that every real cocycle defining ξ can be considered as a cocycle defining $\xi_{\mathbb{C}}$. Then $T_{\mathbb{C}}(X)$ corresponds to a classifying map

$$t_{X,\mathbb{C}} : X \rightarrow \mathfrak{G}_{m,n}(\mathbb{C}) .$$

We can apply almost verbatim the above discussion about (stable) characteristic numbers in the present complexified setting (by replacing in particular real with complex line bundles). This gives rise to further Ω -characteristic numbers with values in \mathbb{Z} instead of $\mathbb{Z}/2\mathbb{Z}$. We call generically *stable Ω -characteristic number* one belonging to the union of such two families.

REMARK 16.9. The classical treatment of stable characteristic numbers (classes) takes places in the *singular cohomology ring* of real or complex grassmannians with $\mathbb{Z}/2\mathbb{Z}$ or \mathbb{Z} coefficients (see [MS], [BT]); they are called *Stiefel-Whitney* and *Pontryagin* numbers respectively. As we do not assume any familiarity with singular cohomology, above we have just ‘lifted’ some facts of such a theory in terms of the cobordism rings that we have introduced in a self-contained way. In the case of η , “to lift” is quite appropriate because one can prove (it is non trivial) that for every compact boundaryless n -manifold X , the $\mathbb{Z}/2\mathbb{Z}$ -cohomology $H^j(X; \mathbb{Z}/2\mathbb{Z})$ can be different from 0 only if $0 \leq j \leq n$, is finite dimensional and coincides with the quotient space $\mathcal{H}^j(X; \mathbb{Z}/2\mathbb{Z}) := \eta^j(X) / \ker(\phi^j)$. Hence stable η -characteristic numbers and Stiefel-Whitney numbers are basically the same. In the oriented case, Ω -characteristic numbers are not exhaustive. Our presentation of the matter is necessarily incomplete.

By using Stiefel-Whitney and Pontryagin numbers, we have the following oriented version of Theorem 16.5. The proof [Wall] is more complicated. Parallelizable manifolds as in Proposition 16.8 represent the basic instance for this theorem.

THEOREM 16.10. *Let X be a compact oriented boundaryless n -manifold. Then $[X] = 0 \in \Omega_n$ if and only if all Stiefel-Whitney and Pontryagin numbers of X vanish.*

□

The Pontryagin-Thom construction

The original Pontryagin construction was inventend to rephrase the study of the homotopy groups of spheres in terms of a certain more geometric (hence presumably more accessible at that time, about 1938) bordism theory. Viceversa, later Thom's extension of Pontryagin construction was mainly intended as a way to rephrase the study of η^\bullet (or Ω^\bullet) in terms of the homotopy groups (becomed more accessible at that time, about 1954, after Serre's Thesis) of certain so called Thom's spaces which in a sense generalize the spheres. So the P-T construction is a powerfull bridge between two different ways to approach a same "mathematical reality".

Let us start by describing the Pontryagin construction (introduced in 1938; see the later exposition in [Pont], and also [M1]) . We are primarily interested here in the determination of the homotopy groups

$$\pi_m(S^n, p)$$

for $m, n \geq 1$. By suitable approximation theorems, we know that we can manage with them in purely differential/topological way. We know that

$$\begin{aligned} \pi_1(S^1, p) &\sim \mathbb{Z}, \quad \pi_m(S^1, p) = 1 \text{ for } m > 1, \\ \pi_m(S^n, p) &= 1 \text{ for } n \geq 2, \quad 1 \leq m < n. \end{aligned}$$

Hence we will assume that $m \geq n > 1$. In such a case $\pi_m(S^n, p)$ is abelian, the base point is immaterial and the group can be identified with $[S^m, S^n]$, the set of smooth homotopy classes of maps $f : S^m \rightarrow S^n$. Moreover, it is convenient to extend the discussion to $[M, S^n]$ where M is any *compact, connected boundaryless* smooth m -manifold, $m \geq n \geq 1$.

17.1. Embedded and framed bordism

We have already encountered instances of embedded bordism within a given manifold in Chapter 13. Let us state it in general.

DEFINITION 17.1. Let M be a compact connected boundaryless m -manifold. Let $0 \leq k < m$. Given compact boundaryless smooth k -submanifolds V_0, V_1 of M , we say that V_0 is *bordant with V_1 within M* (and we write $V_0 \sim_{b,M} V_1$) if there is a smooth triad (W, V_0, V_1) , properly embedded into $M \times [a_0, a_1]$, for some $a_0 < a_1$, such that for $j = 0, 1$,

$$\partial W \cap (M \times \{a_j\}) = V_j .$$

The relation " $\sim_{b,M}$ " is an equivalence relation on the set of compact boundaryless k -submanifolds of M : every such a V is in relation with itself because the cylinder $V \times [a_0, a_1]$ properly embeds into $M \times [a_0, a_1]$; the relation is obviously symmetric; as for the transitivity, up to isotopy we can normalize the proper embeddings of the triads (W, V_0, V_1) in such a way that they are locally cylinder-like as above near the boundary. Given properly embedded triads (W, V_0, V_1) in $M \times [a_0, a_1]$, (W', V'_0, V'_1) in $M \times [a'_0, a'_1]$ respectively, such that $V_1 = V'_0$, then we can construct (W'', V_0, V'_1) in $M \times [a_0, a_1 + a'_1 - a'_0]$ just by stacking $M \times [a'_0, a'_1]$ over $M \times [a_0, a_1]$.

We denote by

$$\eta_k^{\text{emb}}(M)$$

the quotient set.

By restriction to *oriented* k -submanifolds of M , we can get an oriented version of the above definition leading to a quotient set

$$\Omega_k^{\text{emb}}(M) .$$

Stress that we are not assuming that M is oriented.

Let M be as above.

DEFINITION 17.2. A compact boundaryless k -submanifold $V \subset M$ is *framed* if it is endowed with a *framing*. This last is of the form

$$\mathfrak{f} = (s_1, \dots, s_{m-k})$$

where

- (1) Every s_j is a nowhere vanishing section of the bundle $i_V^*T(M)$,

$$i_V : V \rightarrow M$$

being the inclusion;

- (2) For every $x \in V$, the vector $s_1(x), \dots, s_{m-k}(x)$ are linearly independent in T_xM ;
- (3) For every $x \in V$, $T_xM = T_xV \oplus F_x$, where $F_x := \text{Span}\{s_1(x), \dots, s_{m-k}(x)\}$.

Hence $x \rightarrow F_x$ defines a smooth field of transverse $(m-k)$ -planes along V tangent to M . The framing provides a global trivialization of the bundle $i_V^*T(M)$, hence of every tubular neighbourhood of V in M constructed by means of such a field. This means in particular that a necessary (and sufficient) condition in order that V admits a framing is that it has globally trivialisable tubular neighbourhoods in M .

We are going to specialize and enhance the embedded bordism to framed submanifolds. First let us extend the definition of framing to properly embedded triads. Let (W, V_0, V_1) be a properly embedded $(k+1)$ -triad in $M \times [a_0, a_1]$; from now on we will assume by default that the embedding is normalized, i.e. cylinder-like near the boundary as above. A framing of the triad in $M \times [a_0, a_1]$ is of the form

$$\mathfrak{f} = (s_1, \dots, s_{m-k})$$

where these are pointwise linearly independent sections of the bundle

$$i_W^*T(M \times [a_0, a_1]) ,$$

induce a smooth field of transverse $(m-k)$ -planes along W tangent to $M \times [a_0, a_1]$, and we require furthermore that the restriction of \mathfrak{f} to the boundary defines a framing of V_j in M , $j = 0, 1$.

DEFINITION 17.3. Let (V_0, \mathfrak{f}_0) and (V_1, \mathfrak{f}_1) framed k -submanifolds of M . We say that (V_0, \mathfrak{f}_0) is *framed bordant with* (V_1, \mathfrak{f}_1) *within* M and we write

$$(V_0, \mathfrak{f}_0) \sim_{fb} (V_1, \mathfrak{f}_1) ,$$

if there is a properly embedded framed triad $((W, V_0, V_1), \mathfrak{f}_W)$ in some $M \times [a_0, a_1]$ such that the restriction of the framing \mathfrak{f}_W to the boundary coincides with the union of the framings \mathfrak{f}_0 and \mathfrak{f}_1 .

Similarly as above, one checks that this defines an equivalence relation on the set of framed k -submanifolds of M , and we denote by

$$\eta_k^{\mathcal{F}}(M)$$

the quotient set.

We develop now also an *oriented* version; we stress that we do it *provided that M itself is oriented*. So not only we require that for every framed k -submanifolds (V, \mathfrak{f}) , V is also oriented; furthermore we impose that for every $x \in V$, the given orientation of $T_x V$ followed by the tranverse orientation of F_x determined by $\mathfrak{f}(x)$ coincides with the given orientation of $T_x M$. Hence it is enough to require that V is *orientable* because the framing together with the orientation of M select the preferred orientation of V . Note that this way recovers the orientation procedure stated in Theorem 8.2. To define the pertinent relation “ \sim_{fob} ” we use *oriented* and framed triads $((W, V_0, V_1), \mathfrak{f}_W)$ properly embedded in some $M \times [a_0, a_1]$, so that the oriented boundary $\partial W = V_0 \amalg -V_1$. This leads to the quotient set

$$\Omega_k^{\mathcal{F}}(M) .$$

17.2. The Pontryagin map

Let us keep the above setting. We establish the following procedure.

- Fix $x_0 \in S^n$. For every $\alpha \in [M, S^n]$, thanks to transversality take $f : M \rightarrow S^n$ belonging to α and such that $f \pitchfork \{x_0\}$.

- $V := f^{-1}(x_0)$ is submanifold of M of dimension $\dim V = k := m - n$. Fix a positive basis \mathcal{B} of $T_{x_0} S^n$ (as usual the unitary sphere is the oriented boundary of the unit disk D^{n+1} of \mathbb{R}^{n+1} endowed with the standard orientation). For every $x \in V$, set

$$\mathfrak{f}(x) = (d_x f)^{-1}(\mathcal{B}) ;$$

by the very definition of transversality, this defines a framing \mathfrak{f} of V in M . Hence we have constructed a framed k -submanifold (V, \mathfrak{f}) of M . We denote by $[V, \mathfrak{f}]$ its class in $\eta_k^{\mathcal{F}}(M)$.

- If M is oriented, then V is also orientable and we select a preferred orientation via the usual rule stated in Theorem 8.2. This eventually leads to

$$[V, \mathfrak{f}] \in \Omega_k^{\mathcal{F}}(M) .$$

We have:

PROPOSITION 17.4. (1) *If M is oriented, let us associate to every $\alpha \in [M, S^n]$ a class $\mathfrak{p}_\Omega(\alpha) = [V, \mathfrak{f}] \in \Omega_k^{\mathcal{F}}(M)$ by means of an arbitrary implementation of the procedure stated above. Then this actually well defines the Pontryagin map*

$$\mathfrak{p}_\Omega : [M, S^n] \rightarrow \Omega_k^{\mathcal{F}}(M) .$$

(2) *If M is non orientable, let us associate to every $\alpha \in [M, S^n]$ a class $\mathfrak{p}_\eta(\alpha) = [V, \mathfrak{f}] \in \eta_k^{\mathcal{F}}(M)$ by means of an arbitrary implementation of the procedure stated above. Then this actually well defines the Pontryagin map*

$$\mathfrak{p}_\eta : [M, S^n] \rightarrow \eta_k^{\mathcal{F}}(M) .$$

Proof : Every implementation of the procedure involves a few arbitrary choices. We have to check that they are immaterial with respect to the framed bordism class of the resulting framed (possibly oriented) manifold (V, \mathfrak{f}) . Given $\alpha \in [M, S^n]$, let us assume first that two implementations just differ by the choice of the maps f_0 and f_1 in α and tranverse to $x_0 \in S^n$. By the basic transversality theorems, we can assume that a homotopy $F : M \times [0, 1] \rightarrow S^n$ which connects f_0 to f_1 is also tranverse to $x_0 \in S^n$; hence $W = F^{-1}(x_0)$ endowed with the framing $x \rightarrow (d_x F)^{-1}(\mathcal{B})$ gives rise to a framed cobordism between (V_0, \mathfrak{f}_0) and (V_1, \mathfrak{f}_1) constructed by means of f_0 and f_1 respectively. Assume now that the two implementations just differ by the choice of the positive bases \mathcal{B}_0 and \mathcal{B}_1 of $T_{x_0} S^n$. Then the resulting framed manifolds (V, \mathfrak{f}_0) and (V, \mathfrak{f}_1) just differ by the framing. As $\text{GL}(n, \mathbb{R})$ is connected, there is a smooth path $\mathcal{B}_t, t \in [0, 1]$, of such bases connecting \mathcal{B}_0 and \mathcal{B}_1 . Clearly this gives rise to a 1-family of framed manifolds of the form (V, \mathfrak{f}_t) , and eventually to a framing of

$V \times [0, 1]$ properly embedded into $M \times [0, 1]$ which realizes a framed bordism between (V, \mathfrak{f}_0) and (V, \mathfrak{f}_1) . Finally, let us assume that we deal with two different points $x_0, x_1 \in S^n$. By the homogeneity of S^n , there is a diffeotopy h_t , $t \in [0, 1]$, of S^n such that $h_0 = \text{Id}_{S^n}$, $h_1(x_0) = x_1$. Given $f_0 \in \alpha$, $f_0 \pitchfork \{x_0\}$, clearly also $f_1 := h_1 \circ f_0$ belongs to α and $f_1 \pitchfork \{x_1\}$. Thanks to the above results, it is enough to show that the framed manifold (V_0, \mathfrak{f}_0) constructed by using x_0, \mathcal{B}, f_0 and the framed manifold (V_1, \mathfrak{f}_1) constructed by means of $x_1, \mathcal{B}_1 := d_{x_0} h_1(\mathcal{B}), f_1$ belong to the same framed cobordism class. This is easy to achieve by using the 1-parameter family of framed manifolds (V_t, \mathfrak{f}_t) constructed by means of $x_t := h_t(x_0), \mathcal{B}_t := d_{x_0} h_t(\mathcal{B}), f_t := f_0 \circ h_t$. We have understood that all these considerations work as well in the oriented setting, as it is easy to see. The proposition is proved. \square

We can state the main result of this Pontryagin construction.

THEOREM 17.5. *Let M be a compact, connected and boundaryless smooth m -manifold, $m \geq n \geq 1$, $k = m - n$. Then:*

1) *If M is oriented, then the Pontryagin map*

$$\mathfrak{p}_\Omega : [M, S^n] \rightarrow \Omega_k^{\mathcal{F}}(M)$$

is bijective.

2) *If M is non orientable, then the Pontryagin map*

$$\mathfrak{p}_\eta : [M, S^n] \rightarrow \eta_k^{\mathcal{F}}(M)$$

is bijective.

Before giving a proof, let us state immediately an interesting corollary, early due to Hopf.

COROLLARY 17.6. *Assume that $\dim M = \dim S^n \geq 1$. Then:*

1) *If M is oriented, then $f_0, f_1 : M \rightarrow S^n$ are homotopic to each other if and only if*

$$\deg_{\mathbb{Z}}(f_0) = \deg_{\mathbb{Z}}(f_1) .$$

2) *If M is non orientable, then $f_0, f_1 : M \rightarrow S^n$ are homotopic to each other if and only if*

$$\deg_{\mathbb{Z}/2\mathbb{Z}}(f_0) = \deg_{\mathbb{Z}/2\mathbb{Z}}(f_1) .$$

Proof : It is enough to show that if the two maps have the same degree, then they are homotopic. As M and the sphere have the same dimension, the respective framed manifolds (V_0, \mathfrak{f}_0) and (V_1, \mathfrak{f}_1) constructed by means of f_0 or f_1 consist of a finite number of (possibly oriented) points. Then it follows from the very definition of \deg_R , $R = \mathbb{Z}, \mathbb{Z}/2\mathbb{Z}$, that they are framed bordant (possibly in the oriented setting) if and only if the two maps have the same degree. The result follows by Theorem 17.5. \square

Proof of Theorem 17.5: We will deal simultaneously with both Pontryagin's maps, understanding the necessary refinement in the oriented setting. Let us show first that the Pontryagin maps are onto. Let (V, \mathfrak{f}) be a framed k -submanifold of M . It is enough to prove that there is a map $f : M \rightarrow S^n$ such that $[(V, \mathfrak{f})]$ is produced by some implementation of the procedure used to define the Pontryagin maps, starting from the map f . As usual let us decompose the sphere as $S^n = D^+ \cup D^-$ such that $D^+ \cap D^- = S^{n-1}$. By the stereographic projection from the northern pole, we can identify D^- with the unit disk D^n ; take $x_0 = 0 \in D^n \subset S^n$. By using the framing \mathfrak{f} , we can define a global trivialization

$$\tau : V \times D^n \rightarrow U$$

of a tubular neighbourhood of V in M , such that the restriction of τ to $V \times \{0\}$ is the identity. Then we can define the map

$$\tilde{f} : U \rightarrow D^n, \tilde{f}(u) := \pi \circ \tau^{-1}$$

π being the projection $V \times D^n \rightarrow D^n$. By construction:

- $\tilde{f} \pitchfork \{0\}$.
- $\tilde{f}^{-1}(0) = V$.
- Up to framed bordism (use again that $\text{GL}(n, \mathbb{R})$ is connected), the framing \mathfrak{f} can be recovered by the usual construction applied to 0 , \tilde{f} and a basis \mathcal{B} of $T_0 D^n$.

By using a collar of ∂U in M and a collar bump function, it is not hard to extend \tilde{f} to a smooth map

$$f : M \rightarrow S^n$$

such that

- $f = \tilde{f}$ on U ;
- The map f sends the complement of U in D^+ and is constantly equal to the northern pole of S^n , say ∞ , on the complement of a slightly bigger tubular neighbourhood of V in M ;
- $f^{-1}(0) = \tilde{f}^{-1}(0) = V$.

By construction such a map f has the desired property. So we have proved that the Pontryagin maps are onto.

Let us prove now that they are injective. Let us say that a map $f : M \rightarrow S^n$ is *in standard form* if it has the qualitative properties of the map f constructed above in order to prove the surjectivity. Let us prove first the result for the restriction to the homotopy classes that admit representatives in normal form.

LEMMA 17.7. *Assume that $f_0, f_1 : M \rightarrow S^n$ are in standard form, let α_0 and α_1 be the respective homotopy classes, and assume that $\mathfrak{p}_*(\alpha_0) = \mathfrak{p}_*(\alpha_1)$. Then $\alpha_0 = \alpha_1$.*

Proof : Let (V_0, \mathfrak{f}_0) and (V_1, \mathfrak{f}_1) be framed manifolds obtained by implementing the procedure with respect to 0 , \mathcal{B} and f_0 or f_1 . By hypothesis there is a properly embedded framed triad $((W, V_0, V_1), \mathfrak{f}_W)$ in $M \times [0, 1]$ which realizes a framed bordism between them. Let us apply to the triad the construction used above to define \tilde{f} . This produces a suitable map

$$\tilde{F} : U_W \rightarrow D^n$$

where U_W is properly embedded relative tubular neighbourhood of W in $M \times [0, 1]$ which restricts to tubular neighbourhoods U_j of V_j in M , $j = 0, 1$. As well as we have extended above \tilde{f} to $f : M \rightarrow S^n$ (in normal form), we can extend \tilde{F} to

$$F : M \times [0, 1] \rightarrow S^n$$

in relative normal form with respect to U_W . As f_0 and f_1 are themselves in normal form by hypothesis, up to diffeotopy we can assume that the restriction of F to the boundary recovers the given maps f_0 and f_1 . Then F establishes a required homotopy between them. □

To achieve the proof of the main theorem, it is enough now to prove that the assumptions in the above lemma are not restrictive. Let $g : M \rightarrow S^n$, it is not restrictive to assume that $g \pitchfork 0$, and let (V, \mathfrak{f}) obtained by implementing the usual procedure with respect to 0 , \mathcal{B} and g . Let $f : M \rightarrow S^n$ be a map in normal form obtained as in the proof of surjectivity from (V, \mathfrak{f}) . Up to diffeotopy we can assume that the tubular neighbourhood U of V which supports \tilde{f} coincides with $g^{-1}(D^-)$ and that eventually g and f coincide on U , both f and g send the complement of

U in D^+ which retracts to ∞ . Using this facts it is an exercise to show that f and g are homotopic. This completes the proof of the main Theorem 17.5. \square

17.3. Characterization of combable manifolds

Recall that a manifold is *combable* if it carries a nowhere vanishing tangent vector field. We are now able to characterize this property.

THEOREM 17.8. *Let M be a compact connected boundaryless smooth manifold. Then M is combable if and only if $\chi(M) = 0$. In particular if $m = \dim M$ is odd, then M is combable.*

Proof : We already know that $\chi(M) = 0$ is a necessary condition. Let us prove the other implication. Let \mathbf{v} any tangent vector field on M with isolated zeros. By using the homogeneity of M , up to a diffeotopy we can assume that there is a chart $\phi : W \rightarrow \mathbb{R}^m$ such that the zeros x_1, \dots, x_k of \mathbf{v} are contained in W and their images are contained in the unitary disk $D^m \subset \mathbb{R}^m$. For simplicity, let us keep the name \mathbf{v} for its expression in such local coordinates, and x_j for the images of the zero sets in D^m . We can fix an auxiliary riemannian metric g on M which looks as the standard euclidean metric g_0 on a neighbourhood of D^m . Fix a system of small pairwise disjoint disks $D_j \subset D^m$, centred at the x_j , $j = 1, \dots, k$. The field $\hat{\mathbf{v}} := \mathbf{v}/\|\mathbf{v}\|_g$ is well defined on $M \setminus \cup_j \text{Int}(D_j)$ and homotopic to the restriction of \mathbf{v} . The restriction of $\hat{\mathbf{v}}$ to $D^m \setminus \cup_j \text{Int}(D_j)$ defines a map

$$\rho : D^m \setminus \cup_j \text{Int}(D_j) \rightarrow S^{m-1} .$$

Assume at first that M is oriented. By the bordism invariance of the degree we have

$$\deg_{\mathbb{Z}}(\rho|_{\partial D^m}) = \sum_j \deg_{\mathbb{Z}}(\rho|_{\partial D_j})$$

and the second term is equal to $\chi(M) = 0$. By Corollary 17.6, $\rho|_{\partial D^m}$ is homotopically trivial, hence can be extended to a map $\hat{\rho} : D^m \rightarrow S^{m-1}$. By matching this last map with the restriction of $\hat{\mathbf{v}}$ to $M \setminus \text{Int}(D^m)$, we eventually get a nowhere vanishing vector field on M . If M is not orientable, arguing similarly as in the proof of Proposition 7.8 we can assume that the local picture at D^m agrees with the one in the oriented case, so we can conclude as well. \square

The above result extends to triads with a very similar proof.

PROPOSITION 17.9. *A smooth triad (W, V_0, V_1) carries a nowhere vanishing triad tangent vector field if and only if the relative characteristic $\chi(W, V_0) = 0$.* \square

17.4. On (stable) homotopy groups of spheres

Accordingly with the basic motivation of the Pontryagin construction, let us manage with

$$\pi_m(S^n) \sim [S^m, S^n] \sim \Omega_{m-n}^{\mathcal{F}}(S^m)$$

for $m \geq n > 1$, in terms of framed bordism. The first step is to transport on $\Omega_{m-n}^{\mathcal{F}}(S^m)$ the group operation of $\pi_m(S^n)$. Recall that the operation of the ordinary bordism modules is induced by the disjoint union of representatives; moreover disjoint union and connected sum belong to the same bordism class; this implies that every ordinary bordism class can be represented by *connected* manifolds. The operation of the framed bordisms of the spheres is in fact an embedded version of the disjoint union, again with the help of connected sum. Let (V_1, \mathbf{f}_1) and (V_2, \mathbf{f}_2)

oriented framed $(m - n)$ -submanifolds of S^m , then the operation on $\Omega_{m-n}^{\mathcal{F}}(S^m)$ is defined by

$$[V_1, \mathfrak{f}_1] + [V_2, \mathfrak{f}_2] = [(V_1, \mathfrak{f}_1) \amalg (V_2, \mathfrak{f}_2)]$$

where we assume at first that the given framed manifolds are embedded into two disjoint copies of S^m , and the disjoint union $(V_1, \mathfrak{f}_1) \amalg (V_2, \mathfrak{f}_2)$ means the framed submanifold of

$$S^m = S^m \# S^m$$

understanding that the connected sum is performed at disks which are respectively disjoint from the two given framed submanifolds. It is not hard to verify that this operation is well defined and recovers (via the Pontryagin map) the usual operation of the homotopy group $\pi_m(S^n)$. By forgetting the embedding, we have immediately a homomorphism of \mathbb{Z} -modules

$$\phi_k : \Omega_k^{\mathcal{F}}(S^m) \rightarrow \Omega_k, \quad k = m - n .$$

REMARK 17.10. In the ordinary setting we have noticed that every class has connected representatives. By means of embedded connected sums performed by attaching embedded 1-handles, we can obtain that also every class in $\Omega_k^{\mathcal{F}}(S^m)$ has representative $[V, \mathfrak{f}]$ with connected V . This is easy if we forget the framing, a bit more demanding taking it into account. We left the details by exercise.

As an immediate corollary of Corollary 17.6, we have

PROPOSITION 17.11. *For every $m \geq 2$, $\deg : \pi_m(S^m) \rightarrow \mathbb{Z}$ is an isomorphism of \mathbb{Z} -modules, and $[S^m, \text{id}_{S^m}]$ is a generator of $\pi_m(S^m)$.*

□

The same result was already known for $m = 1$.

17.4.1. The J -homomorphism. For every $m, n \geq 1$, there is an important homomorphism early defined by Whitehead

$$J : \pi_m(SO(n)) \rightarrow \pi_{m+n}(S^n)$$

which can be naturally expressed in terms of

$$J : \pi_m(SO(n)) \rightarrow \Omega_m^{Ff}(S^{m+n}) .$$

In fact by taking the usual equatorial embedding $S^m \subset S^{m+n}$, every $\alpha \in \pi_m(SO(n))$ can be considered as a framing \mathfrak{f}_α of S^m in S^{m+n} ; hence $J(\alpha) = [S^m, \mathfrak{f}_\alpha]$.

17.4.2. Freudenthal’s homomorphism and stable homotopy groups.

Let $S^m \subset S^{m+1}$ be the usual equatorial embedding. Set $m = k + n$, so that $m + 1 = k + (n + 1)$. If (V, \mathfrak{f}) is an oriented framed k -submanifold of S^m , then we can consider the framed k -submanifold of S^{m+1} , say (V, \mathfrak{sf}) , where the framing \mathfrak{sf} is obtained by completing \mathfrak{f} with the unitary normal vectors along S^m which point toward the northern pole of S^{m+1} . It is easy from the definition of the operation that this induces a \mathbb{Z} -modules homomorphism

$$\mathfrak{s} : \Omega_k^{\mathcal{F}}(S^m) \rightarrow \Omega_k^{\mathcal{F}}(S^{m+1})$$

whence, via the Pontryagin map,

$$\mathfrak{s} : \pi_{n+k}(S^n) \rightarrow \pi_{n+1+k}(S^{n+1})$$

called *Freudenthal suspension homomorphism*. By using the same “general position argument” used for the weak Whitney embedding theorem (Corollary 6.8) we have:

PROPOSITION 17.12. *For every $k \geq 1$,*

1) *If $n \geq k + 1$ then*

$$\mathfrak{s} : \pi_{n+k}(S^n) \rightarrow \pi_{n+1+k}(S^{n+1})$$

is surjective;

2) *If $n \geq k + 2$ then*

$$\mathfrak{s} : \pi_{n+k}(S^n) \rightarrow \pi_{n+1+k}(S^{n+1})$$

is an isomorphism.

□

One says that for every $k \geq 0$, the homotopy groups $\pi_{n+k}(S^n)$ stabilize for $n \geq k + 2$, being all isomorphic to the (by definition) *stable homotopy group* denoted by π_k^∞ .

By keeping the above notations, it is convenient to organize the groups

$$\pi_{n+k}(S^n) \sim \Omega_k^{\mathcal{F}}(S^{n+k})$$

as being indexed by the couples of integers (k, n) , $k \geq 0$, $n \geq 2$, endowed with the lexicographic order. So for every k , by increasing n we encounter a few groups in the “unstable regime”, until we reach

$$\pi_k^\infty \sim \pi_{2+2k}(S^{k+2}) \sim \Omega_k^{\mathcal{F}}(S^{2+2k}) .$$

17.4.3. Homotopy groups of spheres for small k . “Small” will mean $k \leq 3$. Pontryagin himself succeeded to compute by geometric means the cases $k \leq 2$ via his own construction. We will limit to a few indications about these cases, the reader would fill all details by exercise or refer to the exposition [Pont] which contains detailed proofs.

($k = 0$) In agreement with Proposition 17.11, the situation stabilizes immediately:

$$\pi_0^\infty \sim \pi_2(S^2) \sim \mathbb{Z} .$$

($k = 1$) The group in the unstable regime is

$$\pi_3(S^2) \sim \Omega_1^{\mathcal{F}}(S^3)$$

while

$$\pi_1^\infty \sim \Omega_1^{\mathcal{F}}(S^4) \sim \pi_4(S^3) .$$

Let us analyse the first one. Every finite family of embedded say r smooth circles in S^3 can be transformed into the boundary of r pairwise disjoint embedded smooth 2-disks by means of a generic homotopy which is an embedding for every $t \in [0, 1]$ with the exception of a finite number of instants at which two branches of two circles (possibly the same one) cross each other with distinct tangents. Such a generic homotopy induces an embedded framed bordism. So $\Omega_1^{\mathcal{F}}(S^3)$ is generated by classes of the form $[S^1, \mathfrak{f}]$, where S^1 is the standard $S^1 \subset S^2 \subset S^3$ via equatorial embeddings, hence such representatives only differ by the framings. We can take as reference framing \mathfrak{f}_0 the one having as first component a transverse field along a collar of S^1 in the standard 2-disk $D^+ \subset S^2$. In fact $[S^1, \mathfrak{f}_0]$ corresponds to $1 \in \pi_3(S^2)$. In this way every framing is of the form $\mathfrak{f} = h_{\mathfrak{f}}\mathfrak{f}_0$ for a map

$$h_{\mathfrak{f}} : S^1 \rightarrow SO(2) .$$

As $SO(2) \sim S^1$, the class $\alpha_{\mathfrak{f}}$ of $h_{\mathfrak{f}}$ belongs to $\mathbb{Z} \sim \pi_1(SO(2))$. We claim that $[S^1, \mathfrak{f}_1] = [S^1, \mathfrak{f}_2] \in \Omega_1^{\mathcal{F}}(S^3)$ if and only if $\alpha_{\mathfrak{f}_1} = \alpha_{\mathfrak{f}_2}$. In fact if $f : S^3 \rightarrow S^2$ corresponds to (S^1, \mathfrak{f}) via the Pontryagin construction, then one realizes that $\alpha_{\mathfrak{f}}$ coincides with the linking number of two generic fibres of f over two distinct regular

values (this is called the *Hopf number* of f). Two maps with different Hopf number are not homotopic to each other. Then eventually we have that

$$\pi_3(S^2) \sim \Omega_1^{\mathcal{F}}(S^3) \sim \mathbb{Z} .$$

We can also exhibit a geometric very interesting generator. This is the so called *Hopf map*: let S^3 be realized as the unitary sphere in \mathbb{C}^2 and recall that

$$\mathbf{P}^1(\mathbb{C}) \sim S^2$$

the so called *Riemann sphere*. Then the mentioned map is

$$\mathfrak{h} : S^3 \rightarrow S^2$$

given by the restriction of the natural projection $\mathbb{C}^2 \setminus \{0\} \rightarrow \mathbf{P}^1(\mathbb{C})$. One can see that \mathfrak{h} is a fibre bundle map with fibre S^1 ; the union of two distinct fibres is the so called (oriented) *Hopf link* formed by two simply linked unknotted knots in S^2 with linking number equal to 1.

With similar and easier considerations (now every embedding of S^1 is “standard” by dimensional reasons), we see that $\Omega_1^{\mathcal{F}}(S^4)$ is generated by classes of the form $[S^1, f]$, and every framing induces a classifying map $\alpha_f \in \pi_1(SO(3))$; we know that $SO(3) \sim \mathbf{P}^3(\mathbb{R})$ (see Example 6.5), so that $\pi_1(SO(3)) \sim \mathbb{Z}/2\mathbb{Z}$, and eventually

$$\pi_1^{\infty} \sim \Omega_1^{\mathcal{F}}(S^4) \sim \pi_4(S^3) \sim \mathbb{Z}/2\mathbb{Z} .$$

Again we can exhibit geometric generators. We have

$$\mathfrak{s}^{n-2} : \pi_3(S^2) \rightarrow \pi_{n+1}(S^n)$$

then

$$\mathfrak{s}^{n-2}([\mathfrak{h}]) = [\mathfrak{h}_n]$$

for a suitable “suspended Hopf map”

$$\mathfrak{h}_n : S^{n+1} \rightarrow S^n$$

eventually generates $\pi_{n+1}(S^n)$ for $n \geq 3$.

($k = 2$) We have $\pi_4(S^2)$ and $\pi_5(S^3)$ in the unstable range, while $\pi_2^{\infty} \sim \pi_6(S^4)$. It turns out that they are all isomorphic to $\mathbb{Z}/2\mathbb{Z}$. Again we can exhibit geometric generators. In fact the class of the map

$$\mathfrak{g} := \mathfrak{h} \circ \mathfrak{h}_3 : S^4 \rightarrow S^2$$

generates $\pi_4(S^2)$, while

$$\mathfrak{s}^{n-2}([\mathfrak{g}]) := [\mathfrak{g}_n]$$

generates $\pi_{n+2}(S^n)$ for $n \geq 2$.

This is subtler to establish than the previous cases. It follows by the following steps.

(a) The map

$$\pi_4(S^3) \rightarrow \pi_4(S^2), [\alpha : S^4 \rightarrow S^3] \rightarrow [\mathfrak{h} \circ \alpha]$$

is an isomorphism. Assuming it, $\pi_2(S^4) \sim \pi_4(S^3) \sim \mathbb{Z}/2\mathbb{Z}$ by the case $k = 1$.

(b) One constructs an explicit isomorphism

$$\delta : \pi_6(S^4) \rightarrow \mathbb{Z}/2\mathbb{Z} .$$

(c) One proves that

$$\mathfrak{s} : \pi_4(S^2) \rightarrow \pi_5(S^3)$$

is onto. Assuming (a), (b), (c) and recalling that $\mathfrak{s} : \pi_5(S^3) \rightarrow \pi_6(S^4)$ is onto by Proposition 17.12, it follows that also $\pi_5(S^3) \sim \mathbb{Z}/2\mathbb{Z}$.

Let us outline now a proof of these steps.

(a): A basic fundamental tool in homotopy theory is the so called *homotopy long exact sequence of a fibre bundle* (see for instance [Hu], [Hatch]). We apply it to the Hopf fibration $\mathfrak{h} : S^3 \rightarrow S^2$ with fibre S^1 ; extract from the exact sequence the strings

$$\cdots \rightarrow \pi_n(S^1) \rightarrow \pi_n(S^3) \rightarrow \pi_n(S^2) \rightarrow \pi_{n-1}(S^1) \rightarrow \cdots$$

where the middle homomorphism is \mathfrak{h}_* induced by \mathfrak{h} . As $\pi_m(S^1) = 1$ for $m \geq 2$, we get that for $n \geq 3$,

$$\pi_n(S^3) \sim \pi_n(S^2)$$

in particular

$$\pi_4(S^3) \sim \pi_4(S^2)$$

as desired. Note that this also proves again that $\pi_2(S^3) = \pi_2(S^2) \sim \mathbb{Z}$.

(b) This is the most interesting step. To construct the isomorphism δ we will use several facts about surfaces discussed in Chapter 15. Let (V, \mathfrak{f}) be a framed surface in S^6 , representing a class in $\Omega_2^{\mathcal{F}}(S^6)$. Assume that V is connected, then it is orientable of a certain genus $g \geq 0$. By dimensional reasons, up to diffeotopy V is embedded in a standard way in $S^3 \subset S^6$. So only the framing contribution is relevant. Let C be a compact oriented smooth circle on V . The restriction of the framing $\mathfrak{f} = (s_1, \dots, s_4)$ to C can be completed by adding s_5 that is a normal field along C tangent to V which together with an oriented field tangent to C gives the orientation of $T_x V$ at every $x \in C$. In this way we have constructed a framed circle (C, \mathfrak{f}_C) representing an element of $\Omega_1^{\mathcal{F}}(S^6) \sim \mathbb{Z}/2\mathbb{Z}$. Hence we can associate to (C, \mathfrak{f}_C) the corresponding value $q(C) := q([C, \mathfrak{f}_C]) \in \mathbb{Z}/2\mathbb{Z}$. Actually such a value does not depend on the orientation of C . If $L = \amalg_j C_j$ is a disjoint union of smooth circles on V , set

$$q(L) := \sum_j q(C_j) \in \mathbb{Z}/2\mathbb{Z}.$$

It is an istructive exercise to check that the function q defined so far verifies the conditions stated at the end of Chapter 15; hence

LEMMA 17.13. *The map*

$$q_{(V, \mathfrak{f})} : \eta_1(V) \rightarrow \mathbb{Z}/2\mathbb{Z}, \quad q_{(V, \mathfrak{f})}(\alpha) = q(C)$$

provided that C is any smooth circle on V which represents α , is a well defined quadratic enhancement of $(\eta_1(V), \bullet)$

□

Then we can associate to (V, \mathfrak{f}) , the Arf invariant $\text{Arf}(q_{(V, \mathfrak{f})}) \in \mathbb{Z}/2\mathbb{Z}$. With more work one eventually realizes (recall also Remark 17.10) that

PROPOSITION 17.14.

$$\delta : \Omega_2^{\mathcal{F}}(S^6) \rightarrow \mathbb{Z}/2\mathbb{Z}, \quad \delta(\alpha) = \text{Arf}(q_{(V, \mathfrak{f})})$$

provided that (V, \mathfrak{f}) represents α and V is connected, is a well defined isomorphism.

Thus $\Omega_2^{\mathcal{F}}(S^6)$ is isomorphic to the Witt group $W_q^{\mathbf{H}}(\mathbb{Z}/2\mathbb{Z})$ and realizes in a geometric way the formal non trivial enhancement of $\Omega_2 = 0$ mentioned in Section 15.6. $\Omega_2^{\mathcal{F}}(S^6)$ is generated by a framed torus $S^1 \times S^1$ embedded in the standard way into $S^3 \subset S^6$, such that the framing realizes $\mathbf{H}^{1,1}$. Let us outline now the key step in the proof of Proposition 17.14. Let (V, \mathfrak{f}) be as above, let C be smooth circle traced on V , and assume that $q([C, \mathfrak{f}_C]) = 0$. Abstractly we can attach a 2-handle to $V \times [0, 1]$ at $V \times \{1\}$ in such a way that the embedded attaching tube is a tubular neighbourhood of C in V . In this way we have constructed a triad (W, V, V') such that $g(V') = g(V) - 1$. By easy dimensional reasons, we can extend the embedding $V \subset S^6$ to a proper embedding of the triad (W, V, V') into $S^6 \times [0, 1]$. Then one realizes that the condition $q([C, \mathfrak{f}_C]) = 0$ is sufficient (and necessary) in order that

this can be enhanced to a framed bordism between (V, f) and (V', f') for some framing f' . Moreover, $\text{Arf}(q_{(V,f)}) = \text{Arf}(q_{(V',f')})$. By applying several times this argument, starting with an arbitrary (V, f) we eventually reach either a framed sphere which represents the null class or a generating framed torus.

(c) Here we will be very very sketchy. Given $f : S^5 \rightarrow S^3$, let $p, q \in S^3$ regular values such that both inverse images V_p and V_q are contained in $\mathbb{R}^5 \subset S^5$. As $\dim S^3$ is odd, the map

$$V_p \times V_q \rightarrow S^4, (x, y) \rightarrow \frac{y - x}{\|y - x\|}$$

has vanishing \mathbb{Z} -degree. Given $[V, f] \in \Omega_2^{\mathcal{F}}(S^5)$, $V \subset \mathbb{R}^5$, there is a generic projection of V in \mathbb{R}^4 ; we can simplify the crossing points in the image of V in \mathbb{R}^4 and eventually get (V', f') framed bordant with (V, f) , such that $V' \subset S^4 \subset S^5$. Let $f : S^5 \rightarrow S^3$ be associated to (V', f') via the Pontryagin construction. Assuming that $V' = V_p$, the vanishing of the degree of the map constructed as above with respect to f eventually allows us to construct a framing (V', f') representing an element in $\Omega_2^{\mathcal{F}}(S^4)$ whose suspension equals $[V, f]$.

($k = 3$) This remarkably more complicated case was settled (by using the Pontryagin construction) by Rohlin in a series of four papers in 1951-52 of great historical importance, mostly for the relation with the theory of 4-manifolds. We refer to [GM] for the translation (in french) of these papers and wide deep commentaries. Here we limit to state the final results. We will come back on it in Chapter 20, Section 20.6.

qThere is a quaternionic version of the Hopf map (recall Example 6.5)

$$\mathfrak{h}^{\mathbf{H}} : S^7 \rightarrow S^4$$

obtained in the following way. Let us identify \mathbb{R}^4 with \mathbf{H}^2 , with quaternionic coordinates (q_0, q_1) . The unitary sphere S^7 is defined by the equation $|q_0|^2 + |q_1|^2 = 1$. The group of unitary quaternion ($|q| = 1$) $SU(2)$ acts on S^7 by left multiplication. The quotient space is diffeomorphic to S^4 and $\mathfrak{h}^{\mathbf{H}}$ is just the quotient projection. It is a fibre bundle map with fibre S^3 . Then we have:

- $\pi_6(S^3) \sim \mathbb{Z}/12\mathbb{Z}$;
- $\pi_7(S^4) \sim \mathbb{Z} \times \mathbb{Z}/12\mathbb{Z}$ where the first free factor is generated by $[\mathfrak{h}^{\mathbf{H}}]$, the finite factor is generated by the suspension of a generator of $\pi_6(S^3)$;
- For every $n \geq 5$, $\pi_{n+3}(S^n) \sim \mathbb{Z}/24\mathbb{Z}$ and is generated by $\mathfrak{s}^{n-2}([\mathfrak{h}^{\mathbf{H}}])$.

This geometric way of determining the homotopy groups of spheres has been worked out only for $k \leq 3$ as we have outlined above. Presumably the difficulty would increase too much with k . On the other hand, the main interest (especially from the view point of *low dimensional* differential topology) of such a direct method consists in the method itself. Since Serre's thesis ([Se]) powerful tools (including the use of so called *spectral sequences*) have been developed in homotopy theory; being just interested to the final result, the above cases $k \leq 3$ become first "trivial" applications of these potent methods. Moreover, one gets general structural information; for example we have the following Serre's result:

PROPOSITION 17.15. *For every $k \geq 0$ and $n > 1$, the homotopy group $\pi_{n+k}(S^n)$ is finite with the following exceptions:*

- $k = 0$, as $\pi_n(S^n) \sim \mathbb{Z}$;
- $k = 2h - 1$, $n = 2h$, $h > 0$, where $\pi_{n+k}(S^n) \sim \mathbb{Z} \oplus F$, F being a finite group.

□

A great amount of researches concerns the determination of the p -components of these homotopy groups for all primes $p \geq 2$.

Nevertheless, in spite of such powerful tools (see [To]), the full determination of the groups $\pi_{n+k}(S^n)$ has been not achieved (not even of the stable groups π_k^∞); in fact their behaviour for increasing k is apparently quite irregular, does not present any kind of ‘stabilization’.

17.5. Thom’s spaces

Here the purpose is to rephrase for every $k > 0$ the determination of the bordism $\mathbb{Z}/2\mathbb{Z}$ -vector spaces η_k in terms of the homotopy groups of certain so called *Thom’s spaces*, say \mathbf{T}_k^n . Having as ideal model the Pontryagin construction, S^n would be the “Thom space” for the framed bordism $\Omega_k^{\mathcal{F}}(S^{n+k})$.

To rich a setting closer to the Pontryagin construction, let us recover first the “absolute” bordism in terms of embedded one into spheres. For every sphere S^m , $m > k$, consider the sets $\eta_k^{emb}(S^m)$ defined in Section 17.1. By means of the embedded disjoint union already used above to define the operation on $\Omega_k^{\mathcal{F}}(S^m)$, we can endow $\eta_k^{emb}(S^m)$ with a $\mathbb{Z}/2\mathbb{Z}$ -vector space structure, so that the natural map obtained by forgetting the embedding is a $\mathbb{Z}/2\mathbb{Z}$ -linear map:

$$\phi_{k,m} : \eta_k^{emb}(S^m) \rightarrow \eta_k .$$

Via the usual equatorial embedding $S^m \subset S^{m+1}$, we get linear maps

$$\mathfrak{s}_{k,m} : \eta_k^{emb}(S^m) \rightarrow \eta_k^{emb}(S^{m+1}) .$$

By means of general position considerations as in the weak Whitney embedding theorem, and dealing also with proper embeddings into $S^m \times [0, 1]$, we easily have:

- LEMMA 17.16. 1) If $m \geq 2k + 1$, then $\phi_{k,m}$ is onto;
 2) If $m \geq 2k + 2$, then $\phi_{k,m}$ is a isomorphism; moreover $\phi_{k,m} = \phi_{k,m+1} \circ \mathfrak{s}_{k,m}$.

□

• From now on we stipulate that for every $k > 0$ we will take $m \geq 2k + 2$, and set $h = m - k$.

Let M be a $(r + h)$ -manifold which is the interior of a (possibly boundaryless) compact smooth manifold with boundary; let $Y \subset M$ a boundaryless compact r -submanifold. The following facts are now wellknown:

If $f : S^m \rightarrow M$ is transverse to Y , then $V_f = f^{-1}(Y)$ is a compact boundaryless k -submanifold of S^m ; if f_0 and f_1 are homotopic and both transverse to the zero section, then $[V_{f_0}] = [V_{f_1}] \in \eta_k^{emb}(S^m)$. Then by applying the transversality theorems we well define the map

$$[S^m, M] \rightarrow \eta_k^{emb}(S^m), \quad \alpha = [f : S^m \rightarrow M] \rightarrow [f^{-1}(Y)]$$

provided that f is any representative of α transverse to Y . Recall that in our situation

$$[S^m, M] \sim \pi_m(M) .$$

This would suggest to look for such a pair (M, Y) (if any) such that the above map is bijective. Recall that the pair $(S^n, \{x_0\})$ has played this role with respect to the framed bordism $\Omega_k^{\mathcal{F}}(S^{n+k})$.

With this perspective in mind, let us recall a construction already employed in Section 5.8. For every (k, m) as above, $h = m - k$, take the tautological vector bundle

$$\tau : \mathcal{V}(\mathfrak{G}_{m,h}) \rightarrow \mathfrak{G}_{m,h} ,$$

the grassmannian $\mathfrak{G}_{m,h}$ being identified with the zero section of this bundle. As usual present the sphere as $S^m = \mathbb{R}^m \cup \infty$; up to diffeotopy every compact boundaryless k -submanifold V of S^m misses ∞ , that is $V \subset \mathbb{R}^m \subset S^m$. Let

$$\nu : V \rightarrow \mathfrak{G}_{m,h}, \nu(x) = (T_x V)^\perp$$

be the orthogonal distribution of h -planes along V with respect to a riemannian metric on \mathbb{R}^m , for instance the standard one g_0 . We can use ν to build a tubular neighbourhood $p : U \rightarrow V$ of V in \mathbb{R}^m and this can be incorporated into a commutative diagram of maps

$$\begin{array}{ccc} U & \xrightarrow{\tilde{f}} & \mathcal{V}(\mathfrak{G}_{m,h}) \\ \downarrow p & & \downarrow \tau \\ V & \xrightarrow{\nu} & \mathfrak{G}_{m,h} \end{array}$$

where the image of \tilde{f} is a tubular neighbourhood of the zero section in $\mathcal{V}(\mathfrak{G}_{m,h})$, \tilde{f} is a fibred map onto its image, hence transverse to $\mathfrak{G}_{m,h}$, and $\tilde{f}^{-1}(\mathfrak{G}_{m,h}) = V$. Although it would be tempting to take $(M, Y) = (\mathcal{V}(\mathfrak{G}_{m,h}), \mathfrak{G}_{m,h})$, one immediately realizes that there are not reasons that \tilde{f} can be extended to the whole of S^m . The situation is very similar to the step in the proof of the surjectivity of the Pontryagin map when we have constructed the map also called $\tilde{f} : U \rightarrow \mathbb{R}^n$, where $(\mathbb{R}^n, \{0\})$ played the role of $(\mathcal{V}(\mathfrak{G}_{m,h}), \mathfrak{G}_{m,h})$. The key fact that allowed us to extend that \tilde{f} to a map $f : S^m \rightarrow S^n$, was that the complement of the image of \tilde{f} retracts to the northern pole of S^n ; note that $S^n = \mathbb{R}^n \cup \infty$ can be considered as the one-point compactification of \mathbb{R}^n . This suggests a very simple way to compactify $\mathcal{V}(\mathfrak{G}_{m,h})$ in order to make the extension of the map \tilde{f} possible. Set

$$\mathbf{T}_{m,h}^\eta := \mathcal{V}(\mathfrak{G}_{m,h}) \cup \infty$$

that is the one-point compactification. This space has some remarkable features

- It is no longer a manifold; however the only non manifold point is just the added point at infinity;
- This point ∞ has a fundamental system of conical neighbourhoods centred at it and with base diffeomorphic to the total space of the unitary bundle of the tautological bundle τ ;
- The one-point compactification (which is isomorphic to the sphere S^h) of every fibre of τ is embedded into $\mathbf{T}_{m,h}$ which can be considered as the wedge of such infinite family of h -spheres, based at ∞ ;
- $\mathbf{T}_{m,h}^\eta \setminus \mathfrak{G}_{m,h}$ retracts to ∞ .

So although it is not a manifold, $\mathbf{T}_{m,h}^\eta$ is a “honest” rather tame path connected compact space (in particular it has a structure of finite CW complex) whose homotopy groups are suited to be treated by the powerful tools mentioned above.

Then arguing similarly to the Pontryagin construction, we can extend the above map

$$\tilde{f} : U \rightarrow \mathcal{V}(\mathfrak{G}_{m,h})$$

to a map

$$f : S^m \rightarrow \mathbf{T}_{m,h}^\eta$$

such that the complement of U is mapped into the complement of the image of U in $\mathbf{T}_{m,h}^\eta$, f is constantly equal to ∞ on the complement of a slightly bigger tubular neighbourhood say U' of V in S^m , f is smooth on U' . Let us say that a map sharing these properties of f is *in standard form*. Similarly to the end of the proof of Theorem 17.5, we have

LEMMA 17.17. *Every $\alpha \in [S^m, \mathbf{T}_{m,h}^\eta]$ has representatives in standard form.*

Proof : Let $\alpha = [g : S^m \rightarrow \mathbf{T}_{m,h}^\eta]$. Up to a first homotopy we can assume that g is smooth on $D^- \subset S^m$ (as usual $D^- \sim D^m$), $g^{-1}(\infty) \cap D^- = \emptyset$ and $g|_{D^-}$ is transverse to $\mathfrak{G}_{m,h}$. Then we can construct $f : S^m \rightarrow \mathbf{T}_{m,h}^\eta$ in normal form which coincides with g on the tubular neighbourhood U of $V = g^{-1}(\mathfrak{G}_{m,h})$ involved in the construction of \tilde{f} , whence of f itself. Set $A = g(U) = f(U)$. As $\mathbf{T}_{m,h}^\eta \setminus A$ is contractible to ∞ , we can conclude that g and f are homotopic. \square

We summarize the above discussion in the following main result of the present section. Thanks to Lemma 17.17 the proof runs parallel to the one of Theorem 17.5, details are omitted.

THEOREM 17.18. *For every $k > 0$, $m \geq 2k + 2$, $h = m - k$, the map*

$$\mathfrak{t}_{m,h} : [S^m, \mathbf{T}_{m,h}^\eta] \rightarrow \eta_k^{emb}(S^m), \quad \mathfrak{t}_{m,h}(\alpha) = [f^{-1}(\mathfrak{G}_{m,h})]$$

provided that $f : S^m \rightarrow \mathbf{T}_{m,h}^\eta$ is any representative in normal form of α , is well defined and eventually establishes group isomorphisms

$$\pi_m(\mathbf{T}_{m,h}^\eta) \sim \eta_k^{emb}(S^m) \sim \eta_k .$$

\square

Every such a $\mathbf{T}_{m,h}^\eta$ is called a Thom spaces for η_k . Sometimes one prefers to write them as $\mathbf{T}_{k+h,h}^\eta$; the homotopy groups $\pi_{k+h}(\mathbf{T}_{k+h,h}^\eta)$ stabilize when $h \geq k + 2$.

17.5.1. On Thom's spaces for Ω_k . First we identify Ω_k with $\Omega_k^{emb}(S^m)$, $m \geq 2k + 2$. Then we replace the tautological bundle τ with the tautological bundle of the grassmannian of *oriented* h -planes in \mathbb{R}^m (see Chapter 6)

$$\tilde{\tau} : \mathcal{V}(\tilde{\mathfrak{G}}_{m,h}) \rightarrow \tilde{\mathfrak{G}}_{m,h} .$$

Note that the fibres of this bundle are tautologically oriented. Set $\mathbf{T}_{m,h}^\Omega$ the one-point compactification of $\mathcal{V}(\tilde{\mathfrak{G}}_{m,h})$. For every $[V] \in \Omega_k(S^m)$, in a very similar way as above, we can construct

$$\tilde{f} : U \rightarrow \mathcal{V}(\tilde{\mathfrak{G}}_{m,h})$$

which extends to a map in normal form

$$f : S^m \rightarrow \mathbf{T}_{m,h}^\Omega$$

in such a way that the given orientation of V coincides with the one obtained by the usual rule already employed in the Pontryagin construction by means of the orientation of S^m and the transverse orientation to V induced, in that case, by the framing. Arguing similarly to the η -case we eventually get:

THEOREM 17.19. *For every $k > 0$, $m \geq 2k + 2$, $h = m - k$, the map*

$$\tilde{\mathfrak{t}}_{m,h} : [S^m, \mathbf{T}_{m,h}^\Omega] \rightarrow \Omega_k^{emb}(S^m), \quad \tilde{\mathfrak{t}}_{m,h}(\alpha) = [f^{-1}(\tilde{\mathfrak{G}}_{m,h})]$$

provided that $f : S^m \rightarrow \mathbf{T}_{m,h}^\Omega$ is any representative in normal form of α , is well defined and eventually establishes group isomorphisms

$$\pi_m(\mathbf{T}_{m,h}^\Omega) \sim \Omega_k^{emb}(S^m) \sim \Omega_k .$$

\square

Every such a $\mathbf{T}_{m,h}^\Omega = \mathbf{T}_{k+h,h}^\Omega$ is called a Thom spaces for Ω_k ; again the homotopy groups $\pi_{k+h}(\mathbf{T}_{k+h,h}^\Omega)$ stabilize when $h \geq k + 2$.

17.5.2. Determination of η_\bullet . The homotopy groups $\pi_m(\mathbf{T}_{m,h}^\eta)$ look qualitatively simpler than in the case of spheres as we already know for example that they are finite dimensional $\mathbb{Z}/2\mathbb{Z}$ -vector spaces. In fact they can be computed by advanced homotopy theory methods ([Se]), providing the full determination of

$$\eta_\bullet = \bigoplus_k \eta_k .$$

Recall that η_\bullet has furthermore a $\mathbb{Z}/2\mathbb{Z}$ -graded algebra structure where the product is induced by the cartesian product of manifolds:

$$[V] \cdot [W] = [V \times W] .$$

This has been noticed in Remark 11.12; here we omit the cobordism reindexing $\eta_k = \eta_k(x_0) \sim \eta^{-k}(x_0) = \eta^{-k}$. In $[\mathbf{T}]$ one eventually determines these algebra. Here we limit to the statement:

THEOREM 17.20. *The $\mathbb{Z}/2\mathbb{Z}$ -graded algebra η_\bullet is isomorphic to the polynomial algebra*

$$\mathbb{Z}/2\mathbb{Z}[X_i; i \in J]$$

where

$$J = \mathbb{N} \setminus \{2^j - 1; j \in \mathbb{N}\} .$$

□

We can also give explicit geometric generators (see [M5]). For every $m \leq n$, let $H_{m,n}$ denote the regular real algebraic hypersurface in the product of projective spaces $\mathbf{P}^m(\mathbb{R}) \times \mathbf{P}^n(\mathbb{R})$ defined in terms of the respective homogeneous coordinates (w_0, \dots, w_m) and (z_0, \dots, z_n) as the locus

$$H_{m,n} = \{w_0 z_0 + w_1 z_1 + \dots + w_m z_m = 0\} .$$

Set

$$\begin{aligned} \{X_{2^j} &:= [\mathbf{P}^{2^j}(\mathbb{R})], j > 1\} \\ \{X_{2^{k+1}+1} &:= [H_{2^k, 2+2^k}], k > 1\} . \end{aligned}$$

To show that their union is a family of independent generators it is enough to show that for every $i \in J$ there exists a unique representative $X_i = [V_i]$ in the family and that for every finite product of such V_i , there is a non vanishing (stable) η -characteristic number (recall Section 16.2). This last task is easy for even indices 2^j and the E-P characteristic mod(2) suffices. In general it is easier if one would dispose of the cohomological formulation in terms of Stiefel-Whitney numbers (see Remark 16.9).

As a remarkable qualitative consequence we have

COROLLARY 17.21. *For every $k \geq 0$, every $\alpha \in \eta_k$ can be represented by regular real algebraic sets (projective indeed).*

The determination of Ω_\bullet can be performed in the same vein, however the proof, even the statement are more complicated (see [Wall]).

17.5.3. On Nash-Tognoli theorem. We have discussed in Chapter 5 how every compact boundaryless m -submanifold M of \mathbb{R}^n can be approximated by a Nash manifold M' (normal if the embedding dimension is big enough). As already said, in his paper [Na], Nash stated also a few conjectures/questions towards potential improvements of this result (see also Sections 15.5, 19.9). The most natural conjecture was that M can be approximated by a regular real algebraic set (not only by some “analytic sheet” of it). A first step was accomplished In [Wa2] by proving the conjecture under the restrictive hypotheses that the embedding dimension is big enough (as for normality), and $[M] = 0 \in \eta_m$ i.e. it is a boundary $M = \partial W$. Roughly, one realizes the double $D(W) \subset \mathbb{R}^n$ in such a way that M is the transverse intersection of $D(W)$ with a hyperplane P . Then one show that $D(W)$ can be

approximated by a normal Nash manifold N made by regular components of a real algebraic set X such that $X \setminus N$ is far from the hyperplane. Finally $M' = P \pitchfork X$ is a required regular real algebraic approximation of M . Corollary 17.21 can be rephrased by saying that the conjecture holds *up to bordism*. By using this fact, the actual conjecture has been proved in general [Tog], again assuming that the embedding dimension is big enough. By that Corollary, there is a regular m -dimensional real algebraic set Σ such that $M \amalg \Sigma = \partial W$. A suitable *relative approximation theorem* allows us to refine the above construction in such a way that

$$P \pitchfork X = M' \amalg \Sigma ;$$

as both $M' \amalg \Sigma$ and Σ are regular algebraic sets, it is not hard to conclude that also M' is regular algebraic so that it is a required approximation of M . In [Ki], one refines the Nash-Tognoli theorem in the projective setting, and proves that $M \subset \mathbf{P}^n(\mathbb{R})$ can be approximated by regular algebraic subsets of the projective space. For more details about this matter see [BCR].

High dimensional manifolds

“High” means of dimension greater or equal to 6. The reason of this specific opposition “low dimensions less or equal to 5” *vs* “high dimensions greater or equal to 6” mainly depends on the fact that in high dimension Smale’s [S2] *h-cobordism theorem* holds and, moreover, we have a “stable” differential/topological proof, in the sense that it works in the same way for every high dimension. Such a proof definitely does not work for low dimensions. In dimension 5 the *h-cobordism theorem* fails and this reflects specific phenomena of persistent *geometric* intersection between surfaces embedded in boundaryless compact simply connected 4-manifolds, although they have vanishing *algebraic* intersection number. In dimension 4 the proof does not apply because of specific geometric linking phenomena between knots in S^3 with vanishing (algebraic) linking number; the validity of the 4-dimensional *h-cobordism theorem* still is an *open question*. The 3-dimensional *h-cobordism theorem* is equivalent to the celebrated *Poincaré conjecture*; this last has been proved rather recently by means of deep 3-dimensional methods of *geometric analysis*. In a sense dimension 5 is really in the border between the two regimes; as already said, it is influenced by the behaviours of four dimensional manifolds; on the other hand, with some specific additional care, shares some remarkable behaviours with higher dimensions.

In this Chapter we will not provide a proof of the *h-cobordism theorem* (see [M3] for a proof in terms of Morse functions, see [RS] for a proof in terms of handle decompositions which actually works also for PL manifolds); rather we will focus a key point where the high dimensional assumption is crucial.

Together with Chapter 15, Chapters 19 and 20 will be devoted to some aspects of low dimensional theory.

18.1. On the *h-cobordism theorem*

Let us start with a definition.

DEFINITION 18.1. Let (W, V_0, V_1) be a smooth m -dimensional triad ($m = \dim W$). It is a *h-cobordism* if both inclusions $j_i : V_i \rightarrow W$, $i = 0, 1$, are homotopy equivalences (i.e. they have an inverse up to smooth homotopy $r_i : W \rightarrow V_i$ such that (by definition) $r_i \circ j_i$ is homotopic to id_{V_i} , $j_i \circ r_i$ is homotopic to id_W).

The basic example of *h-cobordism* is a cylinder $(V \times [0, 1], V, V)$. The general vague question is under which minimal hypothesis the cylinders are the unique instance of *h-cobordism* up to diffeomorphism of triads. We can formulate the following more specific question:

QUESTION 18.2. (*Simply connected m -dimensional *h-cobordism question**) Let (W, V_0, V_1) be a *h-cobordism*, $\dim W = m$; assume that W (whence both V_0 and V_1) is *simply connected*. Is it true that the triad is diffeomorphic to the cylinder $(V_0 \times [0, 1], V_0, V_1)$, so that, in particular, V_0 is diffeomorphic to V_1 ?

Note that the question is empty for $m = 2$. Assume the positive answer, let us derive some important consequences.

PROPOSITION 18.3. *Assume that m -dimensional simply connected h -cobordisms are diffeomorphic to cylinders. Then we have:*

(1) (Characterization of the m -disk) *Every contractible compact m -manifold M with simply connected boundary is diffeomorphic to the closed disk D^m .*

(2) (Generalized Poincaré conjecture) *If Σ is a compact m -manifold which is homotopically equivalent to S^m (i.e. it is a homotopy sphere), then it is homeomorphic to S^m .*

(3) (Smooth Schoenflies property) *If Σ is a smooth embedded $(m - 1)$ -sphere in S^m , then there is a diffeotopy of S^m that sends Σ onto the standard equator $S^{m-1} \subset S^m$.*

Sketch of proof. Some of the facts claimed below are not so evident; to prove them one would dispose of more advanced algebraic/topological tools; we limit to an outline.

(1) Remove from M a m -disk D standardly embedded into a chart of M . Set $W = M \setminus \text{Int}(D)$. The triad $(W, \partial D, \partial M)$ is a simply connected h -cobordism, hence it is diffeomorphic to the cylinder $(S^{m-1} \times [0, 1], S^{m-1}, S^{m-1})$ and M is diffeomorphic to the manifold obtained by gluing D to this cylinder by a diffeomorphism $\phi : \partial D \rightarrow S^{m-1} \times \{1\}$; it is not hard to conclude that M is diffeomorphic to D^m .

(2) Remove from Σ a standard m -disk D in a chart as above. $M = \Sigma \setminus \text{Int}(D)$ verifies the hypothesis of item (1), then it is diffeomorphic to a disk, Σ is eventually a twisted sphere (see Section 7.5.2) and we know that it is homeomorphic (not necessarily diffeomorphic) to S^m .

(3) By the separation theorem of Section 12.2, $S^m \setminus \Sigma$ has two connected components, the closure of each one of these components verifies the hypothesis of item (1), hence it is an embedded smooth m -disk in S^m and we conclude by means of the uniqueness of disks up to diffeotopy. □

REMARK 18.4. The above proposition shows that the h -cobordism question is strictly related to (in fact motivated by) basic fundamental questions about the topology of smooth manifolds. For example for $m = 3$, if (W, V_0, V_1) is a simply connected h -cobordism, then $V_0 \sim V_1 \sim S^2$ by the classification of surfaces. As a 3-dimensional twisted sphere is a true sphere, it follows that a positive answer to question 18.2 for $m = 3$ is equivalent to the validity of the original celebrated *Poincaré conjecture*, with furthermore the refinement that for $m = 3$ every smooth homotopy sphere Σ is *diffeomorphic* to S^3 . Probably the reader is aware that this has been proved by G. Perelman at the beginning of the new century, by achieving the program based on the Ricci flows of riemannian metrics on 3-manifolds, early introduced by R. Hamilton. We stress that this peculiarly 3-dimensional geometric/analytic approach is very far from the differential/topological methods discussed in this text. As the 3-dimensional Poincaré conjecture is true, then if (W, V_0, V_1) is a simply connected 4-dimensional h -cobordism, then $V_0 \sim V_1 \sim S^3$. Thus, as a twisted 4-sphere is a true sphere, a positive answer to question 18.2 for $m = 4$ is equivalent to the fact that every smooth 4-dimensional homotopy sphere is actually *diffeomorphic* to S^4 . This still is an *open question*, as well as the validity of the 4-dimensional smooth Schoenflies property. On the other hand we recall that the *purely topological* 4-dimensional Poincaré conjecture (even dealing with topological not necessarily smooth 4-manifolds) has been proved in 1982 by M.H. Freedman [Fr].

Now we can state the *high dimensional simply connected h -cobordism theorem*.

THEOREM 18.5. *Let (W, V_0, V_1) be a simply connected h -cobordism, $\dim W \geq 6$. Then it is diffeomorphic to the cylinder $(V_0 \times [0, 1], V_0, V_0)$.*

Hence all consequences stated in Proposition 18.3 hold for $m \geq 6$. We have mentioned before that although the h -cobordism theorem fails for $m = 5$, nevertheless this dimension shares some behaviour with higher dimensions. Referring to the statement of Proposition 18.3, we recall for example (without proof) that:

- (1) The characterization of the 5-disk holds under the *stronger* hypothesis that the boundary of the contractible 5-manifold M is *diffeomorphic* to S^4 ;
- (2) The 5-dimensional generalized Poincaré conjecture holds true;
- (3) The 5-dimensional smooth Schoenflies property holds true.

18.1.1. On the proof of the high dimensional h -cobordism theorem.

The strategy to prove the h -cobordism theorem is based on handle decompositions (refer to Chapter 9). Given a simply connected h -cobordism (W, V_0, V_1) , $\dim W = m$, one can start with an ordered handle decomposition

$$C_0 \cup H_1^{q_1} \cup \dots \cup H_k^{q_k} \cup C_1$$

without 0- and m -handles (Proposition 9.12). If necessary we can also assume that the handles of a given index $q < m$ are attached simultaneously at pairwise disjoint attaching tubes. Note also that in the hypothesis of the theorem, all involved manifolds (W and all submanifolds W_r of W obtained by attaching till the r th-handle) are orientable. We dispose of two basic handle moves in order to try to make it simpler and simpler. If we succeed to eventually reach a decomposition without handles of any index, then the theorem will be proved. A priori the only way we dispose to reduce the number of handles is the cancellation of pairs of complementary handles. The core of the proof is a much more flexible *cancellation theorem* which applies in the setting of the theorem. Consider a fragment of a given handle decomposition of the form

$$\dots \cup H_r^q \cup H_{r+1}^{q+1} \cup \dots$$

Then both the (embedded) b -sphere S_b of H_r^q and the a -sphere S_a of H_{r+1}^{q+1} are submanifolds of ∂W_r and $\dim S_b + \dim S_a = \dim \partial W_r = m - 1$. So fixing auxiliary orientations, we can compute their intersection number in ∂W_r , $[S_b] \bullet [S_a] \in \mathbb{Z}$.

DEFINITION 18.6. In the situation depicted above, we say that $H_r^q \cup H_{r+1}^{q+1}$ is a pair of *algebraically complementary handles* if $[S_b] \bullet [S_a] = \pm 1$.

Obviously this extends the notion of complementary handles. Now we can state a *stronger cancellation theorem*.

THEOREM 18.7. *Let (U, Z_0, Z_1) be a smooth triad of dimension m which admits a handle decomposition*

$$C_0 \cup H^q \cup H^{q+1} \cup C_1$$

made by two algebraically complementary handles. Assume that both Z_0 and Z_1 are simply connected, and that

$$m \geq 6, \quad q \geq 2, \quad m - q \geq 4 .$$

Then the given triad is diffeomorphic to the cylinder $(Z_0 \times [0, 1], Z_0, Z_0)$.

The idea in order to prove the stronger cancellation theorem is clear. By transversality and handle sliding, we can assume that $S_b \pitchfork S_a$ in ∂M , $M := C_0 \cup H^q$ and that the intersection consists of an odd number of signed points, such that the sum of the signs is equal to ± 1 . So by means of handle sliding, one would progressively cancel pairs of intersection points of *opposite sign*, so that at the end one reaches a decomposition made by two genuine complementary handles which can be cancelled. In the discussion on the strong Whitney embedding theorem (Section 7.7) of compact n -manifolds into \mathbb{R}^{2n} , for $n \geq 3$, we have already mentioned the

so called “*Whitney trick*” as a tool in order to cancel pairs of crossing points. The hypotheses of the stronger cancellation theorem allow to apply it. This will be discussed with some care in the next section.

18.2. Whitney trick and unlinking spheres into a sphere

First we state a lemma under the hypotheses of the stronger cancellation theorem.

LEMMA 18.8. *In the hypotheses of Theorem 18.7, denote by $\partial(C_0 \cup H^q) = Z_0 \amalg M$, so that the b -sphere S_b of H^q and the a -sphere S_a of H^{q+1} are transverse submanifolds of M . Then $M \setminus (S_b \cup S_a)$ is simply connected.*

Proof : Set $m = n + 1$. Denote by S'_a the a -sphere of H^q . Its codimension $\dim Z_0 - \dim S'_a = n - (q - 1) \geq 4$. Then by transversality also $Z_0 \setminus S'_a$ is simply connected; as both $Z_0 \setminus S'_a$ and $M \setminus S_b$ retract onto $Z_0 \setminus \text{Int}(T'_a)$, it follows that also $M \setminus S_b$ is simply connected. The codimension of S_a is $\dim M - q = n - q \geq 3$. So by the same transversality argument we have that $(M \setminus S_b) \setminus S_a = M \setminus (S_b \cup S_a)$ is simply connected. □

Referring to the last lemma, we can abstractly formalize some features of the situation occurring on the manifold M .

By a situation $(M, R, S, \pm x)$ of type $(n, r) \in \mathbb{N}^2$ we mean:

- M is a connected oriented boundaryless smooth manifold of dimension n ;
- R and S are boundaryless compact connected oriented submanifolds of M such that $\dim R = r$, $\dim S = s$, $n > s \geq r > 0$, $r + s = n$, $R \pitchfork S$.
- $M \setminus (S \cup R)$ is simply connected;
- $x_{\pm} \in R \cap S$ are intersection points of *opposite sign*.

REMARKS 18.9. (1) In a situation of type (n, r) as above, if both codimensions of S and R are greater or equal to 3, then by an usual transversality argument, $M \setminus (S \cup R)$ is simply connected if and only if M is simply connected.

(2) In situations arising under the hypotheses of Theorem 18.7, we have furthermore that $n \geq 5$ and $r \geq 2$.

(*Whitney disk*) Let $(M, R, S, \pm x)$ be a situation of type (n, r) . By a *Whitney disk* D for $(M, R, S, \pm x)$ we mean the realization of the following pattern (recall Section 7.7)

(1) There is an embedded smooth circle γ in $R \cup S$ with two corners at $\pm x$; these divide γ in two arcs with closures say γ_R and γ_S respectively; γ_R (resp. γ_S) is contained into an smooth open r -disk (s -disk) $U_R \subset R$ ($U_S \subset S$); $U_R \cup U_S$ is a neighbourhood of γ in $R \cup S$; $U_R \pitchfork U_S = \{\pm x\}$ and $U_R \cup U_S$ does not contain other points of $R \cap S$;

(2) There are:

- a 2-disk \mathcal{D} in \mathbb{R}^2 with boundary $\partial\mathcal{D}$ with two corners a_1, a_2 which is contained in the union of two smooth arcs say λ_R, λ_S in \mathbb{R}^2 which intersect transversely at $\{a_1, a_2\}$;
- an embedding $\psi : U \rightarrow M$ where U is a closed 2-disk in \mathbb{R}^2 containing $\mathcal{D} \cup (\lambda_R \cup \lambda_S)$, such that

- $\psi(\lambda_*) \subset U_*$, $* = R, S$;
- $\psi(\partial\mathcal{D}, \{a_1, a_2\}) = (\gamma, \{q_1, q_2\})$;
- for every $x \in \lambda_*$, $d_x\psi(T_x U) \cap T_{\psi(x)}U_* = d_x\psi(T_x \lambda_*)$;
- $\psi(\text{Int}(\mathcal{D})) \subset M \setminus (R \cup S)$.

We summarize (1) and (2) by saying that the smooth 2-disk with corners $D := \psi(\mathcal{D})$ is *properly embedded* into $(M, R \cup S)$ and *connects the crossing points* $\pm x$. Moreover, we require:

(3) We can extend the embedding ψ to a parametrization of a neighbourhood of D in M by a *standard model*, that is to an embedding

$$\Psi : U \times \mathbb{R}^{r-1} \times \mathbb{R}^{s-1} \rightarrow M$$

such that $\Psi(\lambda_R \times \mathbb{R}^{r-1} \times \{0\}) = U_R$ and $\Psi(\lambda_S \times \{0\} \times \mathbb{R}^{s-1}) = U_S$.

REMARK 18.10. We stress that the existence of a Whitney disk (in particular condition (3)) for a situation (M, R, S, x_0, x_1) implies that the two points are necessarily of opposite sign.

(*Whitney trick*) The Whitney trick applies to $(M, R, S, \pm x)$ at a Whitney disk connecting $\pm x$: thanks to the standard model, such a Whitney disk can be easily used as a guide to construct an isotopy of R in M with support not intersecting the other points of $R \cap S$ and carrying R to $R' \pitchfork S$ such that $R' \cap S = R \cap S \setminus \{\pm x\}$ (recall Figure 1 of Chapter 7, by renaming $R = P$, $S = Q$).

DEFINITION 18.11. For every type (n, r) as above, we say that **WT** (n, r) holds if every situation $(M, R, S, \pm x)$ of type (n, r) admits a Whitney disk.

We are going to relate the validity of **WT** (n, r) with a certain *unlinking property* of *unknotted spheres* into a sphere.

A smooth p -sphere $\Sigma \subset S^k$, $k > p \geq 1$, is *unknotted* if it is the boundary of a smooth $(p+1)$ -disk embedded into S^k . The following lemma is easy, by using the unicity of disks up to diffeotopy.

LEMMA 18.12. *Let $\Sigma \subset S^k$ be unknotted. Let D be a smooth k -disk in S^k disjoint from Σ . Then Σ is the boundary of a smooth $(p+1)$ -disk embedded into $S^k \setminus D$.*

□

A *link of unknotted spheres* (S^k, Σ, Σ') of type $(k, p) \in \mathbb{N}^2$ consists of two disjoint unknotted smooth spheres $\Sigma, \Sigma' \subset S^k$ such that

$$p = \dim \Sigma, \quad q = \dim \Sigma', \quad p \leq q, \quad k = p + q + 1 .$$

Such a link (S^k, Σ, Σ') is (geometrically) *unlinked* if the two spheres are the boundary of disjoint $(p+1)$ - and $(q+1)$ -disks respectively. By using again the unicity of disks up to diffeotopy, we have

LEMMA 18.13. *Up to diffeotopy there is a unique unlinked link of type (k, p) .*

□

For every link (S^k, Σ, Σ') , give the spheres auxiliary orientations; then we can define the *linking number* (recall Section 12.4 and Remarks 12.4)

$$lk(\Sigma, \Sigma') \in \mathbb{Z} .$$

A link is *algebraically unlinked* if

$$lk(\Sigma, \Sigma') = 0 .$$

We know (see the end of Section 12.5) that the choice of auxiliary orientations is immaterial with respect to the vanishing of the linking number; moreover this property is symmetric: $lk(\Sigma, \Sigma') = 0$ if and only if $lk(\Sigma', \Sigma) = 0$. Obviously, geometrically unlinked links are algebraically unlinked.

DEFINITION 18.14. For every link type $(k, p) \in \mathbb{N}^2$, we say that the *unlinking property* **U** (k, p) holds, if every link (of unknotted spheres) (S^k, Σ, Σ') of type (k, p) which is algebraically unlinked is in fact geometrically unlinked.

It follows from the above discussion that Theorem 18.7 will be a corollary of item (1) in the next proposition.

PROPOSITION 18.15. (1) For every type (n, r) such that $n \geq 5$ and $r \geq 2$, $\mathbf{WT}(n, r)$ holds.

(2) For every link type (k, p) such that $k \geq 4$, $\mathbf{U}(k, p)$ holds.

Proof : First let us prove that $\mathbf{U}(k, 1)$ holds for every $k \geq 4$; for consider an algebraically unlinked link (S^k, Σ, Σ') , $\dim \Sigma = 1$, $\dim \Sigma' = q = k - 2 \geq 2$. Then $S^k \setminus \Sigma'$ is homotopically equivalent to the standard $S^1 \subset S^k$ and the embedding of Σ in $S^k \setminus \Sigma'$ is homotopically trivial; as $k > 2 \dim \Sigma + 1 = 3$, then Σ is isotopic in $S^k \setminus \Sigma'$ onto a geometrically unlinked circle.

Next we prove the following claim.

Claim 1 For every $n \geq 5$, If $\mathbf{WT}(n, r)$ holds, then $\mathbf{U}(n, \min(r, q))$, $q = n - r - 1$, holds.

Proof of the claim: Consider an algebraically unlinked link (S^n, Σ, Σ') , $\dim \Sigma = r$, $\dim \Sigma' = q$. Assume for simplicity that $r \leq q$. Let $D \subset S^n$ be a $(q + 1)$ -disk such that $\partial D = \Sigma'$. Then the intersection number $[\Sigma] \bullet [D]$ in $S^n \setminus \Sigma'$ is equal to $0 \in \mathbb{Z}$. Then as $\mathbf{WT}(n, r)$ holds, Σ is isotopic to say Σ'' such that $\Sigma'' \cap D = \emptyset$. We can assume that Σ'' is embedded into $S^n \setminus B$ where $B \sim D^n$ is a n -disk of S^n which thickens D . Then we conclude by means of Lemma 18.12.

Next we propose two ways to conclude. The first way consists in a direct proof of item (1); then item (2) will follow as a corollary of Claim 1 and the case $\mathbf{U}(k, 1)$ already achieved. By the second way both statements will be proved simultaneously by implementing the *concatenated inductive scheme* obtained by combining Claim 1 with the following Claim 2 (the case $\mathbf{U}(k, 1)$ being the initial step of this induction):

Claim 2 For every $k \geq 4$, if $\mathbf{U}(k, p)$ holds, then $\mathbf{WT}(k + 1, p + 1)$ holds.

The second way makes fully manifest the strict relationship between \mathbf{WT} and \mathbf{U} . The presentation of this second way is very close to Chapter 5 of [RS].

Proof of item (1): As $n \geq 5$, by general position we can assume that points (1) and (2) in the definition of a Whitney disk for $(M, R, S, \pm x)$ are fulfilled. It remains to achieve point (3). This is rephrased in terms of a suitable configuration of subbundles of $T(M)$ over $(D, \partial D)$. We can assume that an auxiliary Riemannian metric g on M is fixed in such a way that R and S are orthogonal at their intersection points, the normal bundles and the associated tubular neighbourhoods are constructed by means of g . We use the notation $\nu_X Y$ to mean the normal bundle of Y in X . The tangent bundle $T(R)$ splits over γ_R as

$$T(R)|_{\gamma_R} = T(\gamma_R) \oplus E_R$$

where E_R is a rank- $(r - 1)$ subbundle of $(\nu_M D)|_{\gamma_R}$. Thus E_R is tangent to R and normal to D . The normal bundle $\nu_M S$ splits over γ_S as

$$(\nu_M S)|_{\gamma_S} = \nu_D \gamma_S \oplus E_S$$

where E_S is a rank- $(r - 1)$ subbundle of $(\nu_M D)|_{\gamma_S}$. Thus E_S is normal to both S and D . E_R and E_S match at the intersection points $\pm x$, so that we have a rank- $(r - 1)$ bundle E defined over the whole ∂D . By construction E is tangent to R and normal to S . We claim that E can be extended to a subbundle of the whole $\nu_M D$. By means of a trivialization of $\nu_M D$ we can encode E as a map $E : \partial D \rightarrow \mathfrak{G}_{n-2, r-1}$. Then E extends if and only if it is homotopically trivial. It is known that under our dimensional hypotheses (see for instance [Steen])

$$\pi_1(\mathfrak{G}_{n-2, r-1}) = \mathbb{Z}/2\mathbb{Z}$$

and that E as above is homotopically trivial if and only if the corresponding rank- $(r-1)$ bundle is *orientable*. This is actually the case because the intersection points have opposite signs. At this point it is not hard to build compatible trivializations of the bundles considered so far and achieve point (3) in the definition of a Whitney disk.

A sketch of proof of Claim 2: Let $(M, R, S, \pm x)$ of type $(k+1, p+1)$, $k \geq 4$. Argue as in the above proof of item (1), so that we can assume that points (1) and (2) in the definition of a Whitney disk for $(M, R, S, \pm x)$ are fulfilled. Again it remains to achieve point (3). Assume that it holds. We analyze the standard model and then we transport the conclusions in M around the disk D by means of the embedding Ψ . Up to corner smoothing, $B := U \times D^p \times D^{k-p-1}$ is a $k+1$ -disk, and

$$(\partial B, \partial(\lambda_R \times D^p \times \{0\}), \partial(\lambda_S \times \{0\} \times D^{k-p-1}))$$

is diffeomorphic to an unlinked link of type (k, p) . Moreover, the whole B can be reconstructed from such an unlinked link. Assume now that a priori only (1) and (2) are verified. We can nevertheless find a smooth $(k+1)$ -disk B in M around D , which retracts to D , such that

$$\partial B \pitchfork U_R := \Sigma_R, \quad \partial B \pitchfork U_S := \Sigma_S$$

are smooth spheres in the sphere $\partial B \sim S^k$ forming a link of type (k, p) . In order to incorporate it in a standard model, by Lemma 18.13 it is enough to prove that it is unlinked. As $\pm x$ have opposite signs, it follows that the link is algebraically unlinked, and we can conclude because $\mathbf{U}(k, p)$ holds by the hypothesis of Claim 2.

The Proposition is proved. □

REMARK 18.16. As for low dimensions we note that:

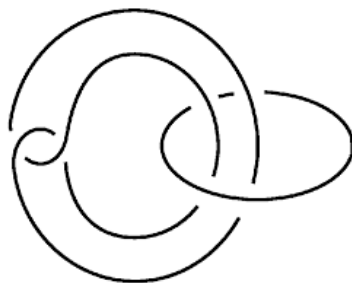

FIGURE 1. Whitehead's link.

- $\mathbf{U}(3, 1)$ fails. The simplest counterexample is the so called *Whitehead link*; several classical knot invariants show that it is geometrically linked in spite of the fact that it is algebraically unlinked (see [Rolf]).

- Trying to perform the construction in order to approach $\mathbf{WT}(4, 2)$, it is not hard to realize item (1) in the definition of Whitney disk; however (2) and even more (3) are very problematic - in fact we will see in Chapter 20 that there are actual obstructions.

On 3-manifolds

In this chapter we will apply several results established so far to compact 3-manifolds. We stress that we will develop a few themes based on classical differential/topological tools, mainly on transversality. In no way we will touch Thurston's *geometrization* approach that has dominated the study of 3-manifolds in last decades. We will not even touch fundamental results in 3-dimensional geometric topology such as the decomposition in prime manifolds or the so called *JSJ*-decomposition. We will provide elementary and selfcontained proofs of the primary fact that compact orientable boundaryless 3-manifolds are parallelizable. An important amount of the chapter will be devoted to several proofs of " $\Omega_3 = 0$ " and of the equivalent Lickorish-Wallace theorem about 3-manifolds up to surgery equivalence respectively. Every proof will illuminate different facets of the matter. We will study the behaviour of surfaces immersed or embedded in a given 3-manifold M , including the determination of the bordism group $\mathcal{I}_2(M)$ of immersed surfaces. An emerging theme will be the quadratic enhancement of the intersection forms of surfaces immersed in 3-manifolds. This will occur also in the classification of 3-manifolds up to equivalence relations defined in terms of blowing up along smooth centres.

19.1. Heegaard splitting

Let M be a connected, *orientable*, boundaryless compact 3-manifold. We know that there is an ordered handle decomposition \mathcal{H} of M with only one 0-handle, only one 3-handle, and such that both 1- and 2-handles respectively are attached simultaneously at disjoint attaching tubes. Denote by M_1 the submanifolds with boundary of M obtained by attaching the 1-handles at the boundary of the unique 0-handle. As M is orientable, then also M_1 is orientable; by the uniqueness of disks up to diffeotopy applied to the attaching tubes of 1-handles and handle sliding, M_1 only depends up to diffeomorphism on the number say $g \geq 0$ of 1-handles and is called a *handlebody of genus g* , denoted by \mathfrak{H}_g . Its boundary $\Sigma = \partial M_1$ is a surface of genus g , that is diffeomorphic to the connected sum of g copies of the torus $S^1 \times S^1$. If $g = 1$, $\mathfrak{H}_1 = D^2 \times S^1$ is also called a *solid torus*. Consider the dual handle decomposition $\tilde{\mathcal{H}}$, so that the 2-handles of \mathcal{H} become the 1-handles of $\tilde{\mathcal{H}}$. Apply the above discussion to \tilde{M}_1 . Then $\partial M_1 = \partial \tilde{M}_1 = \Sigma$ and also \tilde{M}_1 is a handlebody of genus g . Then

$$M = M_1 \cup \tilde{M}_1$$

is called a *Heegaard splitting* of M of genus g and the separating surface Σ is the corresponding *Heegaard surface*.

So every such an M admits a Heegaard splitting of some genus and we can define the *Heegaard genus* $g_H(M)$ of M as the minimum g such that M has a splitting of genus g . As it often happens such an invariant is easy to define but in general hard to compute or even to estimate.

Up to diffeomorphism, a Heegaard splitting of M can be described equivalently as follows: fix a standard model \mathfrak{H}_g of genus g handlebody (for instance embedded in \mathbb{R}^3 and endowed with the standard induced orientation); let $\Sigma_g = \partial \mathfrak{H}_g$ with the boundary orientation. Fix an auxiliary smooth automorphism γ of Σ_g which

reverses the orientation. Then there is an orientation *preserving* (say “positive”) smooth automorphism $\phi \in \text{Diff}^+(\Sigma_g)$ such that

$$M = M_1 \cup \tilde{M}_1 \sim \mathfrak{H}_g \amalg_{\gamma \circ \phi} \mathfrak{H}_g .$$

Moreover, we know that up to diffeomorphism the last term only depends on the isotopy class of ϕ ; in other words, define

$$\text{Mod}(\Sigma_g) := \text{Diff}^+(\Sigma_g)/\text{Diff}^0(\Sigma_g)$$

that is the quotient group mod the normal subgroup of automorphisms isotopic to the identity. This is called the *mapping class group* of Σ_g (also called its *modular group*) and is an object of main importance and interest. Then every splitting is of the form

$$M \sim \mathfrak{H}_g \amalg_{[\phi]} \mathfrak{H}_g \sim \mathfrak{H} \amalg_{\gamma \circ \phi} \mathfrak{H}_g, \quad [\phi] \in \text{Mod}(\Sigma_g) .$$

EXAMPLE 19.1. (1) If $g_H(M) = 0$ then M is a twisted hence a true smooth 3-sphere.

(2) The 3-manifolds such that $g_H(M) = 1$ are classified and called *lens spaces* [Brod]. Let us recall the main facts. Realize the torus as the quotient manifold $\mathbb{R}^2/\mathbb{Z}^2$. The matrix group $SL(2, \mathbb{Z})$ acts linearly on \mathbb{R}^2 by preserving the lattice \mathbb{Z}^2 . Then the action descends to the quotient. In fact one can prove that

$$\text{Mod}(\Sigma_1) \sim SL(2, \mathbb{Z}) .$$

Fix an identification of the torus as the boundary Σ_1 of \mathfrak{H}_1 in such a way that the circle image in $\mathbb{R}^2/\mathbb{Z}^2$ of the x -axis of \mathbb{R}^2 becomes a *meridian* m that is it bounds a 2-disk properly embedded into $(\mathfrak{H}_1, \Sigma_1)$, while the image of the y -axis is a longitude l which intersects transversely m at one point; m, l form a basis of $\Omega_1(\Sigma_1) \sim \mathbb{Z}^2$. Let $A \in SL(2, \mathbb{Z})$, so that $A(m) = pm + ql$, $\gcd(p, q) = 1$. Denote by $L_{p,q}$ the resulting lens space obtained by using A as gluing map. It is not hard to check via Van Kampen theorem that $\pi_1(L_{p,q}) \sim \mathbb{Z}/p\mathbb{Z}$. Then $L(p, q)$ is diffeomorphic to $L(p, q')$ if and only if

$$\pm q' = q^{\pm 1} \pmod{p} .$$

For higher genus the situation is much more complicated.

19.1.1. Heegaard diagrams and a diagrammatic “calculus”. Heegaard splittings can be encoded by means of suitable Heegaard diagrams.

DEFINITION 19.2. A *genus g Heegaard diagram* consists of a triple (Σ, C^-, C^+) where

- (1) Σ is a surface of genus g ;
- (2) $C^\pm = \{c_1^\pm, \dots, c_g^\pm\}$ is a family of g disjoint simple smooth circles on Σ whose union does not divide Σ , that is by removing from Σ the interiors of small pairwise disjoint annular neighbourhoods of these circles we get a 2-sphere with $2g$ holes;
- (3) $C^- \pitchfork C^+$, that is the union of the c_j^- 's is transverse to the union of the c_j^+ 's.

Given a Heegaard diagram we can construct a 3-manifold M endowed with an Heegaard splitting as follows. Take the product $\Sigma \times [-1, 1]$ and stipulate that the circle of C^\pm are traced on

$$\Sigma \times \{\pm 1\} := \Sigma^\pm .$$

Σ is identified with the separating surface $\Sigma \times \{0\}$. Then take a system of pairwise disjoint annular neighbourhoods say T_j^\pm for C^\pm on Σ^\pm . Consider the T_j^+ as a system of attaching tubes of disjoint 2-handle attached to $\Sigma \times [0, 1]$ at Σ^+ . Thanks to the properties of the circles in C^+ this produces a 3-manifold with boundary diffeomorphic to $\Sigma \amalg S^2$. By filling the spherical component with a 3-handle we

get the piece \tilde{M}_1 of the desired handle decomposition of M . Doing similarly on the other side $\Sigma \times [-1, 0]$ we get the piece M_1 and eventually the splitting

$$M \sim M_1 \cup \tilde{M}_1$$

with Heegaard surface Σ .

REMARK 19.3. The fact that the resulting 3-manifold is *unique up to diffeomorphism* follows from Smale theorem recalled in Proposition 7.13, (1), $m = 3$.

On the other hand, every Heegaard splitting with Heegaard surface Σ gives rise to an encoding Heegaard diagram, possibly by handle sliding in order to reach the transversality requirement of the definition.

(*Heegaard diagram moves*) The elementary handle moves induce elementary moves on Heegaard diagrams which keep the resulting manifold M fixed up to diffeomorphism.

- Handle sliding produces the following diagram moves (called *H-diagram sliding*):
 - 1) of course we can modify C^\pm up to ambient isotopy (keeping that $C^+ \pitchfork C^-$);
 - 2) more substantially we have: let T_j^\pm and T_i^\pm be disjoint annular neighbourhoods of two circles of C^\pm as above. Connect these annuli by attaching an embedded 1-handle H at $\partial(T_j^\pm \amalg T_i^\pm)$ in such a way that apart the attaching segments, H is contained in $\Sigma \setminus \cup_{s=1}^g T_s^\pm$. The boundary of $T_j^\pm \cup T_i^\pm \cup H$ contains a component say c'_j which is the embedded connected sum of a parallel copy of c_j^\pm with a parallel copy of c_i^\pm . Then get a new C^\pm just by replacing c_j^\pm with c'_j .
- Cancellation/introduction of a pair of complementary handles produces the following diagram move. Consider the diagram

$$(S^1 \times S^1, c^- = S^1 \times \{y_0\}, c^+ = \{x_0\} \times S^1) .$$

Given any diagram (Σ, C^-, C^+) of genus g , replace Σ with $\Sigma \# (S^1 \times S^1)$ provided that the sum is performed at 2-disks disjoint from $C^- \cup C^+$ and $c^- \cup c^+$ respectively; then add to C^\pm the circle c^\pm to get the new diagram of genus $g + 1$. In terms of the resulting 3-manifolds we replace M with $M \# S^3 \sim M$. This move is called *elementary stabilization*.

The stabilization shows by the way that for every $g \geq g_H(M)$, M admits Heegaard splitting of genus g . In particular S^3 has splittings of every genus. One can prove (see [Sing]):

THEOREM 19.4. *Two Heegaard diagrams encode Heegaard splittings of a same 3-manifold M (considered up to diffeomorphism) if and only if they become equal up to finite sequences of H-diagram sliding or stabilizations.*

□

REMARK 19.5. Once the existence of Heegaard splitting has been easily established, several non trivial questions naturally arise such as:

- For a given M , estimate in effective terms its genus $g_H(M)$;
- For every $g \geq g_H(M)$, study the Heegaard splittings of M of genus g up to ambient isotopy.

Concerning the second question a complete answer is known for the 3-sphere and lens spaces defined above, that is for manifolds such that $g_H \leq 1$; we have:

For every $g \geq 1$, S^3 and every lens space have up to diffeotopy a unique Heegaard splitting of genus g .

On the other hand, for $g \geq 2$, there are manifolds with non isotopic splittings of genus g .

We refer to the body and the references of [BO] for more information about this question.

19.1.2. From Heegaard diagrams to spines and Δ -complexes. The aim of this section, mainly of technical nature, is to show other ways to present 3-manifolds derived from Heegaard splittings. We refer to [BP] for a wide treatment of the topic touched in this section. We will use some of this facts in Section 19.6.

Let (Σ, C^-, C^+) be a Heegaard diagram of M as above. Up to H -sliding, we can assume that not only $C^- \pitchfork C^+$, also that every component (called a *region*) of $\Sigma \setminus (C^- \cup C^+)$ is a open 2-disk. By following the reconstruction of the Heegaard splitting

$$M \sim M_1 \cup \tilde{M}_1$$

of M encoded by the diagram, we see that the core of every 2-handle attached to a circle c of $C^+ \times \{1\}$ can be extended by means of the annulus $c \times [0, 1]$ and we get an embedded 2-disk in \tilde{M}_1 which intersects transversely $\Sigma = \Sigma \times \{0\}$ at c . Do it for every c in C^+ and similarly for every c in C^- getting a disk in M_1 . Denote by \mathbf{P} the union of Σ with all such disks. \mathbf{P} is a kind of singular surface embedded into M with the following properties:

- (1) $S(\mathbf{P}) := (C^- \cup C^+) \subset \Sigma$ is the singular locus of \mathbf{P} ;
- (2) $V(\mathbf{P}) := C^- \cap C^+$ is the singular locus of $S(\mathbf{P})$, its points are the *vertices* of \mathbf{P} . The components, each diffeomorphic to the open 1-disk $(-1, 1)$, of $S(\mathbf{P}) \setminus V(\mathbf{P})$ are the *edges* of \mathbf{P} ; at every vertex there are four edge germs.
- (3) The components, each diffeomorphic to an open 2-disk, of $\mathbf{P} \setminus S(\mathbf{P})$ are the *regions* of \mathbf{P} . Along every edge there are three region germs. At every vertex there are six region germs.
- (4) If B^+ and B^- are the 0 and 3-handles of the splitting, then \mathbf{P} is a retract by deformation of

$$\hat{M} := M \setminus (\text{Int}(B^-) \cup \text{Int}(B^+)) .$$

In fact there is a *normal retraction* $r : \hat{M} \rightarrow \mathbf{P}$ such that: the fibre over a region point is diffeomorphic to $[-1, 1]$; the fibre over an edge point is a *tripode* that is the wedge of three segments $[0, 1]$ with common endpoint 0; the fibre over a vertex is a wedge of four such segments $[0, 1]$; \hat{M} can be reconstructed as being the mapping cylinder of such normal retraction.

We summarize all this by saying that \mathbf{P} is a *standard spine* of \hat{M} . By using the language of *CW-complexes*, \mathbf{P} is the 2-skeleton of such a complex over M which is obtained by attaching two 3-cells to it.

Now we give \mathbf{P} an additional structure called a *branching*. Give Σ , hence every region of \mathbf{P} contained in Σ , an orientation; give every circle c in $C^- \cup C^+$ an orientation, hence give the region of \mathbf{P} bounded by c the orientation with the prescribed boundary orientation. In this way $S(\mathbf{P})$ is union of oriented circles crossing transversely on Σ at some vertices; every region of \mathbf{P} is oriented in such a way there is a *prevailing orientation* induced on every edge of \mathbf{P} and this agrees with the one of the circle c in $S(\mathbf{P})$ which contains the edge. Notice that at every vertex the four configurations at the edge germs automatically match. We call this system of region orientations a *branching* \mathbf{b} of \mathbf{P} and we summarize by saying that the standard spine \mathbf{P} has been enhanced to be a *branched standard spine* (\mathbf{P}, \mathbf{b}) . The terminology is justified because the branching encodes a way to convert \mathbf{P} to be a (oriented) *branched surface* embedded in M . This means that \mathbf{P} can be moved in M in such a way that, although being singular, nevertheless it is well defined everywhere on \mathbf{P} a smooth field of oriented tangent 2-planes. In our specific situation, we can keep Σ fixed and isotopically move every other region R bounding

some circle c to becomes tangent to Σ along c over the side of c in Σ which carries together with R the prevailing boundary orientation.

The branched spine (\mathbf{P}, \mathbf{b}) can be considered as the 2-skeleton of the *dual cell decomposition* to a Δ -complex structure over M in the sense of [Hatch]. This is a kind of *triangulation* of M obtained as follows. Select one base point in each edge, region of \mathbf{P} and in the interior of the 3-balls B^\pm .

Recall that the standard j -simplex Δ^j is contained in the affine hyperplane $\{x_0 + x_1 + \dots + x_j = 1\}$ of \mathbb{R}^{j+1} and is the convex hull with ordered vertices of the vectors $e_0, e_1, e_2, \dots, e_j$ of the standard basis. Every h -face of Δ^j , $h = 0, 1, 2, \dots, j$, is the h -simplex with $h + 1$ vertices obtained by omitting $j + 1 - (h + 1)$ vertices of Δ^j . For every such a h -face F , there is a *canonical affine parametrization*

$$\phi_F : \Delta^h \rightarrow F$$

defined on the standard h -simplex and preserving the vertex ordering. A *singular j -simplex in M* is a continuous map $\sigma : \Delta^j \rightarrow M$. For every h -face F of Δ^j ,

$$(\Delta^h, \sigma \circ \phi_F)$$

is the corresponding *singular face* of the singular simplex.

Then we can associate to every $x \in V(\mathbf{P})$ a “dual” singular 3-simplex (Δ^3, σ_x) in such a way that the following properties are verified

- (1) For every x , the restriction of σ_x to the *interior* of every h -face of Δ , $h = 0, 1, 2, 3$, is a smooth embedding into M .
- (2) For every vertex x of \mathbf{P} , the image by σ_x of every vertex of Δ^3 is one of the base points of B^\pm ; x belongs to the image of the interior of Δ^3 ; the image of every open edge of Δ^3 is transverse to one dual region of \mathbf{P} which has x in its closure, exactly at the region base point; the image of every open 2-face of Δ^3 is trasverse to one edge of \mathbf{P} which has x in its closure, exactly at the edge base point.
- (3) Giving every image of an open edge of Δ^3 the orientation dual to the \mathbf{b} -orientation of the dual region, and the edge itself the orientation determined by the vertex order of Δ^3 , then the embedding of the open edge by σ_x is orientation preserving.
- (4) If the image of two singular open h -faces by some $\sigma_x, \sigma_{x'}$ (possibly $x = x'$) share the same dual $(3-h)$ -cell of \mathbf{P} , then the whole singular faces coincide.
- (5) Varying x in $V(\mathbf{P})$, the images of the several open h -faces form a *partition* of M .
- (6) Up to a piecewise smooth homeomorphism, M is obtained by gluing the abstract 3-simplices associated to the vertices of \mathbf{P} at common singular faces.

We can modify a branched standard spine (\mathbf{P}, \mathbf{b}) of \hat{M} , associated as above to a Heegaard diagram of M , to become a branched standard spine $(\mathbf{P}_0, \mathbf{b}_0)$ of M_0 , where M_0 is of the form

$$M_0 = M \setminus \text{Int}(B)$$

where B is some smooth 3-ball in M . So in particular \mathbf{P}_0 will be the 2-skeleton of a *CW-complex* over M with a unique 3-cell. Do it as follows. Take a point p on an edge of \mathbf{P} and locally insert an embedded triangle T , whose interior is contained in $M \setminus \mathbf{P}$, p is a vertex of T , T intersects transversely \mathbf{P} at two edges with p as common endpoint, contained respectively into germs of regions both inducing the prevailing orientation on the edge. Then T has a “free” edge l . Attach an embedded 1-handle with core parallel to l , intersecting transversely T along its b -tube at l , with attaching tube on \mathbf{P} . Then \mathbf{P}_0 results from \mathbf{P} by such a surgery. It is easy to see that the handle has fused the two components of $\partial \hat{M}$ into one spherical boundary component of a M_0 of the desired form. By construction \mathbf{P}_0 is a standard spine of

M_0 and it carries a branching \mathbf{b}_0 which agree with \mathbf{b} on the regions that have not be effected by the surgery. The above considerations apply to $(\mathbf{P}_0, \mathbf{b}_0)$ as well, so that we have a dual Δ -complex structure on M with only one singular 0-simplex.

We know that M is combable. Here we construct a nowhere vanishing tangent vector field by means of $(\mathbf{P}_0, \mathbf{b}_0)$. The tangent oriented 2-planes distribution along the branched surface \mathbf{P}_0 , has an orthogonal distribution of unitary tangent vector (with respect to an auxiliary riemann metric on M). This can be extended to a *generic traversing* unitary tangent vector field v_0 on M_0 . This means that the following properties hold:

- (1) Every integral line of v_0 is a segment with endpoints on ∂M_0 .
- (2) v_0 is simply tangent to ∂M_0 at the disjoint union \mathcal{S} of some smooth circles. For every $y \in \mathcal{S}$, the integral line passing through y is tangent to ∂M_0 and trasverse to \mathcal{S} .
- (3) Generic integral lines are not tangent to ∂M_0 ; generic tangent integral lines are tangent to ∂M_0 at one point; a finite number of exceptional integral lines is tangent at exactly two points.

We can assume that the image of every singular edge of the Δ -complex structure dual to $(\mathbf{P}_0, \mathbf{b}_0)$ intersects M_0 at the integral line of v_0 though the base point of dual region and that this line is not tangent to ∂M_0 .

We have

PROPOSITION 19.6. *v_0 extends to a unitary tangent vector field v defined on the whole of M .*

Proof : We can assume that B is in a chart of M and that the auxiliary metric looks standard in that coordinates. So the restriction of v_0 to $\partial M_0 \sim S^2$ is encoded by a map $h : S^2 \rightarrow S^2$ and can be extended over B if and only if its degree vanishes. Assume that M_0 is endowed with a framing (we will see later that this is always true), then the whole v_0 can be encoded by a map

$$H : M_0 \rightarrow S^2$$

which extends h . Usual invariance of the degree up to bordism shows that the degree of h vanishes indeed. □

19.1.3. Non orientable Heegaard splitting. If M is compact connected boundaryless and *non* orientable, then by using a nice handle decomposition as above we see that

$$M \sim M_1 \cup \tilde{M}_1$$

where M_1 is non orientable and is obtained by attaching say $h + 1$ disjoint 2-handles to the unique 0-handle at the boundary $\partial D^3 = S^2$ (and similarly for \tilde{M}_1 with respect to the dual decomposition). Up to handle sliding, we can assume that only one of these 2-handles destroyed the orientability and that $M_1 \sim \tilde{M}_1$ only depend (up to diffeomorphism) to the number $h + 1$. Let us call it a *non orientable handlebody of genus h* . The separating (non orientable) Heegaard surface is now diffeomorphic to

$$\tilde{\Sigma}_h := (\mathbf{P}^2(\mathbb{R}) \# \mathbf{P}^2(\mathbb{R})) \# h(S^1 \times S^1) .$$

The readear would imagine how to develop a non orientable version of Heegaard diagrams and diagram moves supported by such surfaces. Stabilization extends verbatim; a bit of care is necessary for the sliding diagram moves.

19.2. Surgery equivalence

We define a “surgery” equivalence relation on compact connected boundaryless 3-manifolds in terms of certain special 4-dimensional triads; the main application will be a characterization of 3-dimensional orientable boundary as the manifolds which are surgery equivalent to the sphere S^3 .

DEFINITION 19.7. Let M_0 and M_1 be compact connected boundaryless non empty 3-manifolds. We say that M_1 can be obtained by (*longitudinal*) *surgery (along a framed link)* of M_0 (and we write $M_1 \sim_\sigma M_0$) if there exists a 4-dimensional triads (W, M_0, M_1) which admits a handle decomposition \mathcal{H} consisting only of 2-handles attached simultaneously at disjoint attaching tubes.

To justify the terminology let us analyze the situation of the above definition. The decomposition is of the form

$$C_0 \cup (\cup_{j=1}^d H_j^2) \cup C_1$$

where $C_0 = M_0 \times [0, 1]$ and $C_1 = [-1, 0]$ are respective collars of M_0 and M_1 in W . The union of the embedded attaching spheres of the 2-handles

$$L = \cup_{j=1}^d K_s$$

is a so called *link* in $M_0 \sim M_0 \times \{1\}$. Every component K_s is a *knot* in M_0 . Moreover, we have a family of disjoint attaching tubes T_s each one equipped with a trivialization (also called a “framing”) by $S^1 \times D^2$, so that $K_s \sim S^1 \times \{0\}$. M_1 is obtained from M_0 by removing the interior of these attaching tubes and attaching back a copy of $D^2 \times S^1$ to every boundary component ∂T_s , in such a way that a meridian $S^1 \times \{x_0\}$ of $D^2 \times S^1$ is mapped onto a longitude $l_s \sim S^1 \times \{y_0\}$, $y_0 \in \partial D^2$ of K_s determined by the framing (such a longitude is unique up to isotopy).

This defines an equivalence relation; in particular $M_1 \sim_\sigma M_0$ implies $M_0 \sim_\sigma M_1$ because the dual decomposition of such an \mathcal{H} also consists of 2-handles only. If $M_0 \sim_\sigma M_1$, then M_0 is orientable if and only if M_1 is orientable and in such a case any special triad connecting them is necessarily orientable.

Let us restrict for a while to the orientable case. We have (see [Wa])

PROPOSITION 19.8. *Let M_0, M_1 be compact connected orientable boundaryless 3-manifold. Then $M_1 \sim_\sigma M_0$ if and only if there is an orientable 4-dimensional triad (W, M_0, M_1) ; that is for suitable orientations, $[M_0] = [M_1] \in \Omega_3$.*

COROLLARY 19.9. *$M \sim_\sigma S^3$ if and only if for every orientation of M , $[M] = 0 \in \Omega_3$.*

Proofs: Let us prove the corollary, assuming the proposition. If $M_1 \sim_\sigma S^3$, then by completing with one 4-handle attached at S^3 the dual \mathcal{H}^* of a special decomposition \mathcal{H} of a given triad (W, S^3, M) , we get a triad (V, M, \emptyset) so that $M = \partial V$. On the other way round, assume that $M = \partial V$ for some orientable connected 4-manifold V . Then the triad (V, \emptyset, M) admits an ordered handle decomposition with one 0-handle, and no 4-handles. By removing the 0-handle we get an orientable triad (W, S^3, M) and we conclude by applying to it the proposition.

Let us prove now the proposition. One implication is trivial. On the other hand, let us start with any orientable triad (W, M_0, M_1) . It has an ordered handle decomposition without both 0 and 4-handles. Moreover, we can assume that all handles of a given index are attached simultaneously at disjoint attaching tubes. The idea is to *trade* first every 1-handle for a 2-handle in such a way that the 4-manifold W possibly changes but its boundary is kept fixed. Every 1-handle does not destroy the orientability. Moreover, by the uniqueness of disks up to diffeotopy we can assume that all attaching tubes of the say d 1-handles are contained in a smooth 3-disk D in $M_0 \sim M_0 \times \{1\}$; then after having attached the 1-handles

to $C_0 = M_0 \times [0, 1]$ at $M_0 \sim M_0 \times \{1\}$, we get a 4-manifold W_1 such that ∂W_1 is the connected sum of M_0 with d copies of $S^2 \times S^1$. A 4-manifold V_1 with the same boundary can be obtained by surgery along a link L in M_0 formed by d unknotted and unlinked components contained in the above disk D , such that each component K_s is endowed with the framing associated to the distinguished longitude carried by a collar in a 2-disk D_s in D such that $\partial D_s = K_s$. The rest of the handle decomposition is unchanged and we get a 4-dimensional triad (W', M_0, M_1) having an ordered handle decomposition \mathcal{H}' without 0, 1 and 4-handles. In order to trade also the 3-handles for some 2-handles, we manage similarly by using the dual decomposition of \mathcal{H}' . Similarly as above we eventually get a triad (W'', M_1, M_0) with a handle decomposition \mathcal{H}'' consisting only of 2-handles. The proposition is proved. \square

Now we state two main theorems of this chapter.

THEOREM 19.10. (Lickorish-Wallace) *Every orientable connected compact boundaryless 3-manifold M is surgery equivalent to S^3 ($M \sim_\sigma S^3$).*

THEOREM 19.11. $\Omega_3 = 0$.

By Corollary 19.9 they can be considered as a corollary of each other. This actually happened. For example Lickorish proved Theorem 19.10 as an application of his main results about the generators of the mapping class groups of surfaces, and by the way he got a (new) proof that $\Omega_3 = 0$. On the contrary, Wallace obtained the result via the above Corollary 19.9, as it was already known (by several different proofs) that $\Omega_3 = 0$. We will develop diffusely this theme.

19.2.1. Non orientable surgery. There is a non orientable version of Corollary 19.9. Denote by \mathfrak{M} the non orientable 3-manifold which is the boundary of the non orientable 4-manifold \mathfrak{B} (unique up to diffeomorphism) with a handle decomposition consisting of one 0-handle and one 1-handle. In fact \mathfrak{M} is the non orientable total space of a fibration over S^1 with fibre S^2 . Then we have (the proof is similar to the orientable case):

PROPOSITION 19.12. *Let M be a compact connected boundaryless non orientable 3-manifold. Then $M \sim_\sigma \mathfrak{M}$ if and only if $[M] = 0 \in \eta_3$.*

\square

19.3. Proofs of $\Omega_3 = 0$

In this section we discuss a few “direct” proofs of Theorem 19.11, so that Theorem 19.10 will result as a corollary.

- (Via immersions in \mathbb{R}^5 and Seifert’s surfaces) This is the first proof of $\Omega_3 = 0$ (Rohlin 1950, see his papers translated in [GM]). If a compact connected orientable boundaryless 3-manifold \hat{M} is embedded in \mathbb{R}^5 , then by Proposition 13.7 it admits an orientable Seifert’s surface W so that in particular $\hat{M} = \partial W$.

REMARK 19.13. Rohlin used a different argument to show the existence of Seifert’s surfaces based on the extension of a combinatorial method due to Kneser to desingularize embedded simplicial cycles in triangulated manifolds to the codimension 2 oriented and relative case (see [GM] for an exhaustive discussion of this point).

In order to prove the theorem it is enough to show that for every orientable M there is an orientable triad (V, M, \hat{M}) such that \hat{M} is embedded into \mathbb{R}^5 . It was known since [Whit3] (1944) (recall Section 7.8) that for every such an M there is a generic immersion $f : M \rightarrow \mathbb{R}^5$; this also follows from Smale-Hirsch immersion

theory because we will see in Section 19.6 that M is parallelizable. We can conclude by applying the “embedding up to surgery” of Section 7.9.

- (*Via vanishing of characteristic numbers*) In a sense the most “modern” proof (being a special case of a general determination of bordism groups based on Thom’s spaces and characteristic numbers) is the one obtained by applying Proposition 16.8, as we will see in Section 19.6 that orientable 3-manifolds are parallelizable.

19.4. Proofs of Lickorish-Wallace theorem

In this section we discuss a few “direct” proofs of Theorem 19.10, so that Theorem 19.11 will result as a corollary.

These proofs are based on Heegaard splittings.

(*Via Dehn twists*) This is original Lickorish’s proof [Lick]. A main Lickorish result establishes a distinguished set of generators of the mapping class group $\text{Mod}(\Sigma_g)$. Let C be a smooth circle on the surface Σ_g . Assume that C is *essential* that is it is not the boundary of a smooth disk embedded into Σ_g . Fix an auxiliary trivialization

$$\psi : S^1 \times [-1, 2] \rightarrow U$$

of a tubular neighbourhood of C . Give $S^1 \times [-1, 2]$ the coordinates $(e^{i\theta}, t)$, $\theta \in [0, 2\pi]$. Let $\rho : [-1, 2] \rightarrow [0, 1]$ be a smooth non decreasing function such that the restriction to $[0, 1]$ is a diffeomorphism onto the image, it is constantly equal to 0 on $[-1, 0]$, constantly equal to 1 on $[1, 2]$. Then define the diffeomorphism

$$\tau_C : \Sigma_g \rightarrow \Sigma_g$$

which is the identity outside U , and is defined on U as $\psi \circ h \circ \psi^{-1}$, where

$$h(e^{i\theta}, t) = (e^{i(\theta+2\pi\rho(t))}, t) .$$

τ_C and τ_C^{-1} are called Dehn’s twists along C . Their classes in $\text{Mod}(\Sigma_g)$ do not depend on the arbitrary choices we made, including the fact that C is considered up to ambient isotopy. Let us call Dehn’s twists also these classes. Then we have:

THEOREM 19.14. *$\text{Mod}(\Sigma_g)$ is generated by the Dehn twists along essential smooth circles.*

□

In fact the result is more precise because it shows that a determined finite set of twists suffices. Anyway, we assume this theorem and we show how to deduce that $M \sim_\sigma S^3$.

LEMMA 19.15. *Let $[\psi] = [\tau_k] \circ \dots \circ [\tau_1]$ be an element of $\text{Mod}(\Sigma_g)$ expressed as composition of k Dehn’s twists. Then there exist two systems of k disjoint solid tori V_1, \dots, V_k and V'_1, \dots, V'_k in the interior of the handlebody \mathfrak{H}_g such that ψ extends to a diffeomorphism*

$$\bar{\psi} : \mathfrak{H}_g \setminus \cup_j \text{Int}(V_j) \rightarrow \mathfrak{H}_g \setminus \cup_j \text{Int}(V'_j) .$$

Proof : If $k = 0$, then ψ is isotopic to the identity and the statement is trivially verified. Assume that $k = 1$, $\psi = \tau = \tau_C^{\pm 1}$. Consider a collar $C(\Sigma_g) \sim \Sigma_g \times [0, 1]$ of $\Sigma_g = \partial\mathfrak{H}_g$ in \mathfrak{H}_g . Set $V \sim U(C) \times [1/2, 1] \subset C(\Sigma)$ (up to corner smoothing) where $U(C)$ is an annular neighbourhood of C in Σ_g . Set $V' = V$. Then an extension of τ is obtained by taking a parallel copy of τ on every leaf $U(C) \times \{s\}$, $0 \leq s \leq 1/2$, and setting $\bar{\tau}$ equal to the identity on the remaining part of $\mathfrak{H}_1 \setminus \text{Int}(V)$. If $k = 2$ we can extend τ_2 along C_2 by the same method, provided that the “tunnel” V_2 is more deeply in the interior of \mathfrak{H}_g so that $V_1 \cap V_2 = \emptyset$ and $\bar{\tau}_1 = \text{id}$ along V_2 . Then set $V'_2 = V_2$, $V'_1 = \bar{\tau}_2(V_1)$, so that $\bar{\tau}_2 \circ \bar{\tau}_1$ is a desired extension of ψ . By iterating the same method, by induction we get the result for every $k \geq 0$.

□

Consider any genus g Heegaard splitting presented as above in the form

$$M \sim \mathfrak{H}_g \amalg_{[\phi]} \mathfrak{H}_g, \quad [\phi] \in \text{Mod}(\Sigma_g) .$$

We know that also S^3 admits a genus g splitting say

$$S^3 = \mathfrak{H}_g \amalg_{[\phi']} \mathfrak{H}_g .$$

Set $\psi = \phi^{-1} \circ \phi' = (\phi^{-1} \circ \gamma^{-1}) \circ (\gamma \circ \phi')$. Apply the above lemma to ψ . Then we get an extension

$$\bar{\psi} : \mathfrak{H}_g \setminus \cup_j \text{Int}(V_j) \rightarrow \mathfrak{H}_g \setminus \cup_j \text{Int}(V'_j)$$

which by construction extends to a diffeomorphism

$$\bar{\psi} : S^3 \setminus \cup_j \text{Int}(V_j) \rightarrow M \setminus \cup_j \text{Int}(V'_j)$$

and this readily shows that $M \sim_{\sigma} S^3$. □

(By induction on a Heegaard diagram complexity) Last but not least, we present the clever proof of [Rourke]. Let us fix an orientation of M ; it is understood that all manifolds produced by the following construction are oriented and that the orientations are compatible. Actually we are going to realize that $S^3 \sim_{\sigma} M$.

LEMMA 19.16. *If $M = M_1 \# M_2$ and $S^3 \sim_{\sigma} M_j$, $j = 1, 2$, then $S^3 \sim_{\sigma} M$.*

Proof : As $S^3 = S^3 \# S^3$, the lemma follows immediately. □

We write

$$M = M(x, y)$$

to mean that M is encoded by a genus g Heegaard diagram (Σ, x, y) where $x = \{x_1, \dots, x_g\}$, $y = \{y_1, \dots, y_g\}$ are the two non dividing families of simple smooth circles on the surface Σ early denoted by C^- and C^+ respectively. Recall that $x \pitchfork y$.

Let $z = \{z_1, \dots, z_g\}$ be another family of g smooth circles on Σ which does not divide the surface. Assume that $z \pitchfork x$ and $z \pitchfork y$. Recalling the reconstruction of $M = M(x, y)$ from the diagram, we can assume that z is traced on the Heegaard surface $\Sigma \sim \Sigma \times \{0\}$. Give an orientation every z_j , fix a system of disjoint tubular neighbourhoods U_j of every z_j in M such that $\partial U_j \pitchfork \Sigma$ along a pair of curves parallel to z_j , and select the longitude $l_j \subset \partial U_j$ given by the component of $\partial U_j \cap \Sigma$ whose orientation is parallel to the one of z_j . For every j , up to isotopy there is a unique framing $\rho_j : S^1 \times D^2 \rightarrow U_j$ so that the longitude l_j is carried by ρ_j ; thus we have determined a framed link $L := \cup_j (z_j, l_j)$ in $M = M(x, y)$. These trivializations are used as attaching maps of disjoint 2-handles so that we have constructed a special triad

$$(W, M, \tilde{M}), \quad \tilde{M} \sim_{\sigma} M .$$

The following simple lemma, which is in fact the core of the proof, establishes a key relationship between surgery equivalence and Heegaard splitting. In the situation depicted so far we have

LEMMA 19.17. $\tilde{M} \sim M(x, z) \# M(z, y)$.

Proof : Denote by $M_0(x, z)$ the manifold with spherical boundary obtained by removing from $M(x, z)$ the interior of a smooth embedded 3-disk. Similarly for $M_0(z, y)$. It follows straightforwardly by comparing the reconstruction of $M(x, z)$ and $M(z, y)$ from the diagrams and the construction of \tilde{M} by surgery on M along the framed link $L := \cup_j (z_j, l_j)$ that, up to diffeomorphism, \tilde{M} is obtained by gluing $M_0(x, z)$ and $M_0(z, y)$ by a diffeomorphism between the boundaries. With the terminology of Section 7.5.2, \tilde{M} is a weak connected sum of $M(x, z)$ and $M(z, y)$. Then by Smale theorem (Proposition 7.13, (1), $m = 3$) it is a true connected sum.

□

The last ingredient is a suitable *measure of the complexity of the Heegaard diagrams*. Let (Σ, x, y) be such a diagram of genus g . Recall that every $x_i \cap y_j$ is a finite set and denote by $|x_i \cap y_j|$ the number of elements (we stress that it is the “geometric” number, no algebraic intersection numbers are involved). Then set

$$c(\Sigma M, x, y) := (g, r := \min_{i,j} |x_i \cap y_j|) \in \mathbb{N}^2$$

where \mathbb{N}^2 is endowed with the lexicographic order. We will achieve the result by (double) induction on the complexity c of a given splitting of M .

The initial step is when $g = 0$; in such a case by the very definition M is a twisted 3-sphere, so it is a true smooth sphere again by Smale theorem (Proposition 7.13, (2), $m = 3$); the empty surgery does the job.

Let $M = M(x, y)$ of complexity $c = (g, r)$ and assume that $S^3 \sim_\sigma M'$ for every M' admitting an encoding diagram of complexity $c' = (g', r') < c = (g, r)$.

If $c = (g, 1)$, then the given diagram is a stabilization of a diagram of genus $g - 1$, hence $S^3 \sim_\sigma M$ by the inductive hypothesis.

If $c = (g, 0)$, it is not restrictive to assume that $x_1 \cap y_1 = \emptyset$.

Claim 1. *There exists a non separating circle z_1 on Σ which intersects each of x_1 and y_1 transversely at a single point.*

Assuming this fact, extend z_1 to a non dividing family z of g circles on Σ , $z \pitchfork x$ and $z \pitchfork y$. Then both $M(x, z)$ and $M(z, y)$ have encoding diagrams with $r = 1$ and we conclude by applying the previous case and Lemmas 19.16, 19.17.

Assume that $r > 1$. It is not restrictive to assume that $r = |x_1 \cap y_1|$.

Claim 2. *There exists a non separating circle z_1 on Σ which intersects each of x_1 and y_1 transversely at a number of points strictly less than r .*

Assuming this fact, extend z_1 to a non dividing family z of g circles on Σ , $z \pitchfork x$ and $z \pitchfork y$. Then both $M(x, z)$ and $M(z, y)$ have encoding diagrams of the same genus g but with strictly smaller complexity anyway. Then by the inductive hypothesis S^3 is surgery equivalent to both and again we can conclude by applying Lemmas 19.16 and 19.17.

It remains to prove the two claims. As for Claim 1, there are two possibilities, either $\Sigma' := \Sigma \setminus (x_1 \cup y_1)$ is connected or non connected. Take a small segment γ in Σ tranverse to x_1 at one point, with endpoints p_0, p_1 ; similarly let γ' be tranverse to y_1 at one point, with endpoints p'_0, p'_1 . If Σ' is not connected, up to reordering, we can assume that the couples of endpoints p_0, p'_0 and p_1, p'_1 belong to different connected components. Then in both cases a smooth circle z_1 in Σ with the required properties can be obtained of the form

$$z_1 = \gamma \cup \alpha \cup \gamma' \cup \alpha'$$

where α is a smooth arc which connects p_0 and p'_0 , while α' is such an arc connecting p_1 and p'_1 .

As for Claim 2, let A and B two points of $x_1 \cap y_1$ which are adjacent in x_1 . Then there is an arc α in x_1 which intersects y_1 only at its endpoints A and B . These points also divide y_1 in two arcs β and γ . As y_1 does not separate Σ , there is at least one of these arcs, say β , such that $\alpha \cup \beta$ does not separates Σ . Then we can construct z_1 made by a parallel copy α' of α which near A is in the direction of β , completed by a segment β' close to β . One realizes that z_1 intersects x_1 in at most $r - 1$ points and intersects y_1 in at most one point. So z_1 has the desired properties. This proof of Theorem 19.10 is now complete.

□

19.4.1. On Kirby’s calculus. We have proved that for every orientable compact, connected, boundaryless 3-manifold M there is a special triad (W, S^3, M) which realizes the surgery equivalence $S^3 \sim_\sigma M$, so that W admits an ordered handle decompositions consisting only of 2-handles. Every such a handle decomposition with say k handles is encoded by a framed link L in S^3 with k constituent knot K_j , $j = 1, \dots, k$. For every K_j , its framing is encoded by a parallel longitude l_j ; fixing an auxiliary parallel orientation of both K_j and l_j , this last is encoded by the linking number $L(K_j, l_j)$, that is, equivalently, by the intersection number of l_j with any oriented Seifert surface of K_j in S^3 . The natural question is how two such framed links are related two each other. Certainly a given handle decomposition can be modified by handle sliding and this can be translated in terms of the corresponding framed links. Moreover we must consider the possibility of modifying the special triad without changing its boundary. A distinguished way to do it consists in attaching a 2-handle with attaching circle contained and unknotted in a 3-ball disjoint from the other link components, and with framing equal to ± 1 . One realizes that this does not modify the boundary while we pass from W to $W \# \pm \mathbf{P}^2(\mathbb{C})$. This is called an *elementary blow-up move*. We can consider also the inverse (negative) move of removing such a handle. An important Kirby’s result [Kirby2] can be formulated, somewhat qualitatively, as follows.

THEOREM 19.18. *Two framed link L_1 and L_2 in S^3 encode a realization of $S^3 \sim_\sigma M$ if and only if they are related to each other by a finite sequence of modifications which either translate 2-handle sliding or are positive/negative elementary blow-up moves.*

The proof is rather demanding and is based on Cerf’s theory [Ce2]. After such a qualitative statemet, successive efforts have been devoted to convert it into an efficient diagrammatic calculus on framed links in S^3 . Kirby himself found a generator (called “band move”) for the handle sliding; this is *not a ‘local’ move*, and resembles a move described above on Heegaard diagrams. Later in [FR] one points out an *infinite* family of *local* moves generating the whole calculus. Finally in [Mart2] one has determined a generating *finite* family of *local* moves.

19.5. On $\eta_3 = 0$.

Referring to Section 19.2.1, the following two theorems can be obtained as a corollary of each other.

THEOREM 19.19. *Every non orientable compact connected boundaryless 3-manifold M is surgery equivalent to \mathfrak{M} ($M \sim_\sigma \mathfrak{M}$).*

THEOREM 19.20. $\eta_3 = 0$.

19.5.1. On some proofs of $\eta_3 = 0$. In the spirit of the above discussion about $\Omega_3 = 0$, we give here a few indication about “direct” proofs of Theorem 19.20. Certainly it is contained in the general statement of Thom’s Theorem 17.20 and in a sense this is the first proof of this result. However, Rohlin claimed, without further explanation (see [GM]), that the method he had used to prove $\Omega_3 = 0$ allows to prove the same in the non orientable case. This is not so immediate. Starting from a general immersion of M (non orientable) in \mathbb{R}^5 , the “embedding up to bordism” works as well and we can assume that M is actually embedded into \mathbb{R}^5 . However, (recall Remark 13.11), if a tubular neighbourhood U of M in \mathbb{R}^5 is associated to a splitting $T(M) \oplus \xi$ of the restriction of $T(\mathbb{R}^5)$ to M , we cannot assume in general that ξ has a nowhere vanishing section and hence we cannot assume that there is a possibly non orientable Seifert surface. To conclude it would be enough to find M' embedded in some 5-manifold X such that $[M] = [M'] \in \eta_3$, $[M'] = 0 \in \mathcal{H}^2(X, \mathbb{Z}/2\mathbb{Z})$, and there is a splitting $T(M) \oplus \xi'$ of the restriction of

$T(X)$ to M' such that ξ' has a nowhere vanishing section. This can be achieved as follows (see also the suggestion at pag. 91 of [GM]). Let M embedded in \mathbb{R}^5 be as above. Consider the Euler class of ξ belonging to $\eta_1(M)$. This is represented by smooth circle C on M . Take the blow up say X of \mathbb{R}^5 along C (see Section 7.10); let M' be the blow up of M along C which is embedded into X as the strict transform of M . One can check that $M' \subset X$ verify the required properties. In particular $[M'] = [M] + [S^1 \times \mathbf{P}^2(\mathbb{R})] = [M] \in \eta_3$.

19.5.2. On some proofs that $M \sim_\sigma \mathfrak{M}$. Lickorish extended in [Lick2] his main result on the generators of the mapping class groups to non orientable surfaces. This allows him to extend also the proof about the surgery equivalence to the non orientable case.

In [AG] the simpler clever proof of [Rourke] has been extended to the non orientable case.

19.6. Combing and framing

A main result of this section will be that every compact connected orientable boundaryless 3-manifold M is *parallelizable*. Current modern proofs of this primary result in 3-dimensional differential topology (originally attributed to Stiefel [Sti]) use either a mixture of *spin structures* and of *Stiefel Whitney classes* theory (see for instance [Ge], Section 4.2), or a refinement due to Kaplan [Ka] of Lickorish-Wallace theorem by means of the so called *Kirby calculus* (see also [FM], Section 9.4.). We do not dispose of this artillery. Nevertheless, by following [BL] we will provide two self-contained elementary proofs, revealing by the way different aspects of the question. The first proof uses some ideas of the last mentioned approach, however it avoids the use of both Lickorish-Wallace Theorem and Kirby calculus. The second proof will result from a parallel discussion about combing and framing 3-manifolds. We will also provide a classification of combings with respect to a given auxiliary reference framing.

From now on M will denote a compact connected orientable boundaryless 3-manifold. Alike every odd dimensional manifold, M is combable, then it carries nowhere vanishing tangent vector fields v . These are considered up to smooth homotopy through such fields and called *combing*s of M . We will systematically confuse a homotopy class with suitable representatives. As we know, a *framing* \mathcal{F} of $T(M)$ is a triple (v, w, z) of pointwise linearly independent tangent vector fields. Also framings are considered up to homotopy; the three components of \mathcal{F} determine a same combing of M . Fixing any auxiliary riemannian metric g on M , we can assume that a given combing is (represented by) an unitary field with respect to g , and every framing is represented by pointwise orthonormal fields. A framing, if any, determines also an orientation of M (so that orientability of M is a necessary condition). If M is *oriented* and parallelizable, then there are framings which induce the given orientation. From now on we will assume that M is *oriented*, by fixing an auxiliary orientation.

19.6.1. Framing via even surgery. The first remark is that it is enough to prove that M is almost-parallelizable. A *quasi-framing* of M is a framing of $T(M)$ over a submanifold of the form

$$M_0 := M \setminus \text{Int}(B)$$

where B is a smooth 3-disk in M . We say that M is *almost-parallelizable* if admits a quasi-framing. In such a case, by the uniqueness of the disk up to ambient isotopy, we see that the choice of the disk B is immaterial. We have

LEMMA 19.21. *M is parallelizable if and only if it is almost-parallelizable.*

Proof : An implication is trivial. As for the other implication, we can assume that B is contained in a chart of M and looks standard therein as well as the auxiliary metric. Then the restriction of a quasi-framing \mathcal{F}' to $\partial B = S^2$ is encoded by a map

$$\rho : S^2 \rightarrow SO(3) .$$

We know that $SO(3) \sim \mathbf{P}^3(\mathbb{R})$ (Example 6.5), with S^3 as universal covering space, hence $\pi_2(SO(3)) \sim \pi_2(S^3) = 0$. It follows that ρ extends to $\hat{\beta} : B \rightarrow SO(3)$, and that \mathcal{F}' extends to a framing \mathcal{F} of the whole $T(M)$. □

Let M be obtained by longitudinal surgery along a framed link L in S^3 ; we write

$$M = \chi(S^3, L) .$$

M is the final boundary of a triad $(W, \emptyset, \chi(S^3, L))$ where W is obtained by attaching disjoint 2-handles to D^4 at $S^3 = \partial D^4$. Every 2-handle $D^2 \times D^2$ determines a constituent knot K of L , so that $\partial D^2 \times D^2 \sim N(K)$, $N(K)$ being a tubular neighbourhood of K in S^3 , $\partial D^2 \times \{0\}$ being identified with a longitude l_K on $\partial N(K)$ along K . The framing of every component K of L is encoded by the linking number $n_K \in \mathbb{Z}$ between K and the longitude l_K , where K and l_K are co-oriented in such a way that the projection of L_K onto K is of degree 1. We say that the surgery is *even* if for every constituent knot K of L , $n_K \in 2\mathbb{Z}$. We have

PROPOSITION 19.22. *Let (W, \emptyset, M) be the triad associated to an even surgery $M = \chi(S^3, L)$. Then W is parallelizable.*

Proof : To simplify the notation, we give the proof for a one-component link but this generalizes straightforwardly. So let $L = (K, n)$, $n \in 2\mathbb{Z}$. Both D^4 and $D^2 \times D^2$ are parallelizable, so we have to show that they carry some framings which match on $N(K)$. Fix a reference framing \mathcal{F}_0 on D^4 ; the restriction to $N(K)$ of any framing \mathcal{F} on the 2-handle is encoded by a map $\rho : N(K) \rightarrow SO(4)$. Viewing S^3 as the group of unit quaternions one can construct a 2-fold covering map $S^3 \times S^3 \rightarrow SO(4)$ showing that $\pi_1(SO(4)) = \mathbb{Z}/2\mathbb{Z}$ (see Example 6.5). As the solid torus $N(K)$ retracts to $K \sim S^1$, ρ determines an element of $\mathbb{Z}/2\mathbb{Z}$, and the two framings coincide on $N(K)$ if and only if this is equal to 0. It can be readily seen that this element is equal to the number $n \bmod (2)$. □

COROLLARY 19.23. *Let $M = \chi(S^3, L)$ be an even surgery. Then M is stably-parallelizable (i.e. $T(M) \oplus \epsilon^1$ is a product bundle).*

Proof : Let $(W, \emptyset, \chi(S^3, L))$ be as above. Then $T(W)_M = T(M) \oplus \nu$ where ν is a trivial normal line bundle of $M = \partial W$ in W . We know by the proposition that $T(W)$ is a product bundle. □

LEMMA 19.24. *If M is stably parallelizable then it is almost-parallelizable.*

Proof : As $T(M) \oplus \epsilon^1 = M \times \mathbb{R}^4$, every $T_x M$ is an oriented 3-plane in \mathbb{R}^4 . So we have a smooth classifying map $\rho : M \rightarrow S^3$ where the sphere is considered as the space of oriented 3-planes in \mathbb{R}^4 , and $T(M)$ is the pull back of the corresponding tautological bundle (see Chapter 6). Now we know that M_0 retracts onto a 2-dimensional spine \mathbf{P}_0 as in Section 19.1.2. Hence the restriction of ρ to \mathbf{P}_0 is not surjective, then it is homotopic to a constant map, the restriction of TM to \mathbf{P}_0 whence to M_0 is a product bundle. □

REMARK 19.25. Lemma 19.24 holds in every dimension n ; the key point is that $M \setminus \text{Int}(B^n)$ has the homotopy type of a CW-complex of dimension less or equal $n - 1$ (see Section 9.3.1).

Recall the notion of weak connected sum given in Section 7.5.2. We know by Smale theorem that 3-dimensional weak connected sums are veritable connected sums, but we do not need this fact in the present discussion. The following lemma is trivial.

LEMMA 19.26. *If there exists M' such that a weak connected sum of M and M' is parallelizable, then M is almost parallelizable.*

□

A Heegaard splitting (of some genus g) of M can be encoded by a non dividing family say L of g smooth circles on the boundary $\partial\mathfrak{H}_g$ of an handlebody \mathfrak{H}_g . We can assume that \mathfrak{H}_g is embedded in a standard way in S^3 so that $\mathfrak{H}'_g := \overline{S^3 \setminus \mathfrak{H}_g}$ is also a handlebody of genus g , and we have a Heegaard splitting of S^3 . Give every component K of L the framing carried by a tubular neighbourhood of K in $\partial\mathfrak{H}_g$. Then we have a framed link L in S^3 . By applying the proof of Lemma 19.17 we readily have

LEMMA 19.27. *$\chi(S^3, L)$ is a weak connected sum of M and M' , for some M' .*

□

So, by combining the above lemmas, in order to show that M is almost parallelizable (hence parallelizable) it is enough to show that we can implement the above construction in such a way that the surgery $\chi(S^3, L)$ is even. Fix any embedding $L \subset \partial\mathfrak{H}_g \subset \mathfrak{H}_g \subset S^3$ as above. Fix a system $\mu = \{m_1, \dots, m_g\}$ of g meridians on $\partial\mathfrak{H}_g$ (which bound 2-disks properly embedded in \mathfrak{H}_g) and a dual system of g meridians $\lambda = \{l_1, \dots, l_g\}$ for the complementary handlebody \mathfrak{H}'_g . A Dehn twist on $\partial\mathfrak{H}_g$ along a curve m_i extends to a diffeomorphism of the whole \mathfrak{H}_g . Hence we can modify the family L by applying any finite sequence of such Dehn twists, keeping the fact that $\chi(S^3, L)$ is a weak connected sum of M and M' , for some M' . We are reduced to prove the following lemma.

LEMMA 19.28. *Up to a suitable finite sequence of Dehn twists along the meridians in μ , $\chi(S^3, L)$ is an even surgery.*

Proof : The question can be reduced to $\mathbb{Z}/2\mathbb{Z}$ -linear algebra on $\eta_1(\partial\mathfrak{H}_g)$. Start with any surgery $\chi(S^3, L) = M \# M'$ as above. The union of curves in the families μ and λ form a symplectic basis of $\eta_1(\partial\mathfrak{H}_g)$ with respect to the intersection form. So, by confusing classes mod (2) and representatives and setting $L = \{K_1, \dots, K_g\}$, we have the $\mathbb{Z}/2\mathbb{Z}$ -linear combinations:

$$K_j = \sum_{i=1}^g (a_i^j m_i + b_i^j l_i) .$$

The framing mod (2) of K_j is given by

$$n_j = \sum_i a_i^j b_i^j \in \mathbb{Z}/2\mathbb{Z} .$$

A Dehn twist T_j along m_i acts on $\eta_1(\partial\mathfrak{H}_g)$ so that

$$T_i(l_i) = l_i + m_i$$

while it is the identity on the other $2g - 1$ elements of the given basis. All intersection numbers mod (2) of the curves of L vanish, that is

$$K_r \bullet K_s = 0, \quad r, s = 0, \dots, g .$$

This means that the coefficients of the above linear combinations verify the system of conditions:

$$(19.1) \quad \sum_{i=1}^g (a_i^r b_i^s + a_i^s b_i^r) = 0, \quad r, s = 0, \dots, g.$$

We allow ourselves to apply twist combinations of the form $T_1^{x_1} \dots T_g^{x_g}$. Then we want to show that the $\mathbb{Z}/2\mathbb{Z}$ -linear non homogeneous system

$$(19.2) \quad \sum_{i=1}^g (x_i + b_i^r) a_i^r = 0, \quad r = 1, \dots, g.$$

admits a solution in $(\mathbb{Z}/2\mathbb{Z})^g$. Note that we tacitly use several times that $z = z^2$ for every $z \in \mathbb{Z}/2\mathbb{Z}$. If for every r all $a_i^r = 0$, then every (x_1, \dots, x_g) is a solution. Otherwise we can assume that $a_1^1 = 1$. Then the solution of the equation

$$\sum_{i=1}^g (x_i + b_i^1) a_i^1 = 0$$

are of the form $x_1 = \sum_{j=2}^g c_j x_j$. By replacing in the other equations and using the relations 19.1, we are reduced to solve a system in x_2, \dots, x_g of the same form

$$\sum_{i=2}^g (x_i + \tilde{b}_i^r) \tilde{a}_i^r = 0, \quad r = 2, \dots, g$$

with

$$\tilde{a}_i^r = a_1^r a_i^1 + a_i^r, \quad \tilde{b}_i^r = a_1^r b_i^1 + b_1^r.$$

One verifies directly that these new coefficients formally satisfy the corresponding conditions 19.1. So we can conclude by recurrence. \square

REMARK 19.29. It is proved in [Ka], see also [FM], that for every M as above there is an even surgery $M = \chi(S^3, L)$. Starting from any surgery presentation of M with associated triad (W, \emptyset, M) (which exists by Lickorish-Wallace Theorem), the proof consists in an algorithm which modifies the triad to some (W', \emptyset, M) associated to an even surgery. More precisely, by using some notions that we will define in Chapter 20, one proves first that every L contains a so called *characteristic sub-link* and that the surgery is even if a characteristic sub-link is empty. Then the algorithm reduces progressively the number of components of a characteristic sub-link by means of certain moves on the handle decompositions (organized in an efficient so called ‘Kirby calculus’) which may change the 4-manifold W by keeping the triad boundary fixed. Note that this proof does *not* use the harder fact that Kirby calculus connects any two surgery presentations of M [Kirby2].

Our first proof that M is parallelizable is now complete. \square

Next we will elaborate on the second proof.

19.6.2. On the cobordism ring of an orientable 3-manifold. We specialize the results of Chapters 13. In the present situation the relevant co-bordism modules are

$$\mathcal{H}^j(M; \mathbb{Z}/2\mathbb{Z}), \quad \mathcal{H}^j(M; \mathbb{Z}), \quad j = 0, 1, 2, 3.$$

We summarize here some properties which we will use.

- $\mathcal{H}^3(M; \mathbb{Z}/2\mathbb{Z}) \sim \mathcal{H}^0(M; \mathbb{Z}/2\mathbb{Z}) \sim \mathbb{Z}/2\mathbb{Z}$ by the isomorphism which associates the usual generator of $\mathcal{H}^3(M; \mathbb{Z}/2\mathbb{Z})$ to the fundamental class mod (2) $[M]$; similarly over \mathbb{Z} .

- $\mathcal{H}^2(M; \mathbb{Z}/2\mathbb{Z}) = \eta^2(M) = \eta_1(M)$
 - $\mathcal{H}^2(M; \mathbb{Z}/2\mathbb{Z}) \sim \mathcal{H}^1(M; \mathbb{Z}/2\mathbb{Z})$ in a natural way: if $\alpha = [F] \in \mathcal{H}^1(M; \mathbb{Z}/2\mathbb{Z})$ we can assume that the embedded surface $F \subset M$ is connected and does not divide M if $\alpha \neq 0$. If γ is a smooth simple arc in M trasverse to F at one point, it can be completed to a smooth circle c by means of an arc γ' contained in $M \setminus F$ so that $[F] \sqcup [c] = 1$. Viceversa, if $[c] \neq 0 \in \mathcal{H}^2(M; \mathbb{Z}/2\mathbb{Z})$, then it is part of a basis \mathcal{B} of $\mathcal{H}^2(M; \mathbb{Z}/2\mathbb{Z})$ which is finite dimensional. The functional $[c]^*$ belonging to the dual basis composed with the natural homomorphism $\pi_1(M) \rightarrow \eta_1(M)$ defines a $\mathbb{Z}/2\mathbb{Z}$ -valued representation of the fundamental group that can be realized by a connected hypersurface F , so that in particular $[F] \sqcup [c] = 1$. Moreover we can assume that F intersects transversely c at one point: if F intersects c at an odd number of points, we can reduce them to one by attaching suitable embedded 1-handles along c and performing surgeries of F .

- If c is a connected oriented smooth circle in M such that $[c] = 0 \in \mathcal{H}^2(M; \mathbb{Z})$ then there is an oriented Seifert surface for c in M ; if $[c] = 0 \in \mathcal{H}^2(M; \mathbb{Z}/2\mathbb{Z})$ then there is a possibly non orientable Seifert surface for c in M ;

- Consider the natural forgetting morphism $\mathcal{H}^2(M; \mathbb{Z}) \rightarrow \mathcal{H}^2(M; \mathbb{Z}/2\mathbb{Z})$. We have

LEMMA 19.30. *A class $\alpha \in \mathcal{H}^2(M; \mathbb{Z})$ belongs to the kernel of the forgetting morphism $\mathcal{H}^2(M; \mathbb{Z}) \rightarrow \mathcal{H}^2(M; \mathbb{Z}/2\mathbb{Z})$ if and only if α is an even class that is there is $\beta \in \mathcal{H}^2(M; \mathbb{Z})$ such that $\alpha = 2\beta$.*

Proof : We can assume that α is represented by a connected oriented smooth circle c . By hypothesis c is the boundary of a possibly non orientable connected compact surface F embedded in M . If F is orientable, then $\alpha = 0$ and we have done. If F is not orientable, it follows from the classification of surfaces that there is a smooth 1-submanifold C on $\text{Int}(F)$ such that a tubular neighbourhood $U(C)$ of C in F is union of Möbius strips, and $F \setminus C$ is orientable. Then orient $F \setminus C$ in such a way the oriented c inherits the boundary orientation, and orient consequently $C' := \partial U(C) \subset F \setminus \text{Int}(U(C))$. Then $[c] = [C'] \in \mathcal{H}^2(M; \mathbb{Z})$ and $[C'] = 2[C'']$ where C'' is the union of the cores of $U(C)$ oriented in such a way that the restriction of the projection of C' onto every core is of positive degree. □

19.6.3. Combing and orthogonal plane distributions. Let v be a combing of M . Fix an auxiliary metric as above. We have the distribution of orthogonal tangent 2-planes

$$\{P_x := \text{span}(v(x))^\perp\}_{x \in M} .$$

These planes P_x are oriented by the unique orientation which added to $v(x)$ agrees with the given orientation on $T_x M$. This actually defines an oriented rank-2 vector bundle ξ_v on M whose strict equivalence class does not depend on the choice of the combing representative nor of the auxiliary metric. We consider the oriented Euler class

$$e^2(\xi_v) \in \Omega^2(M) = \Omega_1(M) .$$

In fact $e^2(\xi_v) \in \mathcal{H}^2(M; \mathbb{Z})$. If ξ_v has a non vanishing unitary section w orthogonal to v , then (v, w) extends to the unique orthonormal framing $\mathcal{F} = (v, w, z)$ of $T(M)$ such that the orientations are compatible. So ξ_v is trivial if and only if it admits a nowhere vanishing section w as above. We know from section 13.4 that

LEMMA 19.31. *The bundle ξ_v has a non vanishing section, if and only if the Euler class $e^2(\xi_v)$ vanishes.* □

As usual, $\omega^2(\xi_v) \in \mathcal{H}^2(M; \mathbb{Z}/2\mathbb{Z})$ is the image of $e^2(\xi_v)$ via the natural forgetting map.

Combing comparison class. We can associate to an ordered pair of unitary combings (v, v') of M a smooth section $v \times v'$ of ξ_v as follows. At a point $x \in M$ where $v(x) \neq \pm v'(x)$, $v \times v'(x) \in P_v(x) \subset T_x M$ is the “vector product” of $v(x)$ and $v'(x)$, i.e. the only tangent vector such that

- $\|v \times v'(x)\|_{g(x)}^2 = 1 - g(v, v')^2$;
- $v \times v'(x)$ is $g(x)$ -orthogonal to $v(x)$ and $v'(x)$;
- $(v(x), v'(x), v \times v'(x))$ is an oriented basis of $T_x M$.

At a point $x \in M$ where $v(x) = \pm v'(x)$, we set $v \times v'(x) = 0$.

If the two unitary combings v and v' are generic, the section $v \times v'$ of F_v is transverse to the zero section and the zero locus

$$C := \{x \in M \mid v \times v'(x) = 0\} \subset M$$

is a disjoint collection of simple closed curves. Moreover, $C = C_+ \cup C_-$, where

$$C_+ = \{x \in M \mid v(x) = v'(x)\} \quad \text{and} \quad C_- = \{x \in M \mid v(x) = -v'(x)\}.$$

By the very definition of $e^2(\xi_v)$, C can be oriented to represent the Euler class of ξ_v . Indeed, let $E(\xi_v)$ denote the total space of ξ_v , $M_0 \subset E(\xi_v)$ the zero-section and $M_1 = v \times v'(M) \subset E(\xi_v)$. Under the natural identification of M with M_0 the submanifold C is identified with $M_0 \cap M_1$. By transversality, for each $x \in M_0 \cap M_1$ the natural projection $p_x : T_x E(\xi_v) \rightarrow P_v(x)$ maps isomorphically the image under $(v \times v')'_*$ of the fiber $N_x(C)$ of the normal bundle of $TC \subset TM|_C$ onto $P_v(x)$. Therefore, the given orientation on $\xi_v(x)$ can be pulled-back to $N_x(C)$ and, together with the orientation of $T_x M$, it induces an orientation on $T_x C$ in a standard way.

DEFINITION 19.32. An ordered pair of unitary combings (v, v') of M such that $v \times v'$ is a section of ξ_v transverse to the zero section will be called a *generic pair* of unitary combings. We define the *comparison class* $\alpha(v, v') \in \Omega^2(M)$ of a generic pair of unitary combings as the class $[C_-]$ carried by the collection of curves C_- oriented as part of the oriented zero locus of $v \times v' : M \rightarrow \xi_v$ representing $e^2(\xi_v)$.

LEMMA 19.33. *Let (v, v') be a generic pair of unitary combings of M . Then,*

$$\alpha(v, v') = -\alpha(v', v) \quad \text{and} \quad \alpha(v, -v') = \alpha(v', -v).$$

Proof : For each $x \in C$ the equality $\xi_v(x) = \xi_{v'}(x)$ holds, with the orientations of $\xi_v(x)$ and $\xi_{v'}(x)$ being the same or different according to, respectively, whether $x \in C_+$ or $x \in C_-$. We may choose a tubular neighborhood $U = U(C)$ such that the restrictions of the tangent plane fields $P_v|_U$ and $P_{v'}|_U$ are so close that there is a vector bundle isomorphism $\varphi : \xi_v|_U \xrightarrow{\cong} \xi_{v'}|_U$ which is the identity map on the intersections $P_v(x) \cap P_{v'}(x)$, $x \in U$, is orientation-preserving near $C_+ = \{x \in M \mid v(x) = v'(x)\}$ and orientation-reversing near $C_- = \{x \in M \mid v(x) = -v'(x)\}$. Since $\varphi \circ (v \times v') = v \times v' = -v' \times v$ and $-v' \times v$ is obtained by composing the section $v' \times v$ with the orientation-preserving automorphism of $F_{v'}$ given by minus the identity on each fiber, the orientation on C_- as part of the zero locus of $v \times v' : M \rightarrow \xi_v$ is the opposite of its orientation as part of the zero locus of $v' \times v = -v \times v' : M \rightarrow \xi_{v'}$. This implies $\alpha(v, v') = -\alpha(v', v)$. Similarly, the orientation on C_+ as part of the zero locus of $v \times (-v') : M \rightarrow \xi_v$ coincides with its orientation as part of the zero locus of $(-v') \times v = v' \times (-v) : M \rightarrow \xi_{v'}$, which implies $\alpha(v, -v') = \alpha(v', -v)$. □

LEMMA 19.34. *Let (v, v') be a generic pair of unitary combings of M . Then,*

$$e^2(\xi_v) - e^2(\xi_{v'}) = 2\alpha(v, v').$$

Proof : According to the definitions we have

$$e^2(\xi_v) = \alpha(v, v') + \alpha(v, -v') \quad \text{and} \quad e^2(\xi_{v'}) = \alpha(v', v) + \alpha(v', -v).$$

The statement follows applying Lemma 19.33 after taking the difference of the two equations.

□

Combing Pontryagin surgery. Let v be a unitary combing of M and $C \subset M$ an oriented, simple closed curve such that the positive, unit tangent field along C is equal to $v|_C$ and there is a trivialization

$$j : D^2 \times S^1 \xrightarrow{\cong} U(C)$$

of a tubular neighborhood of C in M such that

$$v \circ j = j_*(\partial/\partial\phi),$$

where ϕ is a periodic coordinate on the S^1 -factor of $D^2 \times S^1$. Let (ρ, θ) be polar coordinates on the D^2 -factor. Following terminology from [BP], we say that a unitary combing v' is obtained from v by *Pontryagin surgery* along C if, up to homotopy, v' coincides with v on $M \setminus U(C)$ and

$$v' \circ j = j_* \left(-\cos(\pi\rho) \frac{\partial}{\partial\phi} - \sin(\pi\rho) \frac{\partial}{\partial\rho} \right)$$

on $U(C)$.

REMARK 19.35. A basic fact not used in this paper is that any two combings of M are obtained from each other, up to homotopy, by Pontryagin surgery [BP].

LEMMA 19.36. *Let v be a unitary combing of M and $\beta \in H^2(M; \mathbf{Z})$. Then, possibly after a homotopy of v , there is a unitary combing v' such that (v, v') is a generic pair of unitary combings and*

$$\alpha(v, v') = \beta.$$

Proof : Let $C \subset M$ be an oriented simple closed curve representing the Poincaré dual of β and let $j : D^2 \times S^1 \rightarrow U(C)$ be a trivialization of a neighborhood of C . Without loss of generality we may assume that the pull-back $j^*(g)$ of the auxiliary metric g on M is the standard product metric on $D^2 \times S^1$. After a suitable homotopy of v the assumptions to perform Pontryagin surgery on v along C are satisfied. Consider a normal disc $D_{\phi_0} = j(D^2 \times \{\phi_0\})$ and let $p = D_{\phi_0} \cap C$. Then, $T_p D_{\phi_0}$ coincides, as an oriented 2-plane, with $P_v(p)$ as well as with the $g(p)$ -orthogonal subspace of $T_p C$ inside $T_p M$. Let v' be a unitary combing obtained from v by first performing a Pontryagin surgery on $U(C)$ and then applying a small generic perturbation supported on a small neighborhood of $M \setminus U(C)$. Then, (v, v') is a generic pair of unitary combings and $C = \{x \in M \mid v(x) = -v'(x)\}$. By the definition of $\alpha(v, v')$, to prove the statement it suffices to show that the given orientation of C coincides with its orientation as part of the zero set of $v \times v' : M \rightarrow \xi_v$. Near C we have

$$(v \times v') \circ j = j_* \left(-\sin(\pi\rho) \frac{\partial}{\partial\theta} \right) = j_* \left(\frac{\sin(\pi\rho)}{\rho} \left(y \frac{\partial}{\partial x} - x \frac{\partial}{\partial y} \right) \right),$$

where $x = \rho \cos \theta$ and $y = \rho \sin \theta$ are rectangular coordinates on the D^2 -factor. Observe that j_* sends the pair $(\partial/\partial x, \partial/\partial y)$ to an oriented framing of ξ_v . Using the resulting trivialization of ξ_v we can write locally the restriction of $v \times v'$ to the disc D_{ϕ_0} followed by projection onto ξ_v as follows:

$$v \times v'|_{D_{\phi_0}} : (x, y) \mapsto \frac{\sin(\pi\rho)}{\rho} (y, -x) = \pi(y, -x) + \text{higher order terms.}$$

It is easy to compute that $(v \times v')_* \circ j_*$ sends $\partial/\partial x$ to $-\pi\partial/\partial y$ and $\partial/\partial y$ to $\pi\partial/\partial x$, and since the matrix $\begin{pmatrix} 0 & \pi \\ -\pi & 0 \end{pmatrix}$ has determinant $\pi^2 > 0$ this shows that the restriction of $(v \times v')_*$ to the normal bundle to C composed with the projection onto ξ_v is orientation-preserving along C , concluding the proof. \square

We are ready to state a main theorem of this section.

THEOREM 19.37. *Let M be a compact connected oriented boundaryless 3-manifold. The following facts are equivalent to each other and all hold true.*

- (1) M is parallelizable.
- (2) There exists a combing v of M such that $e^2(\xi_v) = 0$.
- (3) There exists a combing v of M such that $e^2(\xi_v)$ is an even class that is of the form $e^2(\xi_v) = 2\beta$ for some $\beta \in \mathcal{H}^2(M; \mathbb{Z})$.
- (4) For every combing v of M , $e^2(\xi_v)$ is an even class.
- (5) For every combing v of M , $\omega^2(\xi_v) = 0 \in \mathcal{H}^2(M; \mathbb{Z}/2\mathbb{Z})$.

Proof : First we prove the equivalence between the five statements. We will prove $(j) \Leftrightarrow (j+1)$ for $j = 1, \dots, 4$.

(1) \Rightarrow (2): If $\mathcal{F} = (v, w, z)$ is a framing of M , then $e^2(\xi_v) = 0$.

(1) \Leftarrow (2): we have already remarked above that if $e^2(\xi_v) = 0$ then v can be extended to a global framing $\mathcal{F} = (v, w, z)$.

(2) \Rightarrow (3): this is trivial.

(2) \Leftarrow (3): If $e^2(\xi_v) = 2\beta$, then by applying the Pontryagin surgery to v and the class $-\beta$, we get v' such that

$$e^2(v') = -2\beta + e^2(v) = 0 .$$

(3) \Rightarrow (4): If $e^2(\xi_v) = 2\beta$ and v' is another combing, then by Lemma 19.34

$$e^2(v') = 2(\alpha(v, v') - \beta) .$$

(3) \Leftarrow (4): this is trivial.

(4) \Rightarrow (5): this is trivial.

(4) \Leftarrow (5): this follows from Lemma 19.30.

The equivalence between the five statements is achieved. Now it is enough to show that at least one among them holds true. We are going to prove that statement (5) holds true:

PROPOSITION 19.38. *For every combing v of M , $\omega^2(\xi_v) = 0 \in \mathcal{H}^2(M; \mathbb{Z}/2\mathbb{Z})$.*

Equivalently, we have to show that for every compact closed surface F embedded in M , possibly F non orientable, then

$$\omega^2(\xi_v) \sqcup [F] = 0 \in \mathbb{Z}/2\mathbb{Z}$$

that is

$$\omega^2(i^*\xi_v) \sqcup [F] = 0$$

where $i : F \rightarrow M$ is the inclusion, and it is not restrictive to assume that F is connected.

Consider the restriction $i^*T(M)$ of the tangent bundle of M to F . Similarly consider $i^*\xi_v$. Then we have the following two splittings as direct sum:

$$i^*T(M) = i^*\xi_v \oplus \epsilon^1 = T(F) \oplus \nu$$

where ν denotes the orthogonal line bundle along F , and ϵ^1 is the restriction to F of the trivial line bundle which has v as nowhere vanishing section. Here is the key lemma:

LEMMA 19.39. *For every combing ν of M and every compact closed embedded surface F we have*

$$\omega^2(i^*\xi_\nu) \sqcup [F] = \omega^2(T(F)) \sqcup [F] + (\omega^1(\det T(F)) \cup \omega^1(\nu)) \sqcup [F] .$$

Claim: *Lemma 19.39 \Rightarrow Proposition 19.38:*

Proof of the Claim: If F is orientable, then the identity of Lemma 19.39 reduces to

$$\omega^2(i^*\xi_\nu) \sqcup [F] = \omega^2(T(F)) \sqcup [F] = \chi_2(F)$$

and we conclude because $\chi(F)$ is even. If F is non orientable, then $F \sim h\mathbf{P}^2(\mathbb{R})$, that is the connected sum of h copies of the projective plane. As M is orientable, then ν is isomorphic to the determinant line bundle $\det T(F)$, hence also in this case

$$\omega^2(i^*\xi_\nu) \sqcup [F] = \chi_2(F) + (\langle \omega^1(F) \cup \omega^1(F) \rangle) \sqcup [F] = 2 - h + h = 0 \pmod{2} .$$

□

Proof of Lemma 19.39: Consider again the two splittings

$$i^*T(M) = i^*\xi_\nu \oplus \epsilon^1 = T(F) \oplus \nu$$

realized geometrically by a field of splittings

$$T_x M = P_x \oplus l(x) = T_x F \oplus \nu(x), \quad x \in F$$

where $l(x)$ is the (oriented) line spanned by $\nu(x)$, while $\nu(x)$ is the (unoriented) line orthogonal to $T_x F$. Let s be a generic section of $i^*(\xi_\nu)$, that is a field of vectors $s = \{s(x) \in P_x\}_{x \in F}$. For every $x \in F$, the direct sum $T_x F \oplus \nu(x)$ induces the decompositions

$$s(x) = s_F(x) + s_\nu(x), \quad \nu(x) = v_F(x) + v_\nu(x) .$$

By transversality we can assume that:

- (1) $\{s = 0\}$ is a finite number of points representing $\omega^2(i^*\xi_\nu)$.
- (2) $s_\nu = \{s_\nu(x)\}$ and $v_\nu = \{v_\nu(x)\}$ are generic sections of ν , so that both are smooth curves on F representing $\omega^1(\nu)$ and moreover are transverse to each other in F , so that their intersection represents $\omega^1(\eta) \cup \omega^1(\eta) = \omega^1(\det T(F)) \cup \omega^1(\nu)$.
- (3) $\{s = 0\} \cap \{v_\nu = 0\} = \emptyset$.
- (4) $s_F = \{s_F(x)\}$ is a generic section of $T(F)$ so that $\{s_F = 0\}$ is a finite number of points representing $\omega^2(T(F))$.

For every finite set X , let $\#X$ denote the number of its elements mod (2). Then we have

$$\begin{aligned} < \omega^2(i^*\xi_\nu) \sqcup [F] = \#\{s = 0\}, < \omega^2(T(F)) \sqcup [F] = \#\{s_F = 0\} \\ (\omega^1(\det T(F)) \cup \omega^1(\nu)) \sqcup [F] = \#(\{v_\nu = 0\} \cap \{s_\nu = 0\}) . \end{aligned}$$

So we have to prove that

$$\#\{s = 0\} = \#\{s_F = 0\} + \#(\{v_\nu = 0\} \cap \{s_\nu = 0\}) .$$

On the other hand, obviously

$$\{s_F = 0\} = (\{v_\nu = 0\} \cap \{s_F = 0\}) \amalg (\{v_\nu \neq 0\} \cap \{s_F = 0\}) .$$

We claim that

$$\{v_\nu \neq 0\} \cap \{s_F = 0\} = \{s = 0\}$$

in fact, by item (3) above

$$\{s = 0\} = \{v_\nu \neq 0\} \cap \{s = 0\} ;$$

clearly

$$\{v_\nu \neq 0\} \cap \{s = 0\} \subset \{v_\nu \neq 0\} \cap \{s_F = 0\} ;$$

on the other hand if $s(x) \neq 0$, then $s_F(x) \neq 0$, because the projection $P_x \rightarrow T_x F$ is an isomorphism being $v_\nu(x) \neq 0$. It remains to check that

$$\#(\{v_\nu = 0\} \cap \{s_F = 0\}) = \#(\{v_\nu = 0\} \cap \{s_\nu = 0\}) .$$

Set $C = \{v_\nu = 0\}$ and $j : C \rightarrow F$ the inclusion of this smooth curve; for every $x \in C$, the line $\nu(x)$ is contained in P_x and we have the splitting as direct sum

$$P_x = (P_x \cap T_x F) \oplus \nu(x) .$$

Hence we have a splitting as direct sum of line bundles

$$j^* \xi_\nu = \lambda \oplus j^* \nu$$

These two line bundles are isomorphic to each other; in fact along every component of C , $j^* \xi_\nu$ is trivial because it is oriented, then the two line bundles are both trivial or both non trivial; eventually

$$\omega^1(\lambda) \sqcup [C] = \omega^1(j^* \nu) \sqcup [C] .$$

We conclude by noticing that the restriction of s_F and s_ν are respectively generic sections of these line bundles. □

The proof of Proposition 19.38, hence of the main Theorem 19.37 is now complete. □

REMARK 19.40. Lemma 19.34 shows in particular that the class $2\alpha(v, v')$ does not depend on the choice of the generic pair of combing representatives v and v' . If $\mathcal{F} = (v, w, z)$ is a framing of $T(M)$, and v' is any other combing, then $e^2(v') = 2\alpha(v', v)$. Thanks to the framing, v' is encoded by a map $s : M \rightarrow S^2$ and it is not hard to verify (do it by exercise) that $\alpha(v', v) = s^*(u) \in \Omega^2(M)$, where u is the usual standard generator of $\Omega^2(S^2) \sim \mathbb{Z}$. More generally, if \tilde{v} is another combing encoded by the map say $\tilde{s} : M \rightarrow S^2$, then $\alpha(\tilde{v}, v') = \tilde{s}^*(u) - s^*(u)$ which by the way shows that the comparison class itself only depends on the combings as homotopy classes.

19.6.4. Classification of framings. We provide a classification of the framings on M with respect to a given reference framing \mathcal{F}_0 . Then any other framing \mathcal{F} is encoded by a map

$$\rho_{\mathcal{F}} : M \rightarrow SO(3)$$

considered up to homotopy. The set $[M, SO(3)]$ can be endowed with a group structure by pointwise multiplication. As $SO(3) \sim \mathbf{P}^3(\mathbb{R})$ there is a natural homomorphism (see Section 13.1)

$$\psi : [M, SO(3)] \rightarrow \mathcal{H}^1(M; \mathbb{Z}/2\mathbb{Z}), [h] \rightarrow h^*([\mathbf{P}^2(\mathbb{R})]) .$$

Denote by $p : S^3 \rightarrow SO(3) \sim \mathbf{P}^3(\mathbb{R})$ the universal covering. Recall that by Corollary 17.6

$$[M, S^3] \sim \Omega_0^{\mathcal{F}}(M) \sim \mathbb{Z}$$

every homotopy class being classified by the common \mathbb{Z} -degree of its representative maps. There is a natural homomorphism

$$\phi : [M, S^3] \rightarrow [M, \mathbf{P}^3(\mathbb{R})], [f] \rightarrow [p \circ f] .$$

Finally we can state

PROPOSITION 19.41. *The homomorphism sequence*

$$0 \rightarrow \mathbb{Z} \xrightarrow{\phi} [M, \mathbf{P}^3(\mathbb{R})] \xrightarrow{\psi} \mathcal{H}^1(M; \mathbb{Z}/2\mathbb{Z}) \rightarrow 0$$

is exact.

Proof: If $p \circ f$ is homotopic to a constant map, then the homotopy can be lifted to S^3 , hence f is homotopically trivial and ϕ is injective.

Given $g : M \rightarrow SO(3)$, $\psi([g]) = 0$ if and only if g lifts to S^3 , hence the kernel of ψ is the image of ϕ .

We are left to prove that ψ is surjective. We use a spine \mathbf{P}_0 of M_0 constructed in Section 19.1.2. First one proves that every homomorphism $\alpha : \pi_1(\mathbf{P}_0) \rightarrow \mathbb{Z}/2\mathbb{Z}$ is induced by a map $j : \mathbf{P}_0 \rightarrow \mathbf{P}^2(\mathbb{R})$. Let $a : (S^1, e) \rightarrow (\mathbf{P}^1(\mathbb{R}), x_0)$, $\mathbf{P}^1(\mathbb{R}) \subset \mathbf{P}^2(\mathbb{R})$, be a loop which generates $\pi_1(\mathbf{P}^2(\mathbb{R})) \sim \mathbb{Z}/2\mathbb{Z}$. We choose a maximal tree T in the singular set of the spine \mathbf{P}_0 , and define $j : \text{Sing}(\mathbf{P}_0) \rightarrow \mathbf{P}^2(\mathbb{R})$ by setting it constantly equal to x_0 on T , while on every other edge of the singular set it is either equal to the constant map or to a according to the value of α on the loop determined by such an edge. On the boundary of every region of \mathbf{P}_0 there is an even number of edges at which j is not constant, hence the map j extends to the whole of \mathbf{P}_0 . Now we consider $\mathbf{P}^2(\mathbb{R}) \subset \mathbf{P}^3(\mathbb{R}) \sim SO(3)$. The map j extends to M_0 , and finally to the whole of M because $\pi_2(SO(3)) = 0$. □

19.6.5. Classification of combings. Fix a reference framing \mathcal{F}_0 of M as above. The set of combings of M can be identified with $[M, S^2] \sim \Omega_1^{\mathcal{F}}(M)$ by the Pontryagin construction of Chapter 17. We want to make it explicit. There is a natural forgetting projection

$$\pi : \Omega_1^{\mathcal{F}}(M) \rightarrow \Omega_1(M) .$$

In fact $\pi(v) = v^*(u) \in \Omega^2(M) = \Omega_1(M)$, where $u = [y_0]$ is a standard generator of $\Omega^2(S^2)$. We have already remarked that

$$e^2(\xi_v) = 2\pi(v) .$$

The projection π is onto. So we have to understand the fibre $\pi^{-1}(x)$ of every $x \in \Omega_1(M)$. If we consider the comparison class $\alpha(v, v')$ as the first obstruction in order that the combings coincide, to distinguish the combings in a same fibre we have to point out a secondary comparison invariant. Given an oriented framed knot (K, \mathfrak{f}) in M which projects to x , we can modify the framing to $(K, n\mathfrak{f})$ by adding n twists to the given framing. This gives a transitive action of \mathbb{Z} on such a fibre. We have to understand when (K, \mathfrak{f}) and $(K, n\mathfrak{f})$ represent the same element of $\Omega_1^{\mathcal{F}}(M)$. Assume this is the case, realized by a framed surface S in $M \times I$. By taking the double of $M \times I$, diffeomorphic to $M \times S^1$, the double Σ of S embedded therein is an oriented boundaryless surface in $M \times S^1$ such that $[\Sigma] \bullet [\Sigma] = n \in \Omega_0(M \times S^1)$. We have

$$([\Sigma] - \lambda) \bullet [M \times \{1\}] = 0$$

where $\lambda = [K \times S^1]$. Then

$$\begin{aligned} ([\Sigma] - \lambda) \bullet ([\Sigma] - \lambda) &= [\lambda] \bullet [\lambda] = 0 \\ n &= 2([\Sigma] - \lambda) \bullet \lambda = [\Sigma] - \lambda \bullet e^2(\xi_v) . \end{aligned}$$

Then there are two cases:

- $\pi(v)$ is a torsion element, then also $e^2(\xi_v)$ is so, and then $n = 0$.
- $e^2(\xi_v)$ is not a torsion element; if d is the biggest integer such that $\pi(v) = d\beta$ for some β , then

$$n = 0 \pmod{2d} .$$

Summarizing, we have

PROPOSITION 19.42. (1) Every framing \mathcal{F}_0 on M determines a surjective map

$$\pi : \Omega_1^{\mathcal{F}}(M) \rightarrow \Omega^2(M)$$

such that for every combing $v \in \Omega_1^{\mathcal{F}}(M)$, $2\pi(v) = e^2(\xi_v)$.

(2) If $e^2(\xi_v)$ is a torsion element, set $d = 0$; then for every $v, v_0 \in \pi^{-1}(\pi(v_0))$ it is defined a secondary comparison invariant $h(v, v_0) \in \mathbb{Z}/2d\mathbb{Z} = \mathbb{Z}$ such that $v = v_0$ iff and only if $h(v, v_0) = 0$.

(3) If $e^2(\xi_v) = 2\pi(v)$ is not a torsion element, let d be the maximum integer such that $\pi(v) = d\beta$ for some β , then it is defined a secondary comparison invariant $h(v, v_0) \in \mathbb{Z}/2d\mathbb{Z}$ such that $v = v_0$ iff and only if $h(v, v_0) = 0$.

□

REMARK 19.43. If $\Omega_1(M)$ has no non trivial elements of order 2, then the map π does not depend on the choice of the framing \mathcal{F}_0 . On the other hand, let $M = \mathbf{P}^3(\mathbb{R})$. Fix a trivialization $b : U\mathbf{P}^3(\mathbb{R}) \rightarrow \mathbf{P}^3(\mathbb{R}) \times S^2$ of its unitary tangent bundle (associated to a framing \mathcal{F}_0). Identify $\mathbf{P}^3(\mathbb{R})$ with $SO(3)$. Consider a new trivialization c defined by $c(b^{-1}(p, y)) = (p, py)$. Let v be a combing encoded by a constant map with respect to b . Then $\pi_b(v) = 0$. On the other hand $\pi_c(v)$ is represented by the loop in $SO(3)$ given by the rotation in a certain plane, hence it is not trivial.

Finally we want to outline that the Pontryagin surgery acts transitively.

PROPOSITION 19.44. *Let v, v_0 be combings of M . Then they are connected by a finite sequence of combing Pontryagin surgeries.*

Proof : Up to Pontryagin surgery we can assume that the first comparison obstruction vanishes: $\alpha(v, v_0) = 0$. Fix a reference framing \mathcal{F}_0 as above. Then combings are encoded by $[M, S^2] \sim \Omega_1^{\mathcal{F}}(M)$, and we can assume that v, v_0 belong to a same fibre of $\pi : \Omega_1^{\mathcal{F}}(M) \rightarrow \Omega^2(M)$. It remains to prove that up to further Pontryagin surgeries say on v_0 which stay in the given fibre, also the second comparison invariant $h(v, v_0)$ vanishes. As $\alpha(v, v_0) = 0$, we can assume that v and v_0 coincide on $M_0 = M \setminus \text{Int}(B)$ where B is a standard 3-disk in a chart of M diffeomorphic to \mathbb{R}^3 and moreover they are constantly equal to a base point $s_0 \in S^2$ on $\partial B \sim S^2$. As $B/\partial B \sim S^3$ and is endowed with the base point $p_0 = [\partial B]$, then v and v_0 determines two elements $\bar{v}, \bar{v}_0 \in \pi_3(S^2)$. We know that this last is isomorphic to \mathbb{Z} and is generated by the Hopf map \mathfrak{h} ; then $\bar{v} = n\mathfrak{h}$, $\bar{v}_0 = n_0\mathfrak{h}$. It is not hard to verify that (with the notations of Proposition 19.42)

$$h(v, v_0) = n - n_0 \pmod{2d}$$

where d only depends on the given fibre of π . Then we are essentially reduced to prove that starting from the map $c_0 : S^3 \rightarrow S^2$, $c_0(x) = s_0$, for every $n \in \mathbb{Z}$, we can realize a map $f : S^3 \rightarrow S^2$ such that $[f] = [n\mathfrak{h}]$ by means of a finite sequence of Pontryagin surgeries. Assume that $B \subset \mathbb{R}^3$ is a suitably big radius; consider the following loops in \mathbb{R}^3 :

$$\gamma_{\pm} : [0, 2\pi] \ni \phi \rightarrow 3(0, \cos(\phi), \pm \sin(\phi)) \in \mathbb{R}^3 .$$

Parametrize a tubular neighbourhood of γ_{\pm} as:

$$\begin{aligned} j_{\pm} : [0, 2] \times [0, 2\pi] \times [0, 2\pi] \ni (\rho, \theta, \phi) \rightarrow \\ \rightarrow (3 + \rho \cos(\theta))(0, \cos(\phi), \pm \sin(\phi)) + (\rho \sin(\theta), 0, 0) \in \mathbb{R}^3 . \end{aligned}$$

Now, by taking convex combinations in S^2 on the region $1 \leq \rho \leq 2$, we can construct a homotopy between the constant field s_0 and the field

$$e_{\pm}^{(0)}(j_{\pm}(\rho, \theta, \phi)) = (0, -\sin(\phi), \pm \cos(\phi)) = \dot{\gamma}_{\pm}(\phi)/3 .$$

Up to rescaling the field, we can apply the Pontryagin surgery along the tube $\{\rho \leq 1\}$. This produces another field $e_{\pm}^{(1)}$ which coincides with $e_{\pm}^{(0)}$ outside the tube and is given there by:

$$e_{\pm}^{(1)}(j_{\pm}(\rho, \theta, \phi)) =$$

$$= -\cos(\pi\rho)(0, -\sin(\phi), \pm\cos(\phi)) - \sin(\pi\rho)(\sin(\theta), \cos(\theta)\cos(\phi), \pm\cos(\theta)\sin(\phi)) .$$

The value $(-1, 0, 0)$ is regular and the inverse image is the curve

$$\delta_{\pm} : [0, 2\pi] \ni \phi \rightarrow j_{\pm}(1/2, \pi/2, \phi) = (1/2, 3\cos(\phi), \pm 3\sin(\phi)) .$$

By direct computation one checks that the framing on δ_{\pm} is given by the normal field

$$\nu_{\pm}(\phi) = -\frac{\sin(\phi)}{\pi}(1, 0, 0) - \frac{\cos(\phi)}{2}(0, \cos(\phi), \pm\sin(\phi))$$

so that one finally checks that

$$lk(\delta_{\pm}, \delta_{\pm} + \nu_{\pm}) = \mp 1 .$$

We can therefore conclude that starting from the constant field c_0 , the element of $\pi_3(S^2)$ which corresponds to the integer n can be realized by $|n|$ Pontryagin surgeries. □

19.7. What is the simplest proof that $\Omega_3 = 0$?

We have discussed several proofs that $\Omega_3 = 0$ and of the equivalent Lickorish-Wallace theorem on surgery equivalence. By travelling through again these proofs we can ask about the “simplest one” that is, more precisely, the one with minimal mathematical background. Rohlin’s first proof certainly uses non trivial fact about immersions of 3-manifolds in \mathbb{R}^5 . Lickorish’s proof arises as a corollary of an important result on the surface mapping class group which nevertheless is rather expensive if one is just interested about the corollary. The proof in [Rourke] is certainly very simple and self-contained, provided one assumes Smale theorem. Then the most basic proof would be obtained by combining one with minimal background of parallelizability of 3-manifolds (as in Section 19.6) and the specialization to the 3-dimensional case of Proposition 16.8.

19.8. The bordism group of immersed surfaces into a 3-manifold

Let S be a compact boundaryless surface and M be a connected boundaryless 3-manifold. As usual $[S, M]$ denotes the set of homotopy classes of maps $f : S \rightarrow M$. By using Section 7.8 (see in particular Remark 7.25) we know that every class $\alpha \in [S, M]$ contains generic immersions whose local models are the same as for immersions in \mathbb{R}^3 described therein. Generic immersions in a given homotopy class can be considered up to the finer relation of *regular homotopy*. This is a particular case of Smale-Hirsch theory, but the resulting classification is a bit implicit; several efforts have been made to make it more transparent. Closer to the themes of the present text, we can consider generic immersions of compact boundaryless surfaces into a given 3-manifold up to a notion of bordism which extends the one of embedded bordism. In this section we mainly refer to [HH], [Pi], [BS]. We will refer to these papers for details of some proofs. Nevertheless, we hope to eventually provide a substantial report.

Let us recall first the notion of *regular homotopy*.

DEFINITION 19.45. Let $\alpha \in [S, M]$; we say that two generic immersions $f_0, f_1 : S \rightarrow M$ belonging to α are *regularly homotopic* if there are connected by a homotopy $f_t, t \in [0, 1]$, such that f_t is an immersion for every t . We denote by $\mathcal{R}[S, M]_{\alpha}$ the set of regular homotopy classes in α , and by $[f]_r$ the class of a generic immersion belonging to α .

Let us define now the i -bordism.

DEFINITION 19.46. Let $f_j : S_j \rightarrow M$, $j = 0, 1$, be generic immersions of surfaces into the 3-manifold M . Then f_0 is *i-bordant* with f_1 if there is a 3-dimensional triad (W, S_0, S_1) and an immersion $F : W \rightarrow M \times [0, 1]$ such that $F \pitchfork M \times \{0, 1\}$ and $f_j \times \{j\} = F|_{S_j}$, $j = 0, 1$.

Some first remarks:

- As usual, *i*-bordism is an equivalence relation. Denote by $[f]_i$ the equivalence class of a generic immersion f .
- If $\phi : S \rightarrow S$ is a smooth diffeomorphism, then for every generic immersion $f : S \rightarrow M$, f is *i*-bordant with $f \circ \phi$: the bordism relation incorporates reparametrizations of surfaces, so that for every immersion f , the intrinsic object of interest is rather its image $f(S) \subset M$ which is a kind of singular surface in M .
- If $f_0, f_1 : S \rightarrow M$ are connected by a regular homotopy $F : S \times [0, 1] \rightarrow M$, then

$$F \times \text{id} : S \times [0, 1] \rightarrow M \times [0, 1]$$

realizes a *i*-bordism of f_0 with f_1 . Hence in a sense *i*-bordism embodies regular homotopy, but we stress that reparametrization is not included in the definition of regular homotopy.

- Denote by $\mathcal{I}_2(M)$ the set of *i*-bordism classes. The disjoint union defines an abelian *semigroup* structure $(\mathcal{I}_2(M), +)$ with 0 the class of the empty immersion:

$$[S_1, f_1]_i + [S_2, f_2]_i = [S_1 \amalg S_2, f_1 \amalg f_2]_i .$$

A priori it is not evident that it is a group, that is it is not clear how to define the inverses $-[f]_i$.

- By using 1-handles embedded in M we can define a *connected sum* between immersions $f_1 \# f_2 : S_1 \# S_2 \rightarrow M$ such that

$$[S_1 \# S_2, f_1 \# f_2]_i = [S_1, f_1]_i + [S_2, f_2]_i \in \mathcal{I}_2(M) ;$$

it follows that every class in $\mathcal{I}_2(M)$ can be represented as $[S, f]_i$ where S is connected, and the operation $+$ is induced by $\#$ as well.

We will be mainly concerned with compact 3-manifolds M and we distinguish two cases depending on M being orientable or non orientable. When M is orientable, a main ingredient of the discussion will be a certain quadratic enhancement of the intersection form of surfaces associated to every such an immersion. We will discuss diffusely the orientable case following [HH], [Pi], [BS]. Later we will give a few indications about the non orientable one.

An important special case is $M = S^3$ [Pi]. In this case, for every surface S there is only one homotopy class of maps $f : S \rightarrow S^3$, and via the usual inclusion $\mathbb{R}^3 \subset \mathbb{R}^3 \cup \infty = S^3$, we easily see by transversality that $\mathcal{R}[S, S^3] = \mathcal{R}[S, \mathbb{R}^3]$ and $\mathcal{I}_2(S^3) = \mathcal{I}_2(\mathbb{R}^3)$.

19.8.1. From immersions in orientable 3-manifolds to quadratic enhancements of surface intersection forms. Let us recall the current setting:

- M is an *orientable* connected compact boundaryless 3-manifold;
- S is a compact and boundaryless surface, not necessarily orientable. For a while we will assume also that S is connected.
- $f : S \rightarrow M$ is a generic immersion.

We know that M is parallelizable, so let us fix an auxiliary *framing* \mathcal{F} of M , that is a trivialization of the tangent bundle $T(M)$, considered up to homotopy of framings. This includes also the choice of an orientation of M . The framing \mathcal{F} can be equivalently identified with an ordered triple $\mathcal{F} = (v, w, z)$ of pointwise linearly independent tangent vector fields on M . By taking an auxiliary riemannian metric g on M , we can also assume that these fields are pointwise orthonormal.

Let K be a smooth knot in M ($K \sim S^1$). Give K an auxiliary orientation. The restriction of v along K can be considered as a map $v : K \rightarrow S^2$, then up to homotopy of framings we can assume that v coincides along K with the positive unitary tangent field on K ; thus $\mathbf{n}_{\mathcal{F}} := (w, z)$ is along K an ordered couple of pointwise orthonormal vectors normal to K , i.e. it is a *normal framing*; it determines a tubular neighbourhood $N(K)$ of K in M equipped with a trivialization. If $\mathbf{n} = (w_1, z_1)$ is any other normal framing along K , then by using $\mathbf{n}_{\mathcal{F}}$ as a reference, we encode \mathbf{n} by a map $\rho : K \rightarrow SO(2) \sim S^1$ and we associate to \mathbf{n} the degree $\phi(\mathbf{n}) := \deg_{\mathbb{Z}}(\rho) \in \mathbb{Z}$, so that obviously $\phi(\mathbf{n}_{\mathcal{F}}) = 0$. This number can be equivalently obtained as follows. The framing $\mathbf{n}_{\mathcal{F}}$, that is its first component w , determines a longitude $l_{\mathcal{F}}$ on $\partial N(K)$ oriented in such a way that the projection onto K is of degree 1. Another framing \mathbf{n} also determines a longitude $l_{\mathbf{n}}$. Then

$$\phi(\mathbf{n}) = [l_{\mathbf{n}}] \bullet [l_{\mathcal{F}}] \in \Omega_0(\partial N(K)) \sim \mathbb{Z}$$

where $\partial N(K)$ is endowed with the boundary orientation.

We say that \mathbf{n} differs from $\mathbf{n}_{\mathcal{F}}$ by $\phi(\mathbf{n})$ positive or negative twists along K . Clearly we can modify \mathbf{n} by adding an arbitrary number of twists. We stipulate that $\mathbf{n}_{\mathcal{F}}$ is the basic *odd* normal framing of K determined by \mathcal{F} and that a normal framing is *odd* if it differs from $\mathbf{n}_{\mathcal{F}}$ by an even number of twists. Otherwise a framing is *even*. So we have distributed the normal framings to K into two classes; we note that these classes of *odd/even framings do not depend on the choice of the auxiliary orientation on K* . If we apply this construction to $S^1 = \partial D^2 \subset \mathbb{R}^2 \subset \mathbb{R}^3$ with respect to the standard constant framing of \mathbb{R}^3 , we realize that even (resp. odd) normal framings along S^1 are characterized by the property that they cannot (they can) be extended to a framing of the restriction of $T(\mathbb{R}^3)$ to the spanning 2-disk D^2 . The typical even framing along S^1 has as field w the ingoing normals to S^1 , tangent to D^2 ; the associated longitude is determined by a collar of S^1 in D^2 .

Consider now a smooth circle C on the surface S . By transversality we can assume that the restriction $f|_C$ of the immersion is an embedding of C onto a knot $K \subset f(S) \subset M$ which extends to an embedding of a tubular neighbourhood $U(C)$ of C in S onto a band $B(K)$ in $f(S)$, with core K . We can assume that $B(K)$ is the transverse intersection with $f(S)$ of a neighbourhood $N(K)$ of K in M as above. We can apply to this knot K the above considerations. Give C , hence K an auxiliary orientation. Let us orient $\partial B(K)$ in such a way that the natural projection onto its core K is a degree-2 covering. Fix an *even* normal framing \mathcal{F}_e along K , with associated longitude $l_{\mathcal{F}_e}$. For every normal framing \mathbf{n} define as above $\phi_e(\mathbf{n}) \in \mathbb{Z}$ with respect to \mathcal{F}_e . We can consider the integer

$$[\partial B(K)] \bullet [l_{\mathcal{F}_e}] \in \Omega_0(\partial N(K)) \sim \mathbb{Z} .$$

Then set

$$q_f(C) := [\partial B(K)] \bullet [l_{\mathcal{F}_e}] \pmod{4} .$$

If $U(C)$ is annular, then a normal framing, say u , of C in S gives rise to a normal framing $\mathbf{n}_f = (w, z)$ of K in M , provided that w is the image of u by the differential of f , and (v, w, z) agrees with the given orientation of $T_x M$ along K , where v is tangent to K as above. Then

$$[\partial B(K)] \bullet [l_{\mathcal{F}_e}] = 2\phi_e(\mathbf{n}_f) .$$

We can say that $q_f(C)$ counts the number mod(4) of *half-twists* the band $B(K)$ makes along its core K . The same interpretation makes sense also when $U(C)$ is a Möbius strip. In this case $[\partial B(K)] \bullet [l_{\mathcal{F}_e}]$ is odd.

REMARK 19.47. If $M = \mathbb{R}^3$, $q_f(C)$ is the linking number mod(4) between $\partial B(K)$ and the core K of the band (co-oriented as before).

If $L = \amalg_j C_j$ is the finite disjoint union of smooth circles on S , set

$$q_f(L) = \sum_j q_f(C_j) .$$

We have

LEMMA 19.48. (1) *The procedure described above well defines a function q_f which associates to every finite disjoint union of smooth circles on the surface S considered up to ambient isotopy, an element $q_f(C) \in \mathbb{Z}/4\mathbb{Z}$.*

(2) *The function q_f verifies the conditions stated at the end of Chapter 15; hence by setting for every $\alpha \in \eta_1(S)$, $q_f(\alpha) := q_f(C)$, where C is any smooth circle on S representing α , we well define a quadratic enhancement of $(\eta_1(S), \bullet_S)$.*

As for item (1), it is a bit complicated to show that $q_f(C)$ is invariant up to ambient isotopy. In fact a generic isotopy between two copies of C which embed in M by the restriction of f , might pass through non injective immersions and we have to check that these accidents are immaterial with respect to the value of q_f . As for item (2), basically one is reduced to a local analysis at a single crossing point (by the way also the choice of the simplification of the crossing turns to be immaterial out); this is not very hard. We left the details as an exercise. □

REMARKS 19.49. 1) The choice of the framing \mathcal{F} is not immaterial, in the sense that the quadratic form q_f might depend on such a choice. However, it will be immaterial with respect to the statement of main Theorems 19.50 and 19.54. In the case of $S^3 = \mathbb{R}^3 \cup \infty$ we will deal with the unique framing (up to homotopy) of \mathbb{R}^3 .

2) The above construction would be placed in a more conceptual framework in terms of *spin structures* on M and induced pin^- on S . In fact (addressed to a reader who knows this matter), given $f : S \rightarrow M$ as above, as M is oriented, $f^*T(M) = T(S) \oplus \Lambda(S)$ where this last is the determinant bundle of S . For every spin structure Θ on M , we have the pull-back spin structure $f^*(\Theta)$ on $f^*T(M)$, and there is a natural bijection between the spin structures on $T(S) \oplus \Lambda(S)$ and the pin^- structures on S ; moreover these last are in natural bijection with the quadratic enhancements of the intersection form of S . Rather than the framing \mathcal{F} itself, above we have used the spin structure carried by it. In this framework the statement of last lemma becomes conceptually clear and even simpler to prove. However, to our present aims *we have preferred the above direct operative presentation, without introducing the general theory*. A reader interested to it is mainly addressed to [KT].

3) The constructions of the present section work as well if M is any framed 3-manifold, not necessarily compact.

19.8.2. Adding kinks. Let $f : S \rightarrow M$ be a generic immersion, S connected. Let C be a smooth circle on S such that f restricts to an embedding of a small tubular neighbourhood $U(C)$ of C in S . We are going to modify the immersion f by *adding a kink along C* . This nice and crucial construction has been introduced in [HH]. Denote by $K = f(C)$, $B(K) = f(U(C))$. $U(C)$ either is an annulus or a Möbius strip. As M is orientable, then any tubular neighbourhood $N(K)$ of K in M is diffeomorphic to the product $S^1 \times D^2$. As usual we can assume that $\partial N(K)$ is transverse to $f(S)$ and that $B(K) = N(K) \cap f(S)$. We have two possible models for the pair $(N(K), B(K))$, depending on $U(C)$ being orientable or not. Consider (D^2, X) where $X = \{(x_1, x_2) \in D^2; x_1 x_2 = 0\}$. $X = X_1 \cup X_2$, $X_1 = \{x_2 = 0\}$, $X_2 = \{x_1 = 0\}$.

- If $U(C)$ is an annulus then the model for $(N(K), B(K))$ is the mapping cylinder of $\text{id} : (D^2, X_1) \rightarrow (D^2, X_1)$.

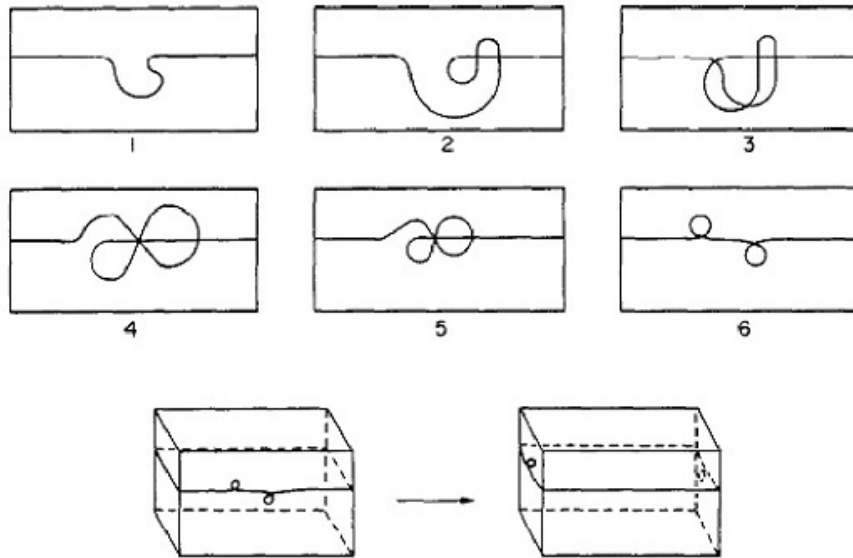

FIGURE 1. A kink box.

• If $U(C)$ is a Möbius strip then the model for $(N(K), B(K))$ is the mapping cylinder of $-\text{id} : (D^2, X_1) \rightarrow (D^2, X_1)$.

Accordingly there are two models for adding a kink along C . Let \tilde{X}_1 be the image of an immersion $\alpha : [-1, 1] \rightarrow D^2$ such that \tilde{X}_1 is contained in $x_2 \geq 0$, is symmetric with respect to the x_2 -axis, has one double point, and coincides with the inclusion of X_1 near the end-points. Denote by $-\tilde{X}_1$ its image by $-\text{id}$.

If $U(C)$ is an annulus the kink model is very simple: take the mapping cylinder of $\text{id} : (D^2, \tilde{X}_1) \rightarrow (D^2, \tilde{X}_1)$.

If $U(C)$ is a Möbius strip, then the kink model is more complicated (see [HH] pages 104-105); one constructs a so called “kink box” that is a determined immersion of the 2-disk in D^3 with one triple point. A way to visualize this immersion is given in Figure 1. First we consider the immersion of D^2 into $D^3 = D^2 \times D^1$ described by the movie in the first two rows; it results the bottom left-hand picture; then we apply an isotopy to it and reach the eventual kink box of the bottom right-hand picture. We can consider it as an immersion $X_1 \times [-1, 1]$ in $D^2 \times [-1, 1]$ such that for some $\epsilon > 0$:

- (1) The image of $X_1 \times [-1, -1 + \epsilon]$ coincides with the embedding of $\tilde{X}_1 \times [-1, -1 + \epsilon]$;
- (2) The image of $X_1 \times [1 - \epsilon, 1]$ coincides with the embedding of $-\tilde{X}_1 \times [1 - \epsilon, 1]$;
- (3) The image along the boundary of $D^2 \times [-1, 1]$ coincides with the inclusion of $X_1 \times [-1, 1]$;
- (4) There is one triple point in the middle.

Denote by Z the image of this immersion.

Then the kink model is obtained by taking

$$(D^2 \times [0, 1], Z) / (x_1, x_2, 0) \sim (-x_1, -x_2, 1) .$$

Z projects to a new immersion of $U(C)$ which agrees with $B(K)$ along the boundary.

By using these models we can modify the given immersion $f : S \rightarrow M$ just along $U(C)$ and get $f_C : S \rightarrow M$. It is clear by the construction that f_C is homotopic to f .

19.8.3. Determination of $\mathcal{R}[S, M]_\alpha$. We give here a first remarkable application of adding kinks. Let $f : S \rightarrow M$ be a generic immersion as above and q_f the associated quadratic enhancement of $(\eta_1(S), \bullet_S)$. We know by Lemma 15.22 that every other enhancement is *abstractly* of the form

$$q'(x) = q_f(x) + 2x \bullet u$$

for a unique $u \in \eta_1(S)$. Adding kinks is a natural way to realize it geometrically, by keeping the homotopy class α of f fixed. Assume that $u = [C]$, C being a smooth circle on S to which we can apply the kink construction. If C' is another smooth circle on S which intersects transversely C at one point. Denote as above $U(C')$ a small tubulat neighbourhood of C' in S . Then it is immediate that $f(U(C'))$ and $f_C(U(C'))$ differ by one full twist. Recalling the geometric definition of q_f in terms of counting half twists mod (4), one easily realizes that

$$q_{f_C}([C']) = q_f([C']) + 2[C'] \bullet [C] \pmod{4}$$

as desired.

This result is the key to prove

THEOREM 19.50. *Let S be a compact connected boundaryless surface, $\alpha \in [S, M]$. Denote by $Q(S)$ the set of quadratic enhancements of $(\eta_1(S), \bullet_S)$. Then the map*

$$q : \mathcal{R}[S, M]_\alpha \rightarrow Q(S), \quad q([f]_r) = q_f$$

is well defined and bijective.

Proof : An outline: it is not hard to check that it is well defined. We already know that the map q is onto. The proof that it is injective is non trivial and consists in rephrasing Smale-Hirsch immersion theory in terms of the quadratic enhancement. This theory provides a simply transitive action of $\eta_1(S)$ on $\mathcal{R}[S, M]_\alpha$; a main result of [HH] is that this action can be realized by adding kinks as well as the one on $Q(S)$; so eventually q is an equivariant bijection. □

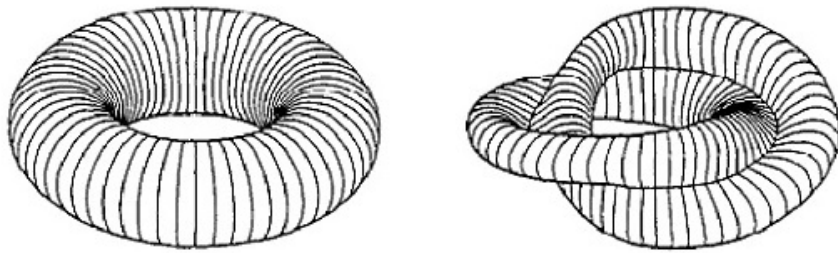

FIGURE 2. Immersed tori.

REMARKS 19.51. (*Basic immersed surfaces in \mathbb{R}^3*) We refer to [Pi].

1) By Theorem 19.50, $\mathcal{R}[S^2, \mathbb{R}^3]$ is trivial i.e. it is reduced to one point. A regular homotopy connecting the standard inclusion i of S^2 in \mathbb{R}^3 with $-i$ is called a *sphere eversion* whose surprising existence was discovered by S. Smale [S0].

2) The elementary surface bricks, besides the sphere, are the torus $S^1 \times S^1$ and the projective plane $\mathbf{P}^2(\mathbb{R})$. We denote by T the standard embedding of the

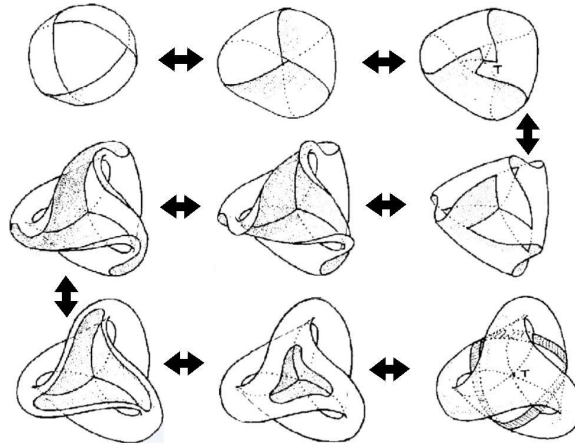

FIGURE 3. Boy's surface.

torus in \mathbb{R}^3 bounding a solid torus. We denote by \tilde{T} the immersion obtained by adding a kink along a meridian of T and then along the privileged longitude of T which bounds a 2-disk in the complement of the solid torus. These realize the two quadratic enhancements of $(\eta_1(S^1 \times S^1), \bullet)$ (up to isometry) - T and \tilde{T} are illustrated in Figure 2.

There is a famous immersion of the projective plane with one triple point called *Boy's surface* - see for instance the body and the references of [A \mathbf{p}]). Figure 3 suggests how to construct it. Such an immersion denoted by B and \bar{B} the mirror of B , that is B composed with a reflection at a hyperplane of \mathbb{R}^3 , realize the two quadratic enhancements of $(\eta_1(\mathbf{P}^2(\mathbb{R}), \bullet))$.

19.8.4. Determination of $(\mathcal{I}_2(M), +)$. First we will point out a few invariants up to i-bordism.

The Arf-Brown invariant. Let $f : S \rightarrow M$ be a generic immersion, S connected, with the associated q_f . Accordingly with section 15.6, we can consider the Arf-Brown multiplicative invariant

$$\gamma(f) := \gamma(q_f) \in U_8 \sim \mathbb{Z}/8\mathbb{Z}$$

where for simplicity we have written $\gamma(q_f)$ instead of $\gamma(S, \bullet_S, q_f)$. If $f : S \rightarrow M$, where $S = \coprod_j S_j$ is union of several connected components, then set

$$\gamma(f) := \prod_j \gamma(f_j)$$

where $f_j = f|_{S_j}$. We have

LEMMA 19.52. *Let $f_j : S_j \rightarrow M$ be generic immersions, $j = 0, 1$. If $[f_0]_i = [f_1]_i$, then $\gamma(q_{f_0}) = \gamma(q_{f_1})$.*

Proof : Let (W, S_0, S_1) , $F : W \rightarrow M \times [0, 1]$ be as in Definition 19.46, and let $t : M \times [0, 1] \rightarrow [0, 1]$ be the projection. Without loss of generality we can assume that $t \circ F$ is a Morse function on the triad. Then consider the possible accidents when passing through a critical point of $t \circ F$. Modifications occur locally in a chart of M at the critical point. We use the notations of Remark 19.51. At local minima/maxima a new spherical component appears/disappears. For the other kinds of critical point, there are three possibilities:

- one performs the immersed connected sum of two components of the surface;
- one performs the connected sum with either a standard torus T or a Klein bottle immersion $B\#\bar{B}$.

In every case the value of γ does not change (for all details one can see [Pi], pp. 432-433).

□

So we have detected a first main U_8 -valued invariant $\gamma([f]_i)$ defined on $\mathcal{I}_2(M)$.

From now on we will use the standard isomorphism $U_8 \sim (\mathbb{Z}/8\mathbb{Z}, +)$ and hence adopt the additive notation.

Other invariants. Let $f : S \rightarrow M$ be a generic immersion (S not necessarily connected). It is obvious just by forgetting part of the structure of $[f]_i$, that $[f] = [S, f] \in \eta_2(M)$ is invariant under i -bordism. Recall the quotient module $\mathcal{H}^1(M, \mathbb{Z}/2\mathbb{Z})$ of $\eta^1(M) = \eta_2(M)$ defined in Corollary 13.3; recall also that the cup product \sqcup descends to this quotient with values in $\eta^2(M) = \eta_1(M)$. Keep the notation $[f]$ for its image in $\mathcal{H}^1(M, \mathbb{Z}/2\mathbb{Z})$.

Denote by $\Sigma \subset S$ the non-injectivity locus of f . We claim that the image $\Sigma_f := f(\Sigma)$ determines an element $[\Sigma_f] \in \eta_1(M)$. In fact the components of $f^{-1}(\Sigma_f)$ are of two kinds:

- 1) they are member of a couple $\tilde{C} = C \amalg C'$ such that $f(C) = f(C')$ and f is generically 1 – 1 on such a C . In such a case select one C in each couple;
- 2) Components \tilde{C} such that $\tilde{C} = f^{-1}(f(\tilde{C}))$ and in such a case f is generically 2-1 on \tilde{C} .

Then select one component C in every couple \tilde{C} of the first kind; for the second kind one finds a quotient C of \tilde{C} such that f induces a map (we keep the name) $f : C \rightarrow M$, such that $f(C) = f(\tilde{C})$ and f is generically 1-1. Then set

$$[\Sigma_f] := \sum_{\tilde{C}} [C, f] \in \eta_1(M) .$$

The triple points of $f(S)$ determines a class $t_f \in \eta_0(M) \sim \mathbb{Z}/2\mathbb{Z}$. We have

LEMMA 19.53. *If $[f_0]_i = [f_1]_i$, then $[\Sigma_{f_0}] = [\Sigma_{f_1}] \in \mathcal{H}^1(M, \mathbb{Z})$ and $t_{f_0} = t_{f_1} \in \eta_0(M)$.*

Proof : Let (W, S_0, S_1) , $F : W \rightarrow M \times [0, 1]$ be as in Definition 19.46. We can assume that also F is generic. Then $F(\Sigma_F)$ is a kind of singular surface properly embedded into $M \times [0, 1]$ such that $F(\Sigma_F) \cap (M \times \{0, 1\}) = f_0(\Sigma_0) \amalg f_1(\Sigma_1)$; by using the regular surface $F^{-1}(\Sigma_F)$ we can explicitly define a triad which connects the sum of the components that form $[\Sigma_{f_0}]$ and $[\Sigma_{f_1}]$ respectively. Similarly for the triple points.

□

Consider the product

$$\Gamma(M) = \eta_1(M) \times \mathcal{H}^1(M, \mathbb{Z}/2\mathbb{Z}) \times \mathbb{Z}/8\mathbb{Z}$$

endowed with the *twisted* group structure defined by the operation:

$$(\delta, h, a) + (\delta', h', a') := (\delta + \delta' + h \sqcup h', h + h', a + a') .$$

We can state now the main result of this section.

THEOREM 19.54. *The map $\psi : \mathcal{I}_2(M) \rightarrow \Gamma(M)$ well defined by*

$$[f]_i \rightarrow ([\Sigma_f], [f], \gamma(f))$$

is a semigroup isomorphism. In particular the semigroup $(\mathcal{I}_2(M), +)$ is a group. Moreover, the invariant $t_{[f]_i}$ is determined by the others.

The rest of this section is occupied by the proof of Theorem 19.54. It is immediate that ϕ is a semigroup homomorphism.

The 3-sphere. If $M = S^3$, Theorem 19.54 specializes to

THEOREM 19.55. *The map $\phi : \mathcal{I}_2(S^3) \rightarrow \mathbb{Z}/8\mathbb{Z}$, $\phi([f]_i) = \gamma(f)$ is a group isomorphism.*

Proof : This is a main result of [P*i*] to which we refer for all details. We can use \mathbb{R}^3 instead of S^3 . Note that we know a priori that $\mathcal{I}_2(\mathbb{R}^3)$ is a group : inverses are obtained by mirror image along a hyperplane. By using connected sums (or disjoint unions) of the basic immersed surfaces of Remark 19.51 it is easy to prove that ϕ is onto. By Proposition 19.50 (and the classification of surfaces) one realizes that every generic immersion $f : S \rightarrow \mathbb{R}^3$ is regularly homotopic to a connected sum of several copies of the standard embedding T and one among the following eight surfaces

$$B, \bar{B}, K_0, K_+, K_-, K_+\#B, K_0\#\tilde{T}, K_-\#\bar{B}$$

where $K_0 = B\#\bar{B}$, $K_+ = B\#B$, $K_- = \bar{B}\#\bar{B}$. Up to *i*-bordism the T -components are immaterial and one eventually gets that eight explicit generators suffice and this achieves the desired bijection onto $\mathbb{Z}/8\mathbb{Z}$. □

The map ψ is onto. Let us prove now in general that the map ψ is surjective.

LEMMA 19.56. *The map $\psi : \mathcal{I}_2(M) \rightarrow \Gamma(M)$ is onto.*

Proof : As $M = M\#S^3$, we see that $\mathcal{I}_2(M)$ contains the subgroup $\mathcal{I}_2(S^3)$; it consists of the classes with a representative contained in a 3-disk of M .

It contains also the subset $E(M)$ given by the classes which are represented by embedded surfaces. By the description of $\mathcal{H}^1(M, \mathbb{Z}/2\mathbb{Z})$ as the embedded surfaces in M up to embedded bordism, we see that $E(M)$ is in fact the image of $\mathcal{H}^1(M, \mathbb{Z}/2\mathbb{Z})$ in $\mathcal{I}_2(M)$ by a natural quotient map.

Let $(\delta, h, a) \in \Gamma(M)$. Represent h by an embedding $e : S \rightarrow M$. Represent δ by a knot K in M . Consider the boundary $\mathcal{T} \sim S^1 \times S^1$ of a tubular neighbourhood of K in M . Add a kink along a longitude K' of K on \mathcal{T} and get a generic immersion $j : \mathcal{T} \rightarrow M$. By construction $\delta = [\Sigma_j]$, while $[j] = 0 \in \mathcal{H}^1(M, \mathbb{Z}/2\mathbb{Z})$, hence $[j] \sqcup [e] = 0$. By the elementary fact that γ is onto in the case of S^3 , there is $s : S \rightarrow S^3$ such that $\gamma(s) = a - \gamma(e) + \gamma(j)$. Clearly $[s] = 0$ and $[\Sigma_s] = 0$. Finally

$$\psi([j]_i + [e]_i + [s]_i) = (\delta, h, a) .$$

□

A normal decomposition of *i*-bordism classes. Now the idea is that every $[f]_i$ admits a certain *normal decomposition* modelled on the classes used to prove that ψ is onto. Precisely we have the following key proposition.

PROPOSITION 19.57. *Every $[f]_i$ can be represented by a sum*

$$[f]_i = [j]_i + [e]_i + [s]_i$$

where $j : \mathcal{T} \rightarrow M$ is obtained by adding a kink along a longitude K' on the boundary \mathcal{T} of a tubular neighbourhood of a knot K in M , $[e]_i \in E(M)$, $[s]_i \in \mathcal{I}_2(\mathbb{R}^3)$ where \mathbb{R}^3 is a chart of M . Moreover, we can choose the decomposition in such a way that $q_j(K') = 0$ hence so that $\gamma(j) = 0$.

Proof : We will proceed in several steps. We adopt the notations of Remark 19.51, in particular B, \bar{B} are the two versions of Boy's surface.

Step 1. $[f]_i = [f']_i + [s]_i$, where f' has no triple points and $[s]_i \in \mathcal{I}_2(\mathbb{R}^3)$.

Notice that $K_0 = B\#\bar{B}$ is regularly homotopic to the usual immersion of the Klein bottle in \mathbb{R}^3 without triple points (and a plane of symmetry) and recall that $[K_0]_i = 0$. Similarly if x_0 is a triple point of f , either $f\#B$ or $f\#\bar{B}$ is regularly homotopic to \tilde{f} with one triple point less than f , and either $[f]_i = [\tilde{f}]_i + [\bar{B}]_i$ or $[f]_i = [\tilde{f}]_i + [B]_i$. So the step is achieved by induction on the number of triple points.

Then the double line locus $\Sigma_{f'}$ consists of the disjoint union of a finite number of embedded circles in M . If K is such a circle, then it has a neighbourhood in $f(S)$ which is a bundle over K , sub-bundle of a tubular neighbourhood of K in M , with fibre isomorphic to $X = \{(x_1, x_2) \in D^2; x_1 x_2 = 0\}$. We can count the number mod(4) of *quarter turns* this configuration does when moving along K . Denote it by $l(K) \in \mathbb{Z}/4\mathbb{Z}$; it characterizes the bundle. The cases $l(K) = 0, 2$ correspond to the situation where $f' : (f')^{-1}(K) \rightarrow K$ is a trivial double covering; if $l(K) = 0$ then the two components of this inverse image have annular tubular neighbourhoods in S' ; if $l(K) = 2$, both have Möbius strip neighbourhoods. The cases $l(K) = 1, 3$ correspond to a non trivial double covering.

Step 2. $[f]_i = [f']_i + [s]_i$ as in Step 1 and moreover we can require that $\Sigma_{f'}$ is connected.

If $\Sigma_{f'}$ is not connected, there are two components K and K' and points $p \in K$, $p' \in K'$ belonging to the closure of a same connected component of $M \setminus \text{Im}(f')$. So there is a smooth simple arc σ in M , connecting p and p' and without any further intersection with $\text{Im}(f')$. Locally in chart of M at p , the image of f' looks like two transverse planes P_1 and P_2 . Similarly at p' , with planes P'_1 and P'_2 . Remove from the image of f' the intersection, say B_p , of the interior of a small 3-ball centred at p , with transverse boundary spheres. The closure of B_p is the union $D_1 \cup D_2$ of two 2-disks, $D_j \subset P_j$, $j = 1, 2$, which intersect transversely at a segment of K . Do similarly at p' . Possibly up to reordering the planes, we can attach two embedded 1-handles H_j along the arc σ , $j = 1, 2$, with attaching tube $T_{a,j} = D_j \cup D'_j$, and transverse b -tubes such that $T_{b,1} \cap T_{b,2}$ consists of two disjoint double arcs having as endpoints the four points of $(D_1 \cap D_2) \cup (D'_1 \cap D'_2)$. Ultimately, (up to corner smoothing) we get the immersed surface

$$\text{Im}(\tilde{f}) := (\text{Im}(f') \setminus (B_p \cup B_{p'})) \cup (T_{b,1} \cup T_{b,2})$$

which by construction is i -bordant with f' , alike f' has no triple points, the two knots K and K' of $\Sigma_{f'}$ have fused into one knot K'' of $\Sigma_{\tilde{f}}$, so that this last has one component less. The step is achieved by induction on the number of components of $\Sigma_{f'}$. We stress that by the above construction we have furthermore that

$$l(K'') = l(K) + l(K') .$$

Step 3. Let $[f]_i = [f']_i + [s]_i$ be as in Step 2 (i.e. with $\Sigma_{f'} = K$ connected) and assume that $l(K) = 0, 2$. Then it is not restrictive to assume that $l(K) = 0$.

By using the results about the group $\mathcal{I}_2(\mathbb{R}^3)$ we see that there is an immersion s_0 of the Klein bottle in a chart of M , without triple points and having connected $\Sigma_{s_0} = K_0$ such that $l(K_0) = 2$. Take

$$[f' \# s_0]_i + [s]_i - [s_0]_i = [f]_i$$

and apply Step 2 to $f' \# s_0$. This achieves the step.

Let $[f]_i = [f']_i + [s]_i$ be as in Step 3, so that $l(K) = 0$. Set $q_f(K) := q_f(C)$, where C is a component of $(f')^{-1}(K)$. It is well defined and either $q_f(K) = 0$ or $q_f(K) = 2$.

Step 4. Let $[f]_i = [f']_i + [s]_i$ be as in Step 3, so that $l(K) = 0$. Then it is not restrictive to assume that $q_f(K) = 0$

There is an immersion s_1 of the torus in a chart of M , without triple points and with connected $\Sigma_{s_1} = K_1$ such that $l(K_1) = 0$ and $q_{s_0}(K_1) = 2$. If $q_f(K) = 2$, take

$$[f' \# s_0]_i + [s]_i - [s_0]_i = [f]_i$$

and apply Step 2 to $f' \# s_0$. This achieves the step.

Step 5. Let $[f]_i = [f']_i + [s]_i$ be as in Step 2 (i.e. with $\Sigma_{f'} = K$ connected) and assume that $l(K) = 0, 2$. Then Proposition 19.57 holds in this case.

By Steps 3 and 4 we can assume that $l(K) = 0$ and $q_f(K) = 0$. Perform a Rohlin surgery along K (recall Section 7.9). This splits f' in two disjoint immersed surfaces: an embedding e and the immersion j of torus having as image a product sub-bundle of (the interior of) a tubular neighbourhood $N(K)$ of K in M with fibre a lemniscate; the germ of j along K equals the germ of f' . It is easy to see that j is obtained by adding a kink along a longitude C on the boundary \mathcal{T} of a smaller tubular neighbourhood $N'(K) \subset N(K)$ and that $q_{\mathcal{T}}(C) = q_f(K) = 0$. By construction $[f]_i = [j]_i + [e]_i + [s]_i$. The Proposition is proved under such restrictive hypotheses.

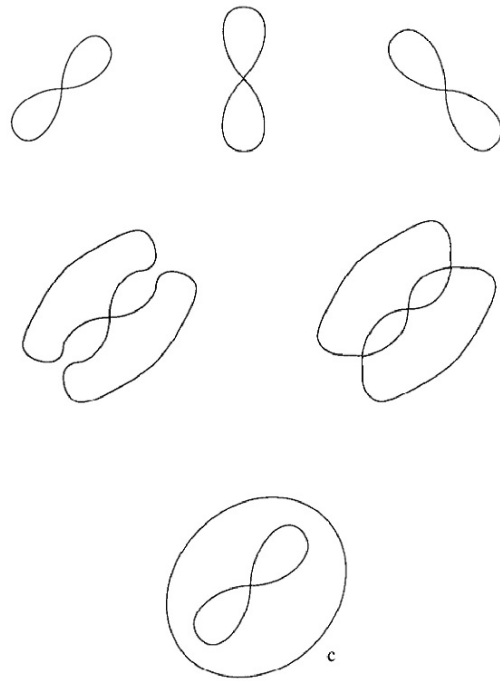

FIGURE 4. An auxiliary immersed surface.

To proceed we need the following lemma.

LEMMA 19.58. *There is an immersion s_2 in \mathbb{R}^3 of a surface F of Euler-Poincaré characteristic $\chi(F) = -1$ such that:*

- 1) s_2 has one triple point;
- 2) Σ_{s_2} consists of the union of a smooth circle K_2 endowed with an X -bundle neighbourhood in the image of s_2 such that $l(K_2) = 1$, and a lemniscate in a 2-disk D contained in the image of s_2 , intersecting K at the triple point; D is transverse to K and the germ of the lemniscate at the triple point is a fibre of the X -bundle along K .

Proof : First we construct an immersion of a surface G with boundary in $D^2 \times D^1$. This is given by the movie of Figure 4. Note that at the initial time $t = -1$ and at the final time $t = 1$ of the movie we see two copies of a same lemniscate L ; in the final configuration L is encircled by a smooth circle c . Finally we complete G by filling the curve c by a 2-disk, and identifying by the identity of

\mathbb{R}^2 the two copies of L over -1 and 1 respectively. One readily check that this is the image of an immersion of a surface F with the required properties. □

We denote by \bar{s}_2 the mirror image of the immersion s_2 as above.

Step 6. *Proposition 19.57 holds in full generality.*

It remains to prove it when $[f]_i = [f']_i + [s]_i$ is again as in Step 2, but we assume now that $l(K) = 1, 3$. Let $l(K) = 1$. By realizing s_2 in a chart of M , take

$$[f' \# \bar{s}_2]_i + [s]_i + [s_2]_i = [f]_i$$

and apply Step 2 to $f' \# \bar{s}_2$. In this way we reach a decomposition $[f]_i = [f'']_i + [s']_i$, where $\Sigma_{f''}$ is qualitatively similar to the one of s_2 , that is it consists of the union of a smooth circle K'' endowed with an X -bundle neighbourhood in the image of f'' and a lemniscate in a 2-disk D contained in the image of f'' , intersecting K'' at one triple point; D is transverse to K'' and the germ of the lemniscate at the triple point is a fibre of the X -bundle along K'' . Moreover, $l(K'') = 0$. By applying Step 4, we can also assume that $q_{f''}(K'') = 0$. Now, although there is a triple point, we can apply Steps 5 along K'' . This produces a decomposition of the form $[f]_i = [j]_i + [g]_i + [s']_i$ where $[j]_i$ has the required final properties, while Σ_g is contained in D and consists of the union of a lemniscate fibre of j and two further simple double circles. We can eliminate such circle by applying again Steps 4, 5; eventually we get a required decomposition

$$[f]_i = [j]_i + [e]_i + [s'']_i .$$

If at the beginning $l(K) = 3$, we manage similarly by exchanging the roles of s_2 and \bar{s}_2 respectively. This achieves Step 6.

REMARK 19.59. *We stress that when $l(K) = 0, 2$, the images of j and e in the normal decomposition obtained above are disjoint. When $l(K) = 1, 3$, they intersect producing one triple point. In the first case $[\Sigma_f] \bullet [f] = 0 \in \eta_0(M) \sim \mathbb{Z}/2\mathbb{Z}$, in the second $[\Sigma_f] \bullet [f] = 1$.*

The proof of Proposition 19.57 is now complete. □

The map ψ is injective. We have

LEMMA 19.60. *The map $\psi : \mathcal{I}_2(M) \rightarrow \Gamma(M)$ is injective.*

Proof : We can use normal decompositions of i-bordism classes. Assume that

$$\psi([j]_i + [e]_i + [s]_i) = \psi([j']_i + [e']_i + [s']_i) .$$

As $[e] = [e'] \in \mathcal{H}^1(M, \mathbb{Z}/2\mathbb{Z})$ then they are bordant by means of an embedded bordism, hence $\gamma(e) = \gamma(e')$. As $\gamma(j) = \gamma(j') = 0$, then $\gamma(s) = \gamma(s')$ and by Theorem 19.55, we have $[s]_i = [s']_i$. It remains to prove that $[j]_i = [j']_i$. Now $[j]_i + [j']_i = [j \# j']_i$ and this last can be obtained from the embedding $\mathcal{T} \# \mathcal{T}'$ by adding kinks along two disjoint circles K', K'' at which the quadratic enhancement vanishes. Let C be a smooth circle on $\mathcal{T} \# \mathcal{T}'$ such that $[K'] + [K''] = [C] \in \eta_1(\mathcal{T} \# \mathcal{T}')$. Then up to regular homotopy $j \# j'$ can be obtained by adding a kink to $\mathcal{T} \# \mathcal{T}'$ along C . It follows from the hypotheses that $[C] = 0 \in \eta_1(M)$ and that the quadratic enhancement of $\mathcal{T} \# \mathcal{T}'$ vanishes on C . We claim that in such a situation $[j \# j']_i = 0$. As the same considerations hold for $[j \# j]_i$, we will eventually conclude $[j]_i = -[j]_i$ and hence that $[j]_i = [j']_i$ as desired.

We need the following lemma.

LEMMA 19.61. *Let F be a compact surface with connected boundary embedded into a framed 3-manifold N (F might be non orientable and N non compact). Then the normal framing of $C = \partial F$ determined by a collar in F is even with respect to the ambient framing.*

Proof: We can extend the embedding of F to a generic immersion of the double $D(F)$ of F into N . If F is orientable, up to corner smoothig, we can take the boundary of a tubular neighbourhood of F in N ; if F is not orientable, we can take an immersion which looks like in the orientable case along the boundary and have double lines in the interior of F . We use the ambient framing to define a quadratic enhancement $q_{D(F)}$ of the intersection form of the double. As $[C] = 0 \in \eta_1(D(F))$, then $q_{D(F)}(C) = 0$. This means exactly that the collar normal framing is even. \square

To simplify the notations, denote by $f : S \rightarrow M$ the embedding $\mathcal{T} \# \mathcal{T}'$, so that $q_f(C) = 0$. As $[C] = 0 \in \eta_1(M)$, then there is a (possibly non orientable) embedded Seifert surface $F \subset M$ such that $\partial F = C$. Apply Lemma 19.61 to F . As also $q_f(C) = 0$, then both the normal framings of C determined by a tubular neighbourhood in S and by a collar in F respectively differ to each other by an even number of twists. It follows that we can “roll up” F in a tubular neighbourhood U of C in M , in such a way that F is transverse to S along C , and intersects transversely S outside U .

Assume first that $F = D$ is a 2-disk. Let τ be a Dehn twist on S along C . For every $\alpha \in \eta_1(S)$,

$$\tau_*(\alpha) = \alpha + ([C] \bullet \alpha)[C] .$$

As $q_f(C) = 0$, by recalling the geometric definition of q_f , we readily see that

$$q_{f_C} = q_{f \circ \tau} .$$

We claim that f_C and $f \circ \tau$ are homotopic (equivalently f and $f \circ \tau$ are homotopic). To prove the last statement, let U denote now a tubular neighbourhood of C in S ; there is a natural map $h : U \rightarrow D$ which realizes a homotopy to a point of $f|_C$. Then f and $f \circ \tau$ are homotopic to maps f' and f'' such that:

- they coincide outside U ;
- f'_U and f''_U factor through h .

Since D is contractible they are homotopic relatively to $S \setminus U$. By Theorem 19.50, $[f_C]_r = [f \circ \tau]_r$, hence $[f_C]_i = [f]_i$.

It remains to reduce to such a special case $F = D$. To this aim, consider a generic Morse function

$$r : F \rightarrow [0, 1]$$

such that $r^{-1}(0) = C$ and r has no minima and only one maximum. Then we can find a non critical value $\lambda \in [0, 1)$ such that $D = r^{-1}([\lambda, 1])$ is a 2-disk embedded in M with boundary denoted by \hat{C} . By following the level lines of r between 0 and λ we can modify (S, f, C) into a $(\hat{S}, \hat{f}, \hat{C})$ such that $[f]_i = [\hat{f}]_i$. Between two consecutive critical values we can extend the isotopy between level lines to a diffeotopy of M . At a critical point the analysis is local in a chart of M : the critical level of r containing a crossing point x_0 is contained in a “critical” surface S' with one isolated singular point at x_0 isomorphic to a cone centred at x_0 and bases at two disjoint circles; F and S' intersect along such a critical level, transversely outside x_0 . By such a local analysis one realizes that $q_{\hat{f}}(\hat{C}) = 0$ and that $[f_C]_i = [\hat{f}_{\hat{C}}]_i$. So we have reduced to the special case $F = D$ and the Lemma is proved. \square

The proof of the main Theorem 19.54 is now complete. \square

19.8.5. More quasi-framing. Now we give a further proof of the existence of a quasi-framing on M based on some constructions established in Section 19.8.1.

By contradiction, assume that there is v such that

$$\beta := \omega^2(\xi_v) \neq 0 .$$

Let K be an oriented knot in M which represents $e^2(\xi_v)$. By forgetting the orientation, K represents $\omega^2(\xi_v)$. Then it follows from the hypotheses that (see Section 19.6.2):

- (1) There is a framing \mathcal{F}' of $T(M)$ over $M \setminus K$.
- (2) There is a (possibly non orientable) compact boundaryless surface F embedded into M such that $F \pitchfork K$ at exactly one points.

Let $N(K) \sim S^1 \times D^2$ be a tubular neighbourhood of K in M transverse to F . By removing the interior of $N(K)$ from F , we can assume to get a surface F_0 properly embedded in

$$M' := M \setminus \text{Int}(N(K))$$

such that $C := \partial F_0$ is a meridian of $\partial N(K)$ bounding a fibre D of $N(K)$. As in Section 19.8.1, we can use the framing \mathcal{F}' to construct a quadratic enhancement of the intersection form of every surface immersed into M' . By Lemma 19.61, we see that the normal framing of C determined by a collar of C in F_0 - equivalently by a collar of C in the meridian disk D - is *even* with respect to \mathcal{F}' , and it is also *even* with respect to a framing of a 3-ball containing D . Then the normal framing determined by \mathcal{F}' is odd within the 3-ball, consequently \mathcal{F}' can be extended over a neighbourhood $U \sim D \times [-1, 1]$ of D in $N(K)$; as the closure of $N(K) \setminus U$ is a closed 3-ball, we have eventually obtained an almost-framing of M . By Lemma 19.21 and (1) \Rightarrow (5) of Theorem 19.37, we get that $\omega^2(\xi_v) = 0$ againsts the assumption that $\omega^2(\xi_v) \neq 0$. This is a contradiction. □

19.8.6. On $\mathcal{I}_2(M)$ for a non orientable 3-manifold. If M is non orientable the structure of $\mathcal{I}_2(M)$ is eventually simpler. Consider the product

$$\Gamma_0(M) = \eta_1(M) \times \mathcal{H}^1(M, \mathbb{Z}/2\mathbb{Z}) \times \mathbb{Z}/2\mathbb{Z}$$

with the twisted group structure given by the operation

$$(\delta, h, a) + (\delta', h', a') := (\delta + \delta' + h \sqcup h', h + h', a + a') .$$

Then we have **[G]**

THEOREM 19.62. *Let M be a non orientable compact connected boundaryless 3-manifold. The map*

$$\psi_0 : \mathcal{I}_2(M) \rightarrow \Gamma_0(M), \quad \psi_0([S, f]_i) = ([\Sigma_f], [f], \chi_{(2)}(S))$$

is a well defined semigroup isomorphism (hence $\mathcal{I}_2(M)$ is eventually a group).

To a large extent the proof is an adaptation of the above one when M is orientable, but one has to face several differences (the existence of knots in M with solid Klein bottle tubular neighbourhoods, the absence of framing of M and so on). The basic reason for the final simpler form of $\mathcal{I}_2(M)$ is that the subgroup of the immersed surfaces in a 3-ball of M is a quotient of $\mathcal{I}_2(\mathbb{R}^3) \sim \mathbb{Z}/8\mathbb{Z}$ isomorphic to $\mathbb{Z}/2\mathbb{Z}$. For $\mathcal{I}_2(\mathbb{R}^3)$ is generated by the Boy surface B and as M is non orientable there is a diffeotopy of M which sends a 3-disk of M containing a copy of B into itself reversing the orientation; hence $[B]_i = [\bar{B}]_i = -[B]_i$.

19.9. Tear and smooth-rational equivalences

The notion of blowing up a manifold along a smooth centre has been defined in Section 7.10.1. In Section 15.5 we have interpreted the stable equivalence between surfaces in terms of blowing up of points which are the only possible smooth centres in such a case. If M is now a compact boundaryless 3-manifold besides the points we have also any link of knots in M as a possible smooth centre. In this section, referring to [BM], we widely study some equivalence relations generated by blowing up 3-manifolds along smooth centres (and diffeomorphisms). We will discuss also applications of this study to the so called *3-dimensional Nash's rationality conjecture*.

19.9.1. 3-dimensional blowing-up-or-down. We denote by \mathcal{M}_3 the class of all compact connected boundaryless 3-manifolds. Let M be such a manifold. A possible smooth centre X of a blow up

$$\pi : B(M, X) \rightarrow M$$

is either a finite set of points or a link of a finite number of pairwise disjoint knots in M , $L = K_1 \cup \dots \cup K_s$. We know that $D_X := \pi^{-1}(X)$ is a hypersurface of $B(M, X)$ called the *exceptional hypersurface*. We also say that M is obtained by *blowing down* $\tilde{M} := B(M, X)$ along the hypersurface D_X .

For simplicity let us analyse connected centres. A connected smooth centre in M is either a point or a knot K . We know that the effect of blowing up one point consists (up to diffeomorphism) in performing a connected sum $M \# \mathbf{P}^3(\mathbb{R})$, the exceptional hypersurface being a one-side projective plane $\mathbf{P}^2(\mathbb{R})$ that is a projective plane with oriented tubular neighbourhood.

As M is not necessarily orientable then a knot K either preserves the orientation, that is it has a solid torus tubular neighbourhood in M , or it reverses the orientation, that is it has a solid Klein bottle tubular neighbourhood in M . In the first case the exceptional hypersurface D_K in $B(M, K)$ is a one-side torus. In the second it is a one-side Klein-bottle. Reciprocally we have

PROPOSITION 19.63. *Let \tilde{M} be in \mathcal{M}_3 and Y be a hypersurface of \tilde{M} which is either a projective plane with oriented tubular neighbourhood, a one-side torus or a one-side Klein bottle. Then there exists M in \mathcal{M}_3 and a smooth centre $X \subset M$ such that $\tilde{M} = B(M, X)$ and $Y = D_X$.*

Proof : If $Y \sim \mathbf{P}^2(\mathbb{R})$ with orientable tubular neighbourhood $N(K)$, then $N(K) \sim \mathbf{P}^3(\mathbb{R}) \setminus \text{Int}(B)$ where B is a 3-ball. Then $\tilde{M} = M \# \mathbf{P}^3(\mathbb{R})$ for some M so that \tilde{M} is the blow up of M at a point.

The standard model of a tubular neighbourhood of a one-side torus is obtained by taking the blow up

$$\pi : N := B(D^2 \times S^1, \{0\} \times S^1) \rightarrow D^2 \times S^1 .$$

Denote by $p : D^2 \times S^1 \rightarrow S^1$ the natural projection, $D_x^2 = p^{-1}(x)$. N is diffeomorphic to $\mathcal{M} \times S^1$, \mathcal{M} being a Möbius strip, with natural projection $\tilde{p} : \mathcal{M} \times S^1 \rightarrow S^1$ such that $\tilde{p} = p \circ \pi$; for every $x \in S^1$, $\mathcal{M}_x = \tilde{p}^{-1}(x) = B(D_x^2, \{0\} \times \{x\})$. On the torus $\partial N \sim \partial D^2 \times S^1$ it is defined the involution τ which restricts to the antipodal one on every ∂D_x^2 . N (and coherently every \mathcal{M}_x) can be identified with the mapping cylinder of τ . The exceptional hypersurface is the torus $D = s_0 \times S^1$, where $s_0 = \pi^{-1}(\{0\} \times \{x_0\})$ and x_0 is a base point on S^1 . The mapping cylinder structure realizes also N as being a tubular neighbourhood of D , endowed with its projection $q : N \rightarrow D$. The restriction of q to ∂N is a fibred double covering of D .

If $Y \subset \tilde{M}$ is a one-side torus, there are in fact *several ways* to fix a parametrization

$$\phi : (N, D) \rightarrow (N(Y), Y)$$

so that the blow down $\pi : N \rightarrow D^2 \times S^1$ gives rise to a blow down $\pi : \tilde{M} \rightarrow M$, for some M in \mathcal{M}_3 , where $(N(Y), Y)$ is mapped onto $(N(K), K)$, K is a knot in M which preserves the orientation and $N(K)$ is a tubular neighbourhood of K in M . To do it assume that $N(Y)$ is constructed by using a normal line bundle ξ on Y in \tilde{M} . By hypothesis, the Euler class $\omega^1(\xi) \neq 0$. Fix any fibration \mathcal{F}_s of Y by smooth circles parallel to a circle s such that $\omega^2(\xi) \sqcup [s] \neq 0$. This means that the restriction of the line bundle ξ to s is not trivial. Then there is a diffeomorphism $\phi : (N, D) \rightarrow (N(Y), Y)$ such that the fibration \mathcal{F}_{s_0} of D by the circles parallel to s_0 is mapped to the fibration \mathcal{F}_s . To see it we can transfer the question to the above standard model. The fibration \mathcal{F}_{s_0} of D lifts by the projection q to the fibration by meridians of $\partial N \sim \partial D^2 \times S^1$; set $m_0 = \partial D^2 \times \{x_0\}$ and denote by $\tilde{\mathcal{F}}_{m_0}$ such fibration. Fix on D another fibration \mathcal{F}_s parallel to an s with the properties fixed above. This lifts by the projection q to a fibration $\tilde{\mathcal{F}}_{\tilde{s}}$ of ∂N by circles parallel to a \tilde{s} such that $[\tilde{s}] = [m_0] \in \eta_1(\partial N)$. Moreover, by construction $\tilde{\mathcal{F}}_{\tilde{s}}$ is invariant by the involution τ . We claim that, possibly up to isotopy of s , there is a diffeomorphism h of the torus ∂N which sends $\tilde{\mathcal{F}}_{m_0}$ to $\tilde{\mathcal{F}}_{\tilde{s}}$ and extends to a diffeomorphism of (N, D) sending the fibration \mathcal{F}_{s_0} of D to \mathcal{F}_s . In such a case it is easy to see that the topological space obtained by collapsing every fibre of \mathcal{F}_s to one point results from another blow down of (N, D) obtained by the *flip* $\mathcal{F}_{s_0} \rightarrow \mathcal{F}_s$ of fibrations of the exceptional hypersurface D . To justify the claim, let us identify ∂N with $\mathbb{R}^2/\mathbb{Z}^2$, endowed with “linear” coordinates such that the line $\{y = 0\}$ is mapped onto $l_0 = \{p_0\} \times S^1$, while the line $\{x = 0\}$ is mapped onto m_0 and the involution can be expressed as $\tau(x, y) = (x, y + 1/2)$; up to isotopy a generic diffeomorphism in the form $h(x, y) = (ax + by, cx + dy)$, with the coefficients belonging to a matrix in $GL(2, \mathbb{Z})$. Under our hypotheses, $h(0, y) = (by, dy)$ where b is even and d is odd, so that clearly $h \circ \tau = \tau \circ h$ and this is enough to conclude.

The discussion for the one-side Klein bottle is similar (however, see Remark 19.66).

□

19.9.2. Tears and Dehn surgery. The possibility to *flip the fibrations of an exceptional hypersurface* hence to modify the corresponding blowing down (sometimes this modification is called a *flop*), suggests a way to possibly modify the topology of 3-manifolds.

DEFINITION 19.64. Let M be in \mathcal{M}_3 and $L = K_1 \cup \dots \cup K_s$ be a link in M whose constituent knots preserve the orientation. We say that M' in \mathcal{M}_3 is obtained from M by a *tear along* L , if up to diffeomorphism there is blow down flop

$$M \leftarrow B(M, L) \rightarrow M'$$

associated to a system of flips of fibrations of the exceptional hypersurfaces D_{K_i} as in the proof of Proposition 19.63. In other words $(B(M, L), D_L) = (B(M', L'), D_{L'})$ for some link $L' = K'_1 \cup \dots \cup K'_s$ in M' whose constituent knots preserve the orientations.

LEMMA 19.65. *Tears define an equivalence relation called tear equivalence and we write $M \sim_t M'$.*

Proof : If we move a centre by an ambient isotopy, the result of a blowing up does not change up to diffeomorphism preserving the exceptional hypersurfaces. Given a tear from M to M' (with associated links L in M and L'_1 in M') and a tear from M' to M'' (with associated links L'_2 in M' and L'' in M''), by transversality we can assume that $L'_1 \cap L'_2 = \emptyset$, hence there is a copy of L'_2 in M , and a copy of L'_1 in M'' so that $L \cup L'_2$ and $L'' \cup L'_1$ are links in M and M'' respectively, supporting a tear from M to M'' . This proves that the relation is transitive. It is trivially reflexive and symmetric.

□

REMARK 19.66. A priori one would consider also tear along knots which reverse the orientation. However, for such a tear $M \leftarrow \tilde{M} \rightarrow M'$, it turns out that $M \sim M'$; this happens because on a Klein bottle there is only one isotopy class of smooth circles with annular tubular neighbourhood. So we consider only tears along knots preserving the orientation.

It is convenient to rephrase tears in terms of more usual modifications performed on 3-manifolds. As above, let M be in \mathcal{M}_3 , $L = K_1 \cup \dots \cup K_s$ be a link in M with constituent knots preserving the orientation. Let $N(L) = N(K_1) \amalg \dots \amalg N(K_s)$ be a tubular neighbourhood of L in M . Consider the manifold with s toric boundary components

$$N := M \setminus \text{Int}N(L).$$

We say that M' is obtained by a *Dehn surgery* of M along L if, up to diffeomorphism, it is obtained by gluing back every $N(K_i)$ to N along the torus $\partial N(K_i)$ by means of a diffeomorphism $h_i : \partial N(K_i) \rightarrow \partial N(K_i)$, $i = 1, \dots, s$. $L \subset N(L)$ determines a link $L' = K'_1 \cup \dots \cup K'_s$ in M' and the identity map of N extends to a diffeomorphism $\psi : M \setminus L \rightarrow M' \setminus L'$. If m_i is a meridian of $\partial N(K_i)$, then $h_i(m_i) = s_i$ is a smooth circle on $\partial N(K_i)$. The fibration of $\partial N(K_i)$ by meridians parallel to m_i is mapped by h_i to a fibration by circles parallel to s_i . These are meridians of a tubular neighbourhood of L' in M' . If every s_i is a *longitude* of $\partial N(K_i)$ then M' is obtained from M by an ordinary surgery already considered above. So Dehn surgery generalizes the ordinary surgery associated to 4-dimensional triads. The diffeomorphism ϕ extends to a diffeomorphism $\phi : M \rightarrow M'$ if and only if every s_i is a meridian of $\partial N(K_i)$.

Now, up to diffeomorphism, $B(M', L')$ is obtained from $B(M, L)$ by gluing back every $B(N(K_i), K_i)$ to N along the torus $\partial N(K_i)$ by means of the same diffeomorphism $h_i : \partial N(K_i) \rightarrow \partial N(K_i)$, $i = 1, \dots, s$, as before.

DEFINITION 19.67. We say that a Dehn surgery *lifts to a tear* if the diffeomorphism $\tilde{\phi} : B(M, L) \setminus D_L \rightarrow B(M', L') \setminus D_{L'}$ which lifts $\phi : M \setminus L \rightarrow M' \setminus L'$, extends to a diffeomorphism $\tilde{\phi} : B(M, L) \rightarrow B(M', L')$, preserving the exceptional hypersurface.

We have

PROPOSITION 19.68. *A Dehn surgery from M to M' lifts to a tear if and only if for every $i = 1, \dots, s$, $[s_i] = [m_i] \in \eta(\partial N(K_i)) = \mathcal{H}^1(\partial N(K_i); \mathbb{Z}/2\mathbb{Z})$.*

Proof : The condition is necessary because the meridians generates the kernel of the unoriented bordism morphism induced by the inclusions $\partial N(K_i) \rightarrow N(K_i)$. The other implication rephrases the proof of Proposition 19.63.

□

With respect to ordinary surgery we have the following immediate corollary.

COROLLARY 19.69. *Let M', M'' be obtained by ordinary (longitudinal) surgery on M along a same link $L = \cup_i K_i$ with different normal framings $\{\mathfrak{f}'_i\}$ and $\{\mathfrak{f}''_i\}$ respectively. Let $L' \subset M'$ and $L'' \subset M''$ be the links corresponding to L respectively. Then M'' is obtained (up to diffeomorphism) from M' by a tear of the form*

$$M' \leftarrow B(M', L') = B(M'', L'') \rightarrow M''$$

if and only if every \mathfrak{f}'_i differs from \mathfrak{f}''_i by an even number of twists.

□

Hence tear equivalence can be considered as a specialization of the equivalence relation generated by Dehn surgery. As this last extends ordinary surgery and

preserves orientability, then we already know that *being or not orientable is a complete invariant for Dehn surgery equivalence*. We are going to see that this is no longer true for tear equivalence. We refine the ‘orientable/non-orientable’ partition $\mathcal{M}_3 = \mathcal{M}_3^+ \amalg \mathcal{M}_3^-$ so that we eventually have three *types*, completely determined by the behaviour of $\omega^1(*)$:

- $\omega^1(M) = 0 \in \mathcal{H}^1(M; \mathbb{Z}/2\mathbb{Z})$, that is it is *orientable*;
- $\omega^1(M) \neq 0$ and $\omega^1(M)^2 := \omega^1(M) \sqcup \omega^1(M) = 0$, then we say that M is *weakly non orientable*, that is $M \in \mathcal{M}_3^w$.
- $\omega^1(M) \neq 0$ and $\omega^1(M)^2 := \omega^1(M) \sqcup \omega^1(M) \neq 0$, then we say that M is *strongly non orientable*, that is $M \in \mathcal{M}_3^s$.

Characteristic surfaces: If M is non orientable, every hypersurface F which represents $\omega^1(M)$ is called a *characteristic surface* of M . We can assume that F is connected and it is necessarily orientable: the boundary $\partial N(F)$ of a tubular neighbourhood is connected and orientable as it is the boundary of the orientable manifold $M \setminus \text{Int}N(F)$; the projection of $\partial N(F)$ to F is 2 : 1 and every orientation on $\partial N(F)$ descends to F .

We have

PROPOSITION 19.70. *Let $M \sim_t M'$ be realized by a tear*

$$M \xleftarrow{\pi} B(M, L) = \tilde{M} = B(M', L') \xrightarrow{\pi'} M', \quad L = \cup_{i=1}^s K_i .$$

1) *For every $j = 0, \dots, 3$, $\pi^* : \mathcal{H}^j(M; \mathbb{Z}/2\mathbb{Z}) \rightarrow \mathcal{H}^j(\tilde{M}; \mathbb{Z}/2\mathbb{Z})$ is an injective homomorphism and the similar fact holds for π' .*

2) $\mathcal{H}^1(\tilde{M}; \mathbb{Z}/2\mathbb{Z}) \sim \mathcal{H}^1(M; \mathbb{Z}/2\mathbb{Z}) \oplus (\mathbb{Z}/2\mathbb{Z})^s$ where the last factor is generated by the components D_{K_i} of D_L ; $\mathcal{H}^2(M; \mathbb{Z}/2\mathbb{Z}) \sim \mathcal{H}^2(M; \mathbb{Z}/2\mathbb{Z}) \oplus (\mathbb{Z}/2\mathbb{Z})^s$ where the last factor is generated by the fibres \mathcal{M}_i of the fibrations $\mathcal{M} \times K_i \rightarrow K_i$ of D_{K_i} ; similarly for π' .

3) *For every $j = 0, \dots, 3$, there is a natural isomorphism*

$$h_j : \mathcal{H}^j(M; \mathbb{Z}/2\mathbb{Z}) \rightarrow \mathcal{H}^j(M'; \mathbb{Z}/2\mathbb{Z})$$

such that $(\pi')^ \circ h^j = \pi^*$. Moreover $h_1(\omega^1(M)) = \omega^1(M')$ and for every $\alpha \in \mathcal{H}^1(M; \mathbb{Z}/2\mathbb{Z})$, $h^2(\alpha \sqcup \omega^1(M)) = h^1(\alpha) \sqcup \omega^1(M')$.*

4) *M, M' are of the same type.*

Proof : Let us justify (1) – (3). For every j , every class in $\mathcal{H}^j(M; \mathbb{Z}/2\mathbb{Z})$ can be represented by an embedded proper $(3-j)$ -submanifold S transverse to the link L . The corresponding class in $\mathcal{H}^j(\tilde{M}; \mathbb{Z}/2\mathbb{Z})$ is represented by the strict transform \tilde{S} of S via the blow up. If $j = 2, 3$ in fact \tilde{S} is mapped diffeomorphically onto S by π . If $j = 0$, $\tilde{S} = \tilde{M}$. If $j = 1$, then $\tilde{S} = B(S, S \pitchfork L)$. As for (2) notice that $\mathcal{M}_i \bullet D_{K_j} = \delta_{i,j}$. As for (3) consider the diffeomorphism

$$\phi : M \setminus L \rightarrow M' \setminus L' ,$$

If $j = 2, 3$, then h_j is determined by the diffeomorphism $S \sim \phi(S)$. If $j = 0$, then $h_0([M]) = [M']$, and notice that $[\tilde{M}, \pi] = [M]$, $[\tilde{M}, \pi'] = [M']$. If $j = 1$, then S is a hypersurface transverse to L . Then $S \setminus \text{Int}N(L)$ is sent diffeomorphically onto \tilde{S}' properly embedded into $M' \setminus \text{Int}N(L')$; as ϕ preserves the class of meridians mod (2), then \tilde{S}' can be completed to a boundaryless hypersurface S' transverse to L' . This geometric correspondence $S \leftrightarrow S'$ induces h_1 . If S is a characteristic surface of M , as the constituent knots of L preserve the orientation, we can assume that $S \cap L = \emptyset$, so that the diffeomorphic surface $S' = \phi(S)$ does not intersect L' and is a characteristic surface of M' . The last statements of (3) follow. Clearly (4) is a corollary of the other items. □

In what follows we will say that S' obtained from S as in the above proof is obtained by *darning* S (with respect to the given tear).

REMARK 19.71. One would wonder about a graded ring isomorphism in above statement (3). But this is not true. For example $S^1 \times S^2$ and $\mathbf{P}^3(\mathbb{R})$ can be obtained by ordinary surgery along an unknot $K \subset \mathbb{R}^3 \subset S^3$ with the standard even normal framing f_0 and the framing which differs from it by two twists, respectively. By Corollary 19.69, they are connected by a tear, but their $\mathbb{Z}/2\mathbb{Z}$ -cobordism rings are different.

19.9.3. *rs-equivalence.* We define now a coarser equivalence relation generated by blowing-up-or-down.

DEFINITION 19.72. Let M, M' be in \mathcal{M}_3 . We say that, *up to diffeomorphism, M' is obtained from M by a finite chain of blowing-up-or-down* if there is a finite chain of the form:

$$M \rightarrow M_0 \leftrightarrow M_1 \leftrightarrow M_2 \leftrightarrow \cdots \leftrightarrow M_n \leftarrow M'$$

where:

- (1) Every M_i is in \mathcal{M}_3 ;
- (2) the right and left arrows are diffeomorphisms;
- (3) for every $i \neq n$, $M_i \leftrightarrow M_{i+1}$ either is a a blow up along a smooth centre

$$M_i \leftarrow M_{i+1} = B(M_i, C_i)$$

or a blow-up

$$M_i = B(M_{i+1}, Z_{i+1}) \rightarrow M_{i+1}$$

so that M_{i+1} is obtained by a *blow down* of M_i .

This defines another equivalence relation called *smooth-rational equivalence* which extends the diffeomorphism one and also the tear equivalence. We write $M \sim_{sr} M'$. Note that noone of the tear invariants pointed out in Proposition 19.70 persists for the *sr*-equivalence.

Our goals are to fully determine the quotient set of $\mathcal{M}_3 \bmod \sim_{sr}$ or $\bmod \sim_t$. Tear equivalence preserves the type so we can split the study of $\mathcal{M}_3 \bmod \sim_t$ type by type.

The results for $\mathcal{M}_3^+ \bmod \sim_t$ and for $\mathcal{M}_3 \bmod \sim_{sr}$ are easy to state:

THEOREM 19.73. *For every M, M' in \mathcal{M}_3^+ , then $M \sim_t M'$ if and only if $\dim \mathcal{H}^1(M; \mathbb{Z}/2\mathbb{Z}) = \dim \mathcal{H}^1(M'; \mathbb{Z}/2\mathbb{Z})$. If $\dim \mathcal{H}^1(M; \mathbb{Z}/2\mathbb{Z}) = h$, then*

$$M \sim_t S^3 \# h\mathbf{P}^3(\mathbb{R}) .$$

PROPOSITION 19.74. *For every M in \mathcal{M}_3^- there exists $M' \in \mathcal{M}_3^+$ such that $M \sim_{sr} M'$.*

As a corollary we have

THEOREM 19.75. *For every M in \mathcal{M}_3 , $M \sim_{sr} S^3$.*

Proof : By assuming Theorem 19.73 and Proposition 19.74. If M is in \mathcal{M}_3^+ , then the result follows immediately from Theorem 19.73 as $S^3 \# h\mathbf{P}^3(\mathbb{R})$ is obtained by blowing-up S^3 at h points. If $M \in \mathcal{M}_3^-$, Proposition 19.74 reduces it to the orientable case. □

The structure of $\mathcal{M}_3^- \bmod \sim_t$ is intrinsically more complicated, we will face it later.

19.9.4. Disorientated surfaces and weakly trivial knots. Let N be a compact 3-manifold with possibly non empty boundary ∂N . A connected properly embedded surface F in N is said *disorientated* if it is non orientable and has an orientable neighbourhood in N .

Let M be in \mathcal{M}_3 , and $K \subset M$ be a knot which preserves the orientation with a tubular neighbourhood $N(K)$. Then K is said *weakly trivial* if there exists a longitude l on $\partial N(K)$ which bounds a disorientated surface F properly embedded into $M \setminus \text{Int}N(K)$.

The notion of tear makes sense also for a manifold with boundary N , provided that the supporting link is contained in the interior of N . The following proposition shows tear's power to simplify disorientated hypersurfaces and eventually the topology of 3-manifolds.

PROPOSITION 19.76. *Let $S \subset N$ be a disorientated hypersurface. Assume that S has at most two boundary components. Then there are: a link $L \subset \text{Int}(S) \subset \text{Int}(N)$ with constituent knots preserving the orientation, a tear*

$$N \leftarrow B(N, L) = \tilde{N} = B(N', L') \rightarrow N'$$

and a surface $S' \subset N'$ obtaining by darning S (with respect to the tear) such that:

- (1) If S is boundaryless then S' is a disorientated projective plane.
- (2) If ∂S is connected then S' is a disk properly embedded in N'
- (3) If ∂S has two components, then S' is a two-sides annulus properly embedded in N' .

Proof: S is diffeomorphic to the connected sum of s copies of $\mathbf{P}^2(\mathbb{R})$, $s \geq 1$, from which we have removed k disjoint open 2-disks, either $k = 0, 1, 2$. Let $L = K_1 \cup \dots \cup K_s$ be formed by the cores of s pairwise disjoint Möbius strips \mathcal{M}_i embedded in S . Each K_j reverses the orientation of S and preserves the orientation of N (because S has an orientable neighbourhood). Then $[\partial \mathcal{M}_i]$ is a meridian of $\partial N(K_i) \bmod (2)$ and we can consider the corresponding tear $N \leftarrow B(N, L) = B(N', L') \rightarrow N'$. Then every K_i collapses to one point in a darning surface S' properly embedded in N' with orientable neighbourhood. If $k = 0$ then S' is a 2-sphere; in order to get a disorientated $\mathbf{P}^2(\mathbb{R})$ it is enough to remove from L one constituent knot. In the other two cases we get either a disk or an annulus. □

COROLLARY 19.77. *For every $M \in \mathcal{M}_3$ there is a chain of the form*

$$M \rightarrow M_0 \leftrightarrow M_1 \leftrightarrow \dots \leftrightarrow M_n \leftarrow M'$$

such that:

- (1) Every M_i is in \mathcal{M}_3 , the right and left arrows being diffeomorphisms;
- (2) $\mathcal{H}^1(M'; \mathbb{Z}/2\mathbb{Z})$ is generated by $\omega^1(M')$;
- (3) For every $i \neq n$, $M_i \leftrightarrow M_{i+1}$ either is:
 - a tear;
 - a blow up $M_i = B(M_{i+1}, x_0) \rightarrow M_{i+1}$ at a point of M_{i+1} ;
 - a blow up $M_i = B(M_{i+1}, K) \rightarrow M_{i+1}$ along a smooth knot of M_{i+1} which preserves the orientation.

Proof: If M already verifies (2), then take $M' = M$. Otherwise there is a hypersurface S , such that $[S] \neq 0 \in \mathcal{H}^1(M; \mathbb{Z}/2\mathbb{Z})$ and is not a characteristic surface of M . We can assume that S is connected and that there is a characteristic surface F such that either

- $S \cap F = \emptyset$, that is $S \subset M \setminus N(F)$ for a small tubular neighbourhood of F ;
- $S \pitchfork F$ along a knot $K \subset S$ which does not divide it.

- In both cases $S \setminus \text{Int}N(F)$ is properly embedded into $M \setminus \text{Int}N(F)$, has oriented neighbourhood therein, and there is a smooth circle $C \subset M \setminus \text{Int}N(F)$ with non trivial intersection number mod (2) with $S \setminus \text{Int}N(F)$. By adding an embedded 1-handle along a suitable arc of C , we can also assume that $S \setminus \text{Int}N(K)$ is disorientated. Now, if S is disjoint from F , by Proposition 19.76 there is a tear which converts S into a disorientated projective plane; this can be considered as the exceptional hypersurface of a blow up of a point. In the other case there is a tear converting $S \setminus \text{Int}N(F)$ into an annulus; together with $S \cap N(F)$ they form a one-side torus which can be considered as the exceptional hypersurface of a blow up along a knot.

□

COROLLARY 19.78. *If M is orientable and $\dim \mathcal{H}^1(M; \mathbb{Z}/2\mathbb{Z}) = h$, then*

$$M \sim_t \tilde{M}$$

where

$$\tilde{M} = h\mathbf{P}^3(\mathbb{R}) \# M'$$

and $\mathcal{H}^1(M'; \mathbb{Z}/2\mathbb{Z}) = 0$.

Proof : As M is orientable $\omega^1(M) = 0$; hence the statement and the proof of Corollary 19.77 tell us that $\mathcal{H}^1(M'; \mathbb{Z}/2\mathbb{Z}) = 0$ and that only blow up of points does occur. As up to isotopy a point misses any possible already present exceptional hypersurface, tears and blowing up of points commute and the corollary follows.

□

COROLLARY 19.79. *Let M and M' in \mathcal{M}_3 be such that*

$$\mathcal{H}^1(M; \mathbb{Z}/2\mathbb{Z}) = \mathcal{H}^1(M'; \mathbb{Z}/2\mathbb{Z}) = 0 .$$

Assume that M' is obtained from M by an ordinary (longitudinal) surgery of M along a weakly trivial knot $K \subset M$. Then $M \sim_t M'$.

Proof : By Proposition 19.76 there is a tear from M to M_1 converting K to a genuine trivial knot $K_1 \subset M_1$. So up to tear equivalence, we can assume that M' is obtained from M by an ordinary surgery along a trivial knot K . As they have both vanishing \mathcal{H}^1 the normal framing \mathfrak{f} of this surgery must be odd with respect to the framing \mathfrak{f}_0 determined by a collar of K in a spanning 2-disk. On the other hand M is diffeomorphic to the manifold obtained by using the framing \mathfrak{f}_1 which differs from \mathfrak{f}_0 by one twist. Hence by Corollary 19.69, there is a tear from M to M' .

□

As a further corollary we can prove Proposition 19.74, which we state again

For every M in \mathcal{M}_3^- there exists $M' \in \mathcal{M}_3^+$ such that $M \sim_{sr} M'$.

Proof : Assume that M has a connected characteristic surface F of genus $g + 1 > 1$. We are going to show that $M \sim_{sr} M'$ such that M' either has a characteristic surface F' of genus g if $g > 0$ or it is orientable. Clearly this will achieve the result by induction on g . First we can assume that F is one-side in M . In fact let $K \subset F$ be a smooth circle which does not divide F . Then the strict transform \tilde{F} of F in $B(M, K)$ is a one-side characteristic surface of the same genus. If F is a one-side torus then it is the exceptional hypersurface of a blow down to an orientable M' and we have done. If $g > 1$, there is a smooth circle C on F which divides it by a one-side torus T_0 with one hole, and a bilateral surface S_0 of genus $g - 1$ with one hole. By adding an embedded 1-handle as in the proof of Corollary 19.77, we can modify S_0 far from C and make it desorientated. Then by Proposition 19.76 there is a tear from M to say M_1 which convert S_0 to a 2-disk so that C becomes a trivial knot in M_1 . The manifold M_2 obtained by ordinary

surgery along C with normal framing given by a tubular neighbourhood of C in F is tear equivalent to $M_1 \# \mathbf{P}^3(\mathbb{R})$, hence it is sr -equivalent to M_1 hence to M . We conclude by noticing that a characteristic surface of M_2 is given by the disjoint union of a surface of genus g and a one-side torus which again can be considered as the exceptional hypersurface of a blow down. \square

19.9.5. $\mathcal{M}_3^+ \bmod \sim_t$ and $\mathcal{M}_3 \bmod \sim_{sr}$. We are ready to prove Theorems 19.73 and 19.75. Thanks to Corollary 19.79 and Proposition 19.74, it will enough to prove the following

LEMMA 19.80. *For every M in \mathcal{M}_3 such that $\mathcal{H}^1(M; \mathbb{Z}/2\mathbb{Z}) = 0$, there exists a sequence $S^3 = M_0, M_1, \dots, M_n \sim M$, such that*

- (1) *For every M_i , $\mathcal{H}^1(M_i; \mathbb{Z}/2\mathbb{Z}) = 0$;*
- (2) *M_{i+1} is obtained from M_i by an ordinary surgery along a weakly trivial knot $K_{i+1} \subset M_i$.*

Proof: We use some notions that we will develop in Chapter 20, Section 20.2.1. Here we outline the main points. We know that $S^3 \sim_\sigma M$, that is there is a triad (W, S^3, M) with a handle decomposition made by 2-handles only, so that M is obtained by longitudinal surgery along a framed link $L = \cup_i K_i$ in S^3 . The framing \mathfrak{f}_i is encoded by an integer which express the number of twists with respect to the framing given by the collar of K_i in a Seifert surface. The intersection form of $\mathcal{H}^2(W; \mathbb{Z}/2\mathbb{Z})$ is represented by the linking matrix mod (2) of this framed link L , so that along the diagonal we have the reduction mod (2) of the above integers. As $\mathcal{H}^1(M; \mathbb{Z}/2\mathbb{Z}) = 0$ then the intersection form is non degenerate. Possibly performing an elementary blow-up move (Section 19.4.1), we can also assume that the form is not totally isotropic, hence it has an orthogonal basis (see Section 15.1). By realizing such a change of basis by handle sliding, we get that every K_i is the boundary of a surface S_i disjoint from the rest of the link, and the new normal framings are odd. So the knot K_{i+1} is weakly trivial in the manifold M_i obtained by the surgery along the partial framed link $K_1 \cup \dots \cup K_i$. \square

19.9.6. $\mathcal{M}_3^- \bmod \sim_t$. This is more demanding. We will give exhaustive statements. For detailed proofs a curious reader is addressed to [BM].

We can manage type by type. For \mathcal{M}_3^s the statement is simpler; alike the orientable case, the necessary conditions of Proposition 19.70 are also sufficient.

THEOREM 19.81. *Let M, M' be strongly non orientable. Then $M \sim_t M'$ if and only if for every $j = 0, \dots, 3$, there is a natural isomorphism*

$$h_j : \mathcal{H}^j(M; \mathbb{Z}/2\mathbb{Z}) \rightarrow \mathcal{H}^j(M'; \mathbb{Z}/2\mathbb{Z})$$

such that $h_1(\omega^1(M)) = \omega^1(M')$ and for every $\alpha \in \mathcal{H}^1(M; \mathbb{Z}/2\mathbb{Z})$, $h^2(\alpha \sqcup \omega^1(M)) = h^1(\alpha) \sqcup \omega^1(M')$. \square

For weakly non orientable manifolds another tear invariant comes up.

We begin with a construction that makes sense for every orientable compact boundaryless surface S embedded into any M in \mathcal{M}_3 . Consider the subspace of $\eta_1(S)$ formed by the 1-boundary in M , that is

$$\mathcal{B}(S, M) = \ker i_*$$

where $i : S \rightarrow M$ is the inclusion. Let $\alpha \in \mathcal{B}(S, M)$. Then $\alpha = [c]$ for some smooth circle c on S . By hypothesis, c bounds a *membrane* $\mathfrak{M} \subset M$: by definition \mathfrak{M} is a compact surface embedded in M , such that $c = \partial\mathfrak{M}$, and moreover \mathfrak{M} is in “general

position" with respect to S ; this means that $S \pitchfork \text{Int}(\mathfrak{M})$ and $S \cap \mathfrak{M}$ is the union $c \cup d$ where d is a smooth curve properly embedded in S (i.e. $\partial d = \cap \partial \mathfrak{M}$). Tubular neighbourhoods of d , $N(d, S)$ and $N(d, \mathfrak{M})$ in S and \mathfrak{M} respectively, coincide at ∂d along a tubular neighbourhood of $\partial d = d \cap c$ in c . Then along the abstract double $D(d) = d_+ \cup d_-$ of d we can define a band $N(D(d))$ equal to $N(d, S)$ on d_+ , equal to $N(d, \mathfrak{M})$ on d_- glued by the identity on $\partial d_+ = \partial d_-$. Then we can define by the self-intersection of $D(d)$ in $N(D(d))$

$$\rho_{\mathfrak{M}}(c) = D(d) \bullet D(d) \in \mathbb{Z}/2\mathbb{Z} .$$

We can pose the question under which hypotheses this construction *well defines* a homomorphism

$$\rho_S : \mathcal{B}(S, M) \rightarrow \mathbb{Z}/2\mathbb{Z}, \rho(\alpha) = \rho_{\mathfrak{M}}(c), \alpha = [c] .$$

This is widely discussed in [BM]. Here we are interested to the application of this construction to a characteristic surface F of M in \mathcal{M}_3^- . We have

PROPOSITION 19.82. *Let F be a characteristic surface of the non orientable 3-manifold M . Then $\rho_F : \mathcal{B}(F, M) \rightarrow \mathbb{Z}/2\mathbb{Z}$ is well defined if and only if M is weakly non orientable ($M \in \mathcal{M}_3^w$). In such a case ρ_F is a quadratic enhancement of the restriction, say β , to $\mathcal{B}(F, M)$ of the intersection form on $\eta_1(F)$.*

□

A first point where the vanishing of $\omega^1(M) \sqcup \omega^1(M)$ is relevant is in showing that the value of $\rho_{\mathfrak{M}}(c)$ does not depend on the choice of the membrane \mathfrak{M} . In fact one verifies that:

- (i) $\sigma \sqcup \sigma \sqcup \omega^1(M) + \sigma \sqcup \omega^1(M) \sqcup \omega^1(M) = 0$ for every $\sigma \in \mathcal{H}^1(M; \mathbb{Z}/2\mathbb{Z})$ if and only if $\omega^1(M) \sqcup \omega^1(M) = 0$;
- (ii) given two membranes \mathfrak{M} and \mathfrak{M}' of c , $\tau = \mathfrak{M}' \cup \mathfrak{M}$ define a cycle mod (2) in M and ones verifies that

$$\rho_{\mathfrak{M}'} - \rho_{\mathfrak{M}} = [\tau] \sqcup [\tau] \sqcup \omega^1(M) + [\tau] \sqcup \omega^1(M) \sqcup \omega^1(M) .$$

This is the first step to show that $\rho(c)$ only depends on the class $[c] \in \eta_1(F)$.

Let $M \in \mathcal{M}_3^w$, F , ρ_F , β be as in the above proposition. In general β is degenerate, that is its radical $\mathcal{B}(F, M)^\perp \neq \{0\}$. Then there are two possibilities:

- $\rho_F \neq 0$ on $\mathcal{B}(F, M)^\perp$.
- $\rho_F = 0$ on $\mathcal{B}(F, M)^\perp$. Set $\hat{\mathcal{B}}(F, M) = \mathcal{B}(F, M)/\mathcal{B}(F, M)^\perp$. Then ρ_F descends to a homomorphism

$$\hat{\rho}_F : \hat{\mathcal{B}}(F, M) \rightarrow \mathbb{Z}/2\mathbb{Z}$$

which is a quadratic enhancement of the non degenerate form $\hat{\beta}$ induced by β ; one can define its *Arf invariant* (see Section 15.6)

$$\delta_F := \delta(\hat{\rho}_F) \in \mathbb{Z}/2\mathbb{Z} .$$

So we can associate to F the symbol

$$\tau_F \in \{\emptyset\} \cup \mathbb{Z}/2\mathbb{Z}$$

where $\tau_F = \emptyset$ if $\rho_F \neq 0$ on $\mathcal{B}(F, M)^\perp$, $\tau_F = \delta_F$ otherwise. We have

PROPOSITION 19.83. *Let F be a characteristic surface of M in \mathcal{M}_3^w . Then*

$$\tau_M := \tau_F$$

is well defined, that is it does not depend on the choice of F such that $[F] = \omega^1(M)$.

□

Hence we have refined the type of weakly non orientable manifolds accordingly with the value of τ_M . Finally we can complete the classification up to tear equivalence.

THEOREM 19.84. *Let M, M' be weakly non orientable. Then $M \sim_t M'$ if and only if for every $j = 0, \dots, 3$, there is a natural isomorphism*

$$h_j : \mathcal{H}^j(M; \mathbb{Z}/2\mathbb{Z}) \rightarrow \mathcal{H}^j(M'; \mathbb{Z}/2\mathbb{Z})$$

such that $h_1(\omega^1(M)) = \omega^1(M')$, for every $\alpha \in \mathcal{H}^1(M; \mathbb{Z}/2\mathbb{Z})$, $h^2(\alpha \sqcup \omega^1(M)) = h^1(\alpha) \sqcup \omega^1(M')$ and moreover, $\tau_M = \tau_{M'}$.

□

Let us give more information about the eventual result. First one finds representatives M of every non orientable tear class endowed with a characteristic surface F with minimal boundary space $\mathcal{B}(F, M)$. For every non orientable M , consider the pairs (M, F) where F is a connected characteristic surface. For every non orientable tear equivalence class α , set

$$g(\alpha) = \min\{g(F); (M, F), M \in \alpha\} .$$

We have

PROPOSITION 19.85. *Let (M, F) be such that $g(F) = g(\alpha)$, $\alpha = [M]_t$. Then the boundary dimension*

$$d(\alpha) := \dim \mathcal{B}(F, M)$$

is well defined (type by type) and we have:

- (1) *If M is strongly non orientable, then $d(\alpha, s) = 0$;*
- (2) *If M is weakly orientable and $\tau_\alpha = \emptyset$, then $d(\alpha, w, \emptyset) = 1$;*
- (3) *If M is weakly orientable and $\tau_\alpha = 0$, then $d(\alpha, w, 0) = 0$.*
- (4) *If M is weakly orientable and $\tau_\alpha = 1$, then $d(\alpha, w, 1) = 2$.*

□

We have given normal representatives for every orientable tear class α , that is $h\mathbf{P}^3(\mathbb{R})$, $h = \dim \mathcal{H}^1(M; \mathbb{Z}/2\mathbb{Z})$, $\alpha = [M]_t$. By elaborating on the minimizing representatives of Proposition 19.85, we get normal representatives also for the non orientable classes. For every non orientable $\alpha = [M]_t$, define type by type the integer

$$h(\alpha, s) = \dim \mathcal{H}^1(M; \mathbb{Z}/2\mathbb{Z}) - 2g(\alpha)$$

$$h(\alpha, w, \tau_\alpha) = \dim \mathcal{H}^1(M; \mathbb{Z}/2\mathbb{Z}) - 2g(\alpha) + d(\alpha, w, \tau_\alpha) .$$

PROPOSITION 19.86. *For every non orientable tear equivalence class α there are explicetely given manifolds $M(\alpha, s)$ or $M(\alpha, w, \tau_\alpha)$ such that either*

$$\alpha = [h(\alpha, s)\mathbf{P}^3(\mathbb{R}) \# M(\alpha, s)]_t$$

or

$$\alpha = [h(\alpha, w, \tau_\alpha)\mathbf{P}^3(\mathbb{R}) \# M(\alpha, w, \tau_\alpha)]_t .$$

□

We have more information about these normal representatives. Let us say that M is *smooth-rational elementary* if it is obtained by means of a tower of blowing up along smooth centres over the standard 3-sphere S^3

$$S^3 \leftarrow M_1 \leftarrow M_2 \leftarrow \dots \leftarrow M_k = M .$$

Then we have

PROPOSITION 19.87. *With the exception of the weakly non orientable class α_0 such that $\dim \mathcal{H}^1(M; \mathbb{Z}/2\mathbb{Z}) = 1$, $\alpha_0 = [M]_t$, and $\tau_{\alpha_0} = 1$, the normal representative of every tear class α is smooth-rational elementary. In the exceptional case, α_0 cannot be represented by any smooth-rational manifold, and for the normal representative say M_{α_0} there is a smooth-rational \tilde{M}_{α_0} and a blow up $\tilde{M}_{\text{alpha}_0} = B(M_{\alpha_0}, x_0) \rightarrow M_{\alpha_0}$, where x_0 is a point.*

19.9.7. On 3-dimensional Nash’s rationality conjecture. By using the classification up to tear equivalence, in [BM] one gives an answer to the so called Nash’s conjecture in three dimensions.

Let us say that a non singular 3-dimensional real algebraic set X is *rational elementary* if it is obtained by a tower of blow up along real algebraic non singular centres over the standard sphere S^3 .

First one proves that every tear equivalence class has an explicitly given rational model which is in fact elementary with one exception. Referring to Proposition 19.87, and using variations of Nash-Tognoli theorem (see Section 17.5.3) we have:

PROPOSITION 19.88. *With the exception of the weakly non orientable class α_0 such that $\dim \mathcal{H}^1(M; \mathbb{Z}/2\mathbb{Z}) = 1$, $\alpha_0 = [M]_t$, and $\tau_{\alpha_0} = 1$, the normal representative of every tear class α can be realized to be a rational elementary real algebraic set Y_α . In the exceptional case, there is*

- a rational algebraic set Y_0 with one singular point y_0 ,
- a homeomorphism $h_0 : Y_0 \rightarrow M_{\alpha_0}$ which is a diffeomorphism on $Y_0 \setminus \{y_0\}$,
- an “algebraic resolution of singularity” $\psi : \hat{Y}_0 \rightarrow Y_0$, such that \hat{Y}_0 is rational elementary and $\psi : \hat{Y}_0 \setminus \psi^{-1}(y_0) \rightarrow Y_0 \setminus \{y_0\}$ is an algebraic isomorphism.

□

Then we have:

THEOREM 19.89. (ii) *For every tear equivalence class $\alpha \neq \alpha_0$, for every $M \in \alpha$, there is a tear from M to Y_α of the form*

$$M \xleftarrow{\sigma} Y_M \xleftarrow{\mathfrak{p}} \tilde{Y}_M = B(Y_\alpha, L_M) \xrightarrow{\pi} Y_\alpha$$

where:

- \tilde{Y}_M is rational elementary obtained by blowing up Y_α along a non singular real algebraic link $L_M \subset Y_\alpha$;
- Y_M is rational with regular 1-dimensional singular set $\text{Sing}(Y_M) = \mathfrak{p}(D_{L_M})$ consisting of a union of non singular circles;
- The surjective algebraic map \mathfrak{p} is a ‘resolution of singularity’, that is

$$\mathfrak{p} : \tilde{Y}_M \setminus D_{L_M} \rightarrow Y_M \setminus \text{Sing}(Y_M)$$

is an algebraic isomorphism between regular Zariski open sets;

- σ is a homeomorphism which restricts to a diffeomorphism on $Y_M \setminus \text{Sing}(Y_M)$ and on $\text{Sing}(Y_M)$;
- $\sigma \circ \mathfrak{p}$ is a smooth blow down.

(iii) *As for $M \in \alpha_0$ we have a similar realization of a tear of the form*

$$M \xleftarrow{\sigma} Y_M \xleftarrow{\mathfrak{p}} \tilde{Y}_M = B(Y_0, L_M) \xrightarrow{\pi} Y_0 \xrightarrow{h_0} M_{\alpha_0}$$

where $L_M \subset R(Y_0)$, and eventually the rational model Y_M of M has a further isolated singular point and admits an algebraic resolution of singularity by means of the rational elementary $B(\hat{Y}_0, \hat{L}_M)$, $\hat{L}_M = \psi^{-1}(L_M)$.

□

So the theorem shows that every M in \mathcal{M}_3 has a *singular* rational algebraic model Y_M with mild controlled singular set which, nevertheless, cannot be avoided

by the specific blow-up-and-down way the model has been constructed. The situation is very similar to what we have done in the case of surfaces (Section 15.5). In the case of surfaces Comessati tells us that for genus greater than 1, the presence of one singular point in a rational model of an orientable surface is not only an accident of the construction, it is intrinsically unavoidable. The same question has been faced for threefolds (see [Ko]); roughly summarizing, one realizes that also in dimension 3, orientable manifolds admitting a non singular rational model are very special. On the other hand, we have the following interesting fact (see [Ko2]):

For every α , for every $M \in \alpha$, there are non singular rational models, provided that one deals with a category of “abstract” algebraic-like varieties (also called Moishezon varieties) which are only locally but not globally isomorphic to ordinary algebraic sets in some \mathbb{R}^n .

In fact in this larger setting also the singular blow down $\mathfrak{p} : \tilde{Y}_M \rightarrow Y_M$ can be realized as the inverse of an algebraic blow up along a non singular centre.

On 4-manifolds

In this chapter we will apply several results established so far to compact 4-manifolds. Similarly to the attitude of Chapter 19 with respect to the geometrization of 3-manifolds, we stress that we will develop a few classical differential/topological themes, in no way (with the exception of a final informative and discursive section) we will touch the study of 4-manifolds by means of *gauge theory* that has dominated the study of 4-manifolds in last decades; for a more up to date treatment of 4-manifolds theory one can refer for example to [Sc]. In particular we will determine Ω_4 , present some instances of “classification of simply connected 4-manifolds up to stabilization”, and Rohlin’s theorem about the signature mod (16) of 4-manifold intersection forms. The intersection form will be indeed the principal player.

We will deal with *oriented* 4-manifolds. M will denote a compact, connected, oriented, boundaryless smooth 4-manifold. By using the notations and the results of Sections 11.4, 13.4 and 13.5 we have that the *intersection form*

$$\sqcup : \mathcal{H}^2(M; \mathbb{Z}) \times \mathcal{H}^2(M; \mathbb{Z}) \rightarrow \mathbb{Z}$$

equivalently

$$\bullet : \mathcal{H}_2(M; \mathbb{Z}) \times \mathcal{H}_2(M; \mathbb{Z}) \rightarrow \mathbb{Z}$$

is symmetric and induces a \mathbb{Z} -linear isomorphism

$$\hat{\phi} : \mathcal{H}^2(M; \mathbb{Z}) \rightarrow \text{Hom}(\mathcal{H}_2(M; \mathbb{Z}), \mathbb{Z}) .$$

Then the free \mathbb{Z} -module $\mathcal{H}^2(M; \mathbb{Z}) = \mathcal{H}_2(M; \mathbb{Z})$ is of finite rank say n , and the intersection form is *unimodular*: for any basis of $\mathcal{H}^2(M; \mathbb{Z})$ the representing matrix A belongs to $GL(n, \mathbb{Z})$ i.e. $|\det A| = 1$. Every class $\alpha \in \mathcal{H}^2(M; \mathbb{Z})$ can be represented by an oriented 2-dimensional proper submanifold F ; $\alpha = [F] = 0$ if and only if F is the boundary of an embedded Seifert hypersurface. Clearly the isometry class of the intersection form is an invariant up to orientation preserving diffeomorphism. We are in a situation formally similar to the case of compact boundaryless surfaces S with respect to the intersection form on the $\mathbb{Z}/2\mathbb{Z}$ -vector space $\eta_1(S; \mathbb{Z}/2\mathbb{Z}) = \mathcal{H}_1(S; \mathbb{Z}/2\mathbb{Z})$. In the case of surfaces we have seen in Chapter 15 that this intersection form contains all relevant information; moreover, there is a perfect parallelism between the abstract algebraic theory of symmetric $\mathbb{Z}/2\mathbb{Z}$ -bilinear forms and its 2-dimensional differential/topological realization. We would try to pursue this analogy as far as possible, obtaining in fact only very partial results.

20.1. Symmetric unimodular \mathbb{Z} -bilinear forms

In analogy to Section 15.1, we face here the question of the classification of finite rank, symmetric, unimodular \mathbb{Z} -bilinear forms up to isometry. It turns out that this abstract classification is complete only for the class of *indefinite forms*, while the *definite* case is a wide largely unknown territory. This is a main difference with respect to the $\mathbb{Z}/2\mathbb{Z}$ -case. For more information and detailed proofs we refer the reader to [MH].

We consider free \mathbb{Z} -modules V of finite rank, endowed with a symmetric unimodular \mathbb{Z} -bilinear form ρ . This means that the \mathbb{Z} -linear map

$$V \rightarrow \text{Hom}(V, \mathbb{Z}), \quad v \rightarrow f_v, \quad f_v : V \rightarrow \mathbb{Z}, \quad f_v(w) = \rho(v, w)$$

is an isomorphism. Equivalently, the symmetric matrix A representing ρ with respect to any basis of V belongs to $GL(n, \mathbb{Z})$, $n = \text{rank} V$, that is $|\det A| = 1$. Isometry is defined in the usual way. Sometimes we will make the abuse of confusing a form with its isometry class. Given (V, ρ) and (V', ρ') we can define the *orthogonal direct sum*

$$(V, \rho) \perp (V', \rho')$$

that is the symmetric unimodular form $\rho \perp \rho'$ on $V \oplus V'$ that restricts to ρ (resp. ρ') on V (V') and such that V and V' are orthogonal to each other.

20.1.1. Some invariants. We point out some isometry invariants besides the rank.

(Signature) By extension of the coefficients $\mathbb{Z} \subset \mathbb{R}$, V becomes a lattice in a \mathbb{R} -vector space $V_{\mathbb{R}}$ so that $\dim V_{\mathbb{R}} = \text{rank} V = n$, and ρ extends to a \mathbb{R} -bilinear non degenerate form $\rho_{\mathbb{R}}$. We know by Sylvester's theorem that a complete isometry invariant of $\rho_{\mathbb{R}}$ is given by the pair of *positivity* and *negativity indices* $(i_+(\rho_{\mathbb{R}}), i_-(\rho_{\mathbb{R}}))$, where $i_{\pm}(\rho_{\mathbb{R}})$ is the maximum of dimensions of \mathbb{R} -linear subspaces of $V_{\mathbb{R}}$ such that the restriction of $\rho_{\mathbb{R}}$ to them is either positive or negative definite. Clearly this pair of indices is also an isometry invariant for the \mathbb{Z} -bilinear form ρ . We set

$$\sigma(\rho) = i_+(\rho_{\mathbb{R}}) - i_-(\rho_{\mathbb{R}})$$

which is called the *signature* of ρ (some authors call it the *index* of ρ). As $i_+ + i_- = n$, then $\sigma \equiv n \pmod{2}$ and

$$(i_+, i_-) = \left(\frac{n + \sigma}{2}, \frac{n - \sigma}{2} \right).$$

The signature is *additive with respect to orthogonal direct sum*:

$$\sigma(\rho \perp \rho') = \sigma(\rho) + \sigma(\rho').$$

We can distribute the unimodular \mathbb{Z} -forms into the following classes which are clearly invariant up to isometry.

(Definite/indefinite) (V, ρ) is *definite* either *positive* or *negative* if either for every $v \in V$, $v \neq 0$, $\rho(v, v) > 0$ or $\rho(v, v) < 0$. Otherwise, ρ is *indefinite*.

(Parity) (V, ρ) is *even* if for every $v \in V$, $\rho(v, v) \in 2\mathbb{Z}$ is even. If ρ is not even, then it is said *odd*. (V, ρ) is even if and only if there is a basis $\mathcal{B} = \{v_1, \dots, v_n\}$ of V such that for every $j = 1, \dots, n$, $\rho(v_j, v_j) \in 2\mathbb{Z}$; in such a case this happens for every basis of V .

So we have the combination sub-classes “definite/indefinite and even”, “definite/indefinite and odd”; the study up to isometry can be made sub-class by sub-class.

20.1.2. Some basic forms. \mathbf{U}_+ , \mathbf{U}_- are, up to isometry, the unique rank-1 forms. They are both definite (of opposite sign) and odd, $\sigma(\mathbf{U}_{\pm}) = \pm 1$.

We denote by \mathbf{H} the (isometry class of the) form defined on \mathbb{Z}^2 by

$$(x, y) \rightarrow x^t H y$$

where

$$H := \begin{pmatrix} 0 & 1 \\ 1 & 0 \end{pmatrix}$$

The form \mathbf{H} is indefinite and even; $\sigma(\mathbf{H}) = 0$.

Let us denote by \mathbf{E}_8 the (isometry class of the) form defined on \mathbb{Z}^8 by

$$(x, y) \rightarrow x^t E y$$

where $E = (e_{i,j})$ is the symmetric matrix 8×8 such that:

- For every i , $e_{i,i} = 2$;
- For $i = 1, \dots, 6$, $e_{i,i+1} = 1$;
- $e_{5,8} = 1$;
- $e_{i,j} = 0$ otherwise.

One verifies by direct computation that \mathbf{E}_8 is unimodular, even, positive definite; hence $\sigma(\mathbf{E}_8) = 8$. $-\mathbf{E}_8$ (that is the isometry class of $(\mathbb{Z}^8, -E)$) is even, negative definite with $\sigma(-\mathbf{E}_8) = -8$. Being even $\pm\mathbf{E}_8$ is *not diagonalizable*, that is it is not isometric to $8\mathbf{U}_\pm$.

20.1.3. Full classification up to rank 4. We have

PROPOSITION 20.1. *Isometry classes of symmetric unimodular \mathbb{Z} -bilinear forms of rank n up to 4 either are diagonalizable (i.e. they admit a orthonormal basis) or are even with null signature. The normal representatives are respectively:*

(1) **(Diagonalizable)** *The normal representative is*

$$|\sigma|\mathbf{U}_\epsilon \perp \frac{n - |\sigma|}{2}(\mathbf{U}_+ \perp \mathbf{U}_-)$$

where ϵ is the sign of the signature σ .

(2) **(Even)** *The normal representatives are either \mathbf{H} or $2\mathbf{H}$.*

□

The key geometric fact to get this result is that for every (V, ρ) such that $\text{rank}(V) \leq 4$, there is $v \neq 0$ in V such that $|\rho(v, v)| < 2$; this is an application of a theorem of Minkowski on the volume of lattice in euclidean spaces.

20.1.4. Classification of indefinite forms. This is summarized in the following theorem.

THEOREM 20.2. (1) *The triple*

$$(\text{rank, signature, parity})$$

is a complete invariant for the indefinite forms considered up to isometry.

(2) *For every indefinite isometry class we have the following distinguished representative, depending on the parity:*

(Indefinite and odd normal representatives) *For every rank n and signature σ this is*

$$|\sigma|\mathbf{U}_\epsilon \perp \frac{n - |\sigma|}{2}(\mathbf{U}_+ \perp \mathbf{U}_-)$$

where ϵ is the sign of σ . Hence indefinite odd forms are diagonalizable, that is they admit orthonormal basis.

(Indefinite and even normal representatives) *For every rank n and signature σ , $\sigma \equiv 0 \pmod{8}$, $n - |\sigma|$ is even and non zero and the normal representative is*

$$\frac{\sigma}{8}\mathbf{E}_8 \perp \frac{n - |\sigma|}{2}\mathbf{H}$$

where we mean $a\mathbf{E}_8 = -a(-\mathbf{E}_8)$ if $a < 0$.

□

The key fact for the indefinite classification is the number-theoretic *Meyer theorem* which states that for every indefinite (V, ρ) , there is $v \neq 0$ in V such that $\rho(v, v) = 0$. If $n \leq 4$ this follows from the above full classification. If $n \geq 5$, via the extension of coefficients $\mathbb{Z} \subset \mathbb{Q}$, one is reduced to prove that, alike for \mathbb{R} -spaces, a scalar product on a \mathbb{Q} -vector space of dimension $n \geq 5$ is definite if and only if for every non zero vector v , $\rho(v, v) \neq 0$. Note that the last statement fails for $n = 4$. The proof is based on *Hasse-Minkowski Theorem*. Then the indefinite odd case follows by a rather easy inductive argument. An important relation to achieve the odd case is:

$$\mathbf{H} \perp \mathbf{U}_{\pm} = \mathbf{U}_{\mp} \perp 2\mathbf{U}_{\pm} .$$

The classification in the indefinite and even case is more delicate, employs the already achieved odd classification and involves in the very statement certain congruence mod (8). We limit to clarify this last point.

20.1.5. Characteristic elements and congruences mod (8). Let (V, ρ) be as above. An element $u \in V$ is by definition *characteristic* if for every $v \in V$, $\rho(v, v) \equiv \rho(u, v) \pmod{2}$. We have the following so called *van der Blij lemma*.

- LEMMA 20.3. (1) For every (V, ρ) there are characteristic elements.
 (2) For every characteristic element u , $\sigma \equiv \rho(u, u) \pmod{8}$.
 (3) If ρ is even then $\sigma \equiv 0 \pmod{8}$.

Proof: (1): fix a basis of V , so that $V \sim \mathbb{Z}^n$ and let the $n \times n$ symmetric matrix A represent the form ρ . By reducing mod (2), we have the $\mathbb{Z}/2\mathbb{Z}$ -linear function $(\mathbb{Z}/2\mathbb{Z})^n \rightarrow \mathbb{Z}/2\mathbb{Z}$, $y \rightarrow y^t A y$. As $\det A = 1 \pmod{2}$, there is a unique representing vector $\bar{u} \in (\mathbb{Z}/2\mathbb{Z})^n$ such that for every y , $y^t A y = \bar{u}^t A y$. Every $u \in \mathbb{Z}^n$ whose reduction mod (2) is equal to \bar{u} is a characteristic element of ρ .

As for (2), if u and u' are characteristic elements, so that $u' = u + 2x$ for some $x \in V$, then $\rho(u', u') = \rho(u, u) + 4(\rho(u, x) + \rho(x, x)) \equiv \rho(u, u) \pmod{8}$. So $\rho(u, u)$ is invariant mod (8). It is additive with respect to the orthogonal direct sum and it holds ± 1 on \mathbf{U}_{\pm} . Then item (2) holds for indefinite and odd forms thanks to the classification in this case. On the other hand, $\rho \perp \mathbf{U}_+ \perp \mathbf{U}_-$ has the same signature of ρ and is indefinite and odd; so (2) holds in general.

Item (3) is an immediate corollary of (2).

□

20.1.6. Indefinite stabilizations. Given any form ρ there are simple ways to transform it into an indefinite one. The first is called *elementary odd stabilizations*:

$$\rho \rightarrow \rho \perp \mathbf{U}_{\epsilon}$$

for a suitable $\epsilon = \pm$, the resulting form is indefinite and odd. The signature changes by $\sigma \rightarrow \sigma \pm 1$.

$$\rho \perp (\mathbf{U}_+ \perp \mathbf{U}_-)$$

is always indefinite odd and the signature does not change.

The *elementary even stabilization* is

$$\rho \rightarrow \rho \perp \mathbf{H}$$

the resulting form is indefinite and is even if and only if ρ is even. The signature does not change.

Then the classification of indefinite odd forms induces a classification of *all* forms up to such odd stabilizations. Similarly, the classification of indefinite even forms induces a classification of all *even* forms up to even stabilization. In particular we have:

For every pair of forms ρ and ρ' there are $m_1, m_2, m'_1, m'_2, m \in \mathbb{N}$ such that

$$\rho \perp m_1 \mathbf{U}_+ \perp m_2 \mathbf{U}_- = \rho' \perp m'_1 \mathbf{U}_+ \perp m'_2 \mathbf{U}_- = m(\mathbf{U}_+ + \mathbf{U}_-).$$

20.1.7. Neutral forms and the Witt group. Similarly to Section 15.4.1, denote by $I(\mathbb{Z})$ the set of isometry classes of unimodular symmetric \mathbb{Z} -bilinear forms defined on free \mathbb{Z} -modules of arbitrary finite rank. The operation \perp makes it a semigroup. $S \in I(\mathbb{Z})$ is said *neutral* if $\text{rank } S = 2m$ is even and there is a submodule $Z \subset S$, $\text{rank } Z = m$ such that $Z = Z^\perp$. The following lemma is an immediate consequence of Theorem 20.2.

LEMMA 20.4. *An indefinite odd class is neutral if and only if it is of the form $m(\mathbf{U}_+ \perp \mathbf{U}_-)$ for some $m \geq 1$. An indefinite even class is neutral if and only if it is of the form $m\mathbf{H}$ for some $m \geq 1$.*

□

Put on $I(\mathbb{Z})$ the equivalence relation $X \sim X'$ if and only if there are neutral spaces S, S' such that

$$X \perp S = X' \perp S'.$$

Denote by $W(\mathbb{Z})$ the quotient set. The operation descends to $W(\mathbb{Z})$ and makes it an abelian group called the *Witt group* of the ring \mathbb{Z} . All this can be restricted to the set $I_0(\mathbb{Z})$ of even classes and gives rise to the restricted Witt group $W_0(\mathbb{Z})$. Also the following proposition is an easy consequence of Theorem 20.2.

PROPOSITION 20.5. *Both following maps are well defined group isomorphisms:*

$$\sigma : W(\mathbb{Z}) \rightarrow (\mathbb{Z}, +), \quad \frac{\sigma}{8} : W_0(\mathbb{Z}) \rightarrow (\mathbb{Z}, +).$$

Moreover, $W(\mathbb{Z})$ is generated by \mathbf{U}_+ while $W_0(\mathbb{Z})$ is generated by \mathbf{E}_8 .

□

20.2. Some 4-manifold counterparts

In analogy with the surface case, one would like to determine 4-manifold counterparts of the above abstract theory, at least for indefinite forms where the arithmetic classification is complete. In particular one would wonder that every indefinite normal representative is realized as the intersection form \bullet_M of some 4-dimensional smooth manifold M as above. Unfortunately this is too optimistic.

Notation: We set $\sigma_{\bullet_M} = \sigma(M)$.

First we establish a topological counterpart of the operation \perp . This is analogous to surface Lemma 15.7.

LEMMA 20.6. *Let (M_1, \bullet_{M_1}) and (M_2, \bullet_{M_2}) be 4-manifolds equipped with the respective intersection forms and set $M = M_1 \# M_2$. Then, up to isometry,*

$$\bullet_M = \bullet_{M_1} \perp \bullet_{M_2}.$$

Proof: Let $\alpha = [F] \in \mathcal{H}_2(M; \mathbb{Z})$ where F is a proper oriented surface embedded into M . Up to isotopy we can assume that $F \pitchfork S$, where S is a smooth 3-sphere in M which realizes the connected sum splitting of M . $L = F \cap S$ is a link in $S \sim S^3$. Then M is obtained by gluing $M'_j = M_j \setminus \text{Int}D^4$, $j = 1, 2$, along the two boundary components of a tubular neighbourhood $N(S) \sim S^3 \times [-1, 1]$ of S in M . $F_j = F \cap M'_j$ is a proper submanifold of M'_j with boundary L . F_j can be capped by means of a Seifert surface of L in S^3 . So we get boundaryless surfaces \hat{F}_j in M_j which up to isotopy can be embedded into M'_j . Hence, via the isomorphism induced

by the inclusions and a slight abuse of notation, we have $[F] = [\hat{F}_1] + [\hat{F}_2]$. Doing in a similar way for another class $\alpha' = [F']$, we get $\alpha \bullet \alpha' = [\hat{F}_1] \bullet [\hat{F}'_1] + [\hat{F}_2] \bullet [\hat{F}'_2]$. \square

REMARK 20.7. We stress that we are **not** claiming that every direct sum decomposition of an intersection form \bullet_M corresponds to a connected sum decomposition of the manifold M (see Example 20.11).

It is easy to realize \mathbf{U}_\pm and \mathbf{H} . In fact:

\mathbf{U}_\pm is the intersection form of $\pm \mathbf{P}^2(\mathbb{C})$, where $\mathbf{P}^2(\mathbb{C})$ is endowed with the natural orientation as a complex manifold. $\mathcal{H}_2(\mathbf{P}^2(\mathbb{C}); \mathbb{Z})$ is generated by $[\mathbf{P}^1(\mathbb{C})]$ that is represented by any complex line embedded into $\mathbf{P}^2(\mathbb{C})$. Hence *every indefinite and odd normal representative can be realized*.

Notation: To simplify the notation, set $\mathcal{P} = \mathbf{P}^2(\mathbb{C})$ and $\mathcal{Q} = -\mathbf{P}^2(\mathbb{C})$.

\mathbf{H} is the intersection form of $S^2 \times S^2$, where S^2 has the usual orientation and we take the product orientation. $\mathcal{H}_2(S^2 \times S^2; \mathbb{Z})$ has as basis $[S^2 \times \{p}]$ and $[\{p\} \times S^2]$ for any $p \in S^2$.

REMARK 20.8. Both $\mathbf{P}^2(\mathbb{C})$ and $S^2 \times S^2$ are simply connected. By Van Kampen theorem, the connected sum of two simply connected manifolds is also simply connected. So it makes sense (and we will do it at some point) to restrict the discussion to simply connected manifolds.

\mathbf{H} and $\mathbf{U}_+ \perp \mathbf{U}_-$ are the basic neutral classes. As for their 4-dimensional realizations we have

PROPOSITION 20.9. *Up to isomorphism of fibre bundles, there are two distinct fibre bundles over S^2 with fibre S^2 and orientable total space; $S^2 \times S^2$ and $\mathcal{P} \# \mathcal{Q} := S^2 \tilde{\times} S^2$ are the respective total spaces.*

Proof: By at theorem of Smale [S1] (recall also Section 7.5.2) $\text{Diff}^+(S^2)$ retracts by deformation to $SO(3) \sim \mathbf{P}^3(\mathbb{R})$. Then there are exactly two such fibre bundles because $\pi_1(SO(3)) \sim \mathbb{Z}/2\mathbb{Z}$ (recall Section 5.7). $\mathcal{P} \# \mathcal{Q}$ can be obtained by the complex blow up of $\mathbf{P}^2(\mathbb{C})$ at a point. It follows from the proof of Proposition 7.29 that it is the total space of a fibre bundle as in the statement of the proposition. More precisely, let \mathcal{D} be the unitary disk in an affine chart of \mathcal{P} at a point $x_0 \sim 0$. Then $\mathbf{B}_{\mathbb{C}}(\mathcal{D}, 0)$ is the oriented total space of a fibre bundle over the Riemann sphere $S^2 \sim \mathbf{P}^1(\mathbb{C})$ with fibre D^2 ; the fibres are given by the strict transform of the intersection with \mathcal{D} of the complex lines through 0. Set $\mathcal{P}_0 := \mathcal{P} \setminus \text{Int}\mathcal{D}$. Also \mathcal{P}_0 is the total space of a fibre bundle of the same type. Considering $\mathbf{P}^1(\mathbb{C}) \subset \mathcal{P}_0$, the fibres are given by the intersection with \mathcal{P}_0 of the complex lines passing through 0 and $x \in \mathbf{P}^1(\mathbb{C})$. The restriction of these fibres to $\partial\mathcal{D}$ induce the Hopf fibration $\mathfrak{h} : S^3 \rightarrow S^2$. Then $\mathbf{B}_{\mathbb{C}}(\mathcal{P}, x_0)$ is diffeomorphic to the double $D(\mathcal{P}_0) = \mathcal{P}_0 \amalg -\mathcal{P}_0 / \text{id}_{S^3}$ and hence to $\mathcal{P} \# \mathcal{Q}$. The fibration of $\mathcal{P} \# \mathcal{Q}$ with fibre S^2 is obtained by gluing “along the Hopf fibration” the two fibrations with fibre D^2 described so far. Finally $S^2 \times S^2$ and $\mathcal{P} \# \mathcal{Q}$ are distinguished by the intersection forms. \square

Now we discuss a topological counterpart of the relation

$$\mathbf{H} \perp \mathbf{U}_\pm = \mathbf{U}_\mp \perp 2\mathbf{U}_\pm$$

this is analogous to surface Lemma 15.12.

PROPOSITION 20.10. *We have*

$$(S^2 \times S^2) \# \mathcal{Q} \sim \mathcal{P} \# 2\mathcal{Q}, \quad (S^2 \times S^2) \# \mathcal{P} \sim \mathcal{Q} \# 2\mathcal{P} .$$

Proof : As $S^2 \times S^2$ admits an orientation reversing diffeomorphism, the two relations are equivalent to each other. The second geometric proof of Lemma 15.12 applies *verbatim* to prove the first relation, provided that one replaces \mathbb{R} with \mathbb{C} everywhere. □

A realization of indefinite even normal representatives, or of \mathbf{E}_8 itself, possibly by means of a simply connected smooth 4-manifold M , is much more subtle and hard question. We will discuss later the following fundamental Rohlin’s discovery:

If M is simply connected and its intersection form is even, then $\sigma(M) \equiv 0 \pmod{16}$.

Recall that algebra tells us that the signature of an even form is $\equiv 0 \pmod{8}$. Then \mathbf{E}_8 cannot be realized. If M is simply connected with indefinite and even intersection form, then this is necessarily isometric to a normal representative of the type

$$2a\mathbf{E}_8 \perp b\mathbf{H}$$

for some $a \in \mathbb{Z}$, $b \in \mathbb{N} \setminus \{0\}$. It is not evident (and ultimately false) that every such pair (a, b) can be realized. On the other hand, classical simply connected examples show the actual occurrence of \mathbf{E}_8 .

EXAMPLE 20.11. If we relax the requirement of dealing with normal representatives, it is not hard to make \mathbf{E}_8 visible. For example, by the indefinite and odd classification, the form of $M = 10\mathcal{P} \# \mathcal{Q}$ is isometric to

$$\mathbf{E}_8 \perp \mathbf{U}_+ \perp \mathbf{H} .$$

Nevertheless, this algebraic decomposition does not correspond to any connected sum decomposition of M .

A more substantial example, realizing a normal representative, is the so called *Kummer variety*. Let the 4-torus $T^4 = \mathbb{R}^4/\mathbb{Z}^4$ be realized as the product of two copies of $\mathbb{C}/(\mathbb{Z} \oplus i\mathbb{Z})$ so that T^4 has a complex 2-manifold structure with “uniformizing” complex coordinates (w_1, w_2) . The involution $\tau(w_1, w_2) = (-w_1, -w_2)$ descends to T^4 and has 16 fixed points. Let us perform the complex blow-up at such fixed points. We get a complex surface \tilde{K} , smoothly diffeomorphic to $T^4 \# 16\mathcal{Q}$. The exceptional complex surface over each fixed point is a Riemann sphere S with self-intersection number in \tilde{K} equal to -1 . The involution τ lifts to an involution $\tilde{\tau}$ of \tilde{K} which is the identity on each exceptional sphere. We consider the quotient

$$K := \tilde{K}/\tilde{\tau} .$$

One verifies that K is a smooth complex surface. By means of the natural projection, every exceptional sphere S maps onto a 2-sphere S' embedded into K ; the restriction of the projection on a suitable neighbourhood of each S in \tilde{K} is a double covering of a neighbourhood in K of the corresponding sphere S' . Then the self-intersection number of every S' in K is equal to -2 . One can verify that $\mathcal{H}_2(T^4; \mathbb{Z}) \sim \mathbb{Z}^6$ and is generated by six embedded 2-tori, while $\mathcal{H}_2(K; \mathbb{Z}) \sim \mathbb{Z}^{22}$ generated by the image of these tori together with the 16 spheres S' . Eventually the intersection form of K is indefinite and even with normal representative $-2\mathbf{E}_8 \perp 3\mathbf{H}$.

20.2.1. On the intersection form of 4-manifolds with boundary. If $\partial M \neq \emptyset$, the intersection form $\sqcup : \mathcal{H}^2(M; \mathbb{Z}) \times \mathcal{H}^2(M; \mathbb{Z}) \rightarrow \mathbb{Z}$ and the \mathbb{Z} -linear map

$$\hat{\phi}^2 : \mathcal{H}^2(M; \mathbb{Z}) \rightarrow \text{Hom}(\mathcal{H}_2(M; \mathbb{Z}), \mathbb{Z})$$

are defined as well. In general the form is not unimodular. If $\beta := i_*(\alpha) \neq 0$ in $\mathcal{H}_2(M; \mathbb{Z})$ for some $\alpha \in \mathcal{H}_2(\partial M; \mathbb{Z})$, then $\beta \sqcup \gamma = 0$ for every γ . On the other hand, it follows from the results of Chapter 13 that

$$\hat{\phi}^2 : \mathcal{H}^2(M, \partial M; \mathbb{Z}) \rightarrow \text{Hom}(\mathcal{H}_2(M; \mathbb{Z}), \mathbb{Z})$$

is an isomorphism. Hence the intersection form of M is unimodular if and only if $j_* : \mathcal{H}_2(M; \mathbb{Z}) \rightarrow \mathcal{H}_2(M, \partial M; \mathbb{Z})$ is an isomorphism. For simplicity assume that M is part of a triad of the form $(M, \emptyset, V = \partial M)$ admitting an ordered handle decomposition with one 0-handle, some 2-handles, say k , no 3 and 4-handles. In other words, by removing the 0-handle, we realize a surgery equivalence $S^3 \sim_\sigma V$. Hence V is connected and M is simply connected. We claim that every symmetric \mathbb{Z} -bilinear form (not necessarily unimodular) can be realized by such a 4-manifold. Let us sketch the argument. By using Section 9.3.1 we see that M retracts to a wedge of k 2-spheres. By using the bordism homotopy invariance and what we know about the bordism of S^2 , we see that $\mathcal{H}_2(S^2; \mathbb{Z})$ has rank k ; a geometric basis $\alpha_1, \dots, \alpha_k$ can be obtained by completing the core of every 2-handle with a Seifert surface of the corresponding attaching knot in S^3 (provided the handles have been ordered). The k -components framed link in S^3 which encodes the attaching of 2-handles carries a symmetric *linking matrix* made by the linking numbers of pairs of constituent knots and, along the diagonal, by the integers encoding the framing of every such a knot. With a bit of work one eventually realizes that this matrix equals the matrix of the intersection form of M with respect to the above geometric basis. In Figure 1 we show a framed link in S^3 which realizes \mathbf{E}_8 ; ∂M is the *Poincaré sphere*.

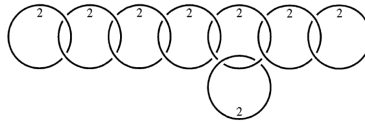

FIGURE 1. A \mathbf{E}_8 -link.

We have

PROPOSITION 20.12. *The intersection form of M is unimodular if and only if $\mathcal{H}_1(V; \mathbb{Z}) = \mathcal{H}_2(V; \mathbb{Z}) = 0$.*

Proof : As M is simply connected, $\mathcal{H}_3(M, \partial M; \mathbb{Z}) \sim \text{Hom}(\mathcal{H}_1(M; \mathbb{Z}), \mathbb{Z}) = 0$. Hence by using the bordism long exact sequence of $(M, \partial M)$, we see that $i_* : \mathcal{H}_2(V; \mathbb{Z}) \rightarrow \mathcal{H}_2(M; \mathbb{Z})$ is injective; hence if the intersection form of M is unimodular, then $\mathcal{H}_2(V; \mathbb{Z}) = 0$. On the other hand, if $\mathcal{H}_1(V; \mathbb{Z}) = 0$, consider the dual handle decomposition; the cores of the 2-handles provide a basis of $\mathcal{H}_2(M, \partial M; \mathbb{Z})$; by capping each of them with a Seifert surface in V of the corresponding attaching knot, we get a further geometric basis of $\mathcal{H}_2(M; \mathbb{Z})$ dual to the previous one. □

If the intersection form of M is unimodular, possibly by performing an elementary blow-up move (which replaces M with $M \# \pm \mathbf{P}^2(\mathbb{C})$, without modifying the boundary V), we can assume that the unimodular intersection form of M is diagonalizable. If one 2-handle (corresponding to a constituent knot K_i) is slid over another, say corresponding to K_j , then the geometric basis as above, changes by sending α_i to $\alpha_i + \alpha_j$, and the linking matrix changes by adding the j^{th} row to the i^{th} row, and the j^{th} column to the i^{th} . It follows that we can realize a diagonalizing basis by means of handle sliding.

The same discussion can be repeated (with some simplification) by replacing everywhere \mathbb{Z} with $\mathbb{Z}/2\mathbb{Z}$.

20.3. Ω_4

We already know that Ω_4 is non trivial because $\chi_{(2)}(\mathbf{P}^2(\mathbb{C})) = 1$. More precisely we have a surjective homomorphism defined by

$$\chi_{(2)} : \Omega_4 \rightarrow \mathbb{Z}/2\mathbb{Z}, \quad \chi_{(2)}([M]) := \chi_{(2)}(M) .$$

Pontryagin remarked that there is a subtler homomorphism induced by the signature. As usual

$$[M \# M'] = [M \amalg M'] = [M] + [M'] \in \Omega_4$$

so that every $\alpha \in \Omega_4$ can be represented by connected 4-manifolds and we can replace \amalg with $\#$ to define the \mathbb{Z} -module operation on Ω_4 . Then we have

PROPOSITION 20.13.

$$\sigma : \Omega_4 \rightarrow \mathbb{Z}, \quad \sigma(\alpha) := \sigma(M)$$

where M is any connected representative of the class α , is a well defined and surjective homomorphism.

Proof : As the signature is additive with respect to the connected sum, $\sigma(M) = -\sigma(-M)$ and $\sigma(\mathbf{P}^2(\mathbb{C})) = 1$, it is enough to show that if $[M] = 0 \in \Omega_4$, then $\sigma(M) = 0$. To compute the signature, that is the indices i_+, i_- , it is enough to extend the coefficients $\mathbb{Z} \subset \mathbb{Q}$. For every $\alpha \in \mathcal{H}_2(M; \mathbb{Q})$ there exists $m \in \mathbb{Z}$ such that $m\alpha = \alpha' \in \mathcal{H}_2(M; \mathbb{Z})$, and $\alpha \bullet \alpha = \alpha' \bullet \alpha' / (m^2)$. If for every $\alpha \in \mathcal{H}_2(M; \mathbb{Q})$, $\alpha \bullet \alpha = 0$, then $\sigma = 0$. Let $M = \partial W$, $i : M \rightarrow W$ be the inclusion. If $i_*(\alpha) = 0$, then $\alpha' \bullet \alpha' = 0$, hence $\alpha \bullet \alpha = 0$. So if for every α , $i_*(\alpha) = 0$, then $\sigma = 0$. Assume that $i_*(\alpha) \neq 0$. Then there is $b \in \mathcal{H}_3(W, M; \mathbb{Q})$ such that $\beta := \partial b \in \mathcal{H}_2(M; \mathbb{Q})$ and $\alpha \bullet \beta = 1$, $i_*(\beta) = 0$. Let V be the subspace of $\mathcal{H}_2(M; \mathbb{Q})$ generated by α and β . The matrix of the restriction of the intersection form on V has $\det = -1$, hence its signature is equal to zero. As the restriction of the form to V is non degenerate, also its restriction on the orthogonal space V^\perp is non degenerate. Then we can iterate the construction till one finds classes such that $i_*(\alpha) \neq 0$. By the additivity of the signature with respect to the orthogonal direct sum, we conclude that $\sigma = 0$. \square

We are ready to state and prove the following theorem due to Rohlin (see [GM]). We will propose his original argument. This is formally analogous to surface Theorems 15.14 and 15.15.

THEOREM 20.14. *The homomorphism induced by the signature $\sigma : \Omega_4 \rightarrow \mathbb{Z}$ is an isomorphism. Hence Ω_4 is generated by $[\mathbf{P}^2(\mathbb{C})]$ and is naturally isomorphic to the Witt group $W(\mathbb{Z})$.*

Proof : The restriction of σ to the submodule of Ω_4 generated by $[\mathbf{P}^2(\mathbb{C})]$ is an isomorphism onto \mathbb{Z} . Hence it is enough to show that Ω_4 is generated by $[\mathbf{P}^2(\mathbb{C})]$. We will achieve this fact by several steps. Let M be as usual a compact, oriented, connected and boundaryless 4-manifold.

Step 1. This is similar to the first step in Rohlin's proof that $\Omega_3 = 0$. That is, up to bordism, it is not restrictive to assume that $M \subset \mathbb{R}^7 \subset S^7$. (see also [Kirby] for a somewhat different conclusion of the proof based on Step 1).

Step 2. We would like to construct along M a field v of unitary tangent vector to S^7 normal to M . This is not possible in general, however we are going to see that there is $\tilde{M} := M \# a\mathcal{P} \# b\mathcal{Q} \subset S^7$ for some $a, b \in \mathbb{N}$, which carries such a nowhere vanishing transverse field. A first obstruction is given by the Euler class $e \in \mathcal{H}^3(M; \mathbb{Z})$ of a normal bundle to M in S^7 . On the other hand, $[M] = 0 \in \mathcal{H}^3(S^7; \mathbb{Z})$ and $e = i^*([M]) = 0$. This implies that such a field v can be defined on $M_0 = M \setminus \text{Int}B^4$, where B^4 is a smooth 4-disk in M ; in fact M_0 has a 3-dimensional spine, v can be always constructed up to the 2-skeleton and the obstruction to

extend it to the third skeleton belongs to $\pi_2(S^2)$ and vanishes because $e = 0$. The restriction of v to ∂M_0 defines an element of $\pi_3(S^2)$ which is in general non trivial. This is the final effective obstruction to extend v on the whole of M . We know that $\pi_3(S^2) = \mathbb{Z}$ is generated by the Hopf map $\mathfrak{h} : S^3 \rightarrow S^2$. By transversality we can perturb the field v and assume that it is defined on M' obtained by removing from M the interior of a finite number of disjoint 4-disks B_j embedded into $\text{Int}B$ such that the restriction of v to every boundary ∂B_j is equal to $\pm \mathfrak{h}$. By using the field v we get an embedding of M' into the boundary $\partial N(M)$ of a tubular neighbourhood of M in S^7 . By abstractly gluing to every boundary component of M' the mapping cylinder of the corresponding map $\pm \mathfrak{h}$, we get the 4-manifold $\tilde{M} := M \#_a \mathcal{P} \#_b \mathcal{Q}$ for some $a, b \in \mathbb{N}$. We claim that we can assume that $\tilde{M} \subset \partial N(M)$ by extending the given embedding of M' . For if $B_j \times D^3$ is a trivialized chart of $N(M)$ over the 4-ball B_j , the embedding of ∂B_j is for instance of the form $x \rightarrow (x, \mathfrak{h}(x))$ and \mathcal{P}_0 is the copy of $\mathcal{P} \setminus \text{Int}(D^4)$ in \tilde{M} corresponding to B_j , then an embedding of \mathcal{P}_0 is given (by using suitable homogeneous coordinates (x_0, x_1, x_2)) by:

$$(x_0, x_1, x_2) \rightarrow \left(\left(\frac{2x_0x_1}{\sum_{i=0}^2 |x_i|^2}, \frac{2x_0, x_2}{\sum_{i=0}^2 |x_i|^2} \right), \frac{x_1}{x_2} \right) \in B_j \times \mathbf{P}^1(\mathbb{C}) .$$

Clearly, the restriction \tilde{v} to \tilde{M} of a unitary normal field to the hypersurface $\partial N(M)$ in S^7 is nowhere vanishing along \tilde{M} .

Step 3. The field \tilde{v} determines an embedding of a copy \hat{M} of \tilde{M} into $\partial N(\tilde{M})$ the boundary of a tubular neighbourhood $\pi : N(\tilde{M}) \rightarrow \tilde{M}$ of \tilde{M} in S^7 . Set $X := S^7 \setminus \text{Int}N(\tilde{M})$. If $[\hat{M}]$ would be zero in $\mathcal{H}_4(X; \mathbb{Z})$, then it should be a boundary thanks to Proposition 13.9, and finally M bordant with $k\mathbf{P}^2(\mathbb{C})$ for some $k \in \mathbb{Z}$. However, we cannot assume that $[\hat{M}] = 0$.

Claim 1. *There is an oriented surface F in \tilde{M} such that the disjoint union of inclusions $j : \hat{M} \amalg \partial\pi^{-1}(F) \rightarrow \partial N(\tilde{M})$ represents zero in $\mathcal{H}_4(X; \mathbb{Z})$ (the 4-manifold $S := \partial\pi^{-1}(F)$ is oriented by the direct sum of the orientation of F and the orientation of the normal bundle of \hat{M} in $\partial N(\tilde{M})$).*

Let us prove the claim. $\mathcal{H}_4(S^7; \mathbb{Z}) = 0$, more precisely $\Omega_4(S^7) \sim \Omega_4$. Hence there is an oriented triad (W, \hat{M}, V) and a map $h : W \rightarrow S^7$ where the restriction to \hat{M} is the inclusion and the restriction to V is a constant map. By transversality we can assume that the restriction of h to an open collar of \hat{M} in W is an embedding in X transverse to $\partial N(\tilde{M})$, the image of V is in the interior of X , the restriction of h to the interior of W is transverse to $(N(\tilde{M}), \partial N(\tilde{M}))$ and \hat{M} . Then $F = h(\text{Int}(W)) \cap \tilde{M}$ is a surface in \tilde{M} and $h(\text{Int}(W)) \cap \partial N(\tilde{M}) = \partial\pi^{-1}(F) := S$. Finally $(h^{-1}(X), h)$ realizes a bordism between $(\hat{M} \amalg \partial S, j)$ and $(V, h|_V)$. The claim is proved.

With a slight abuse of notation we write $[\hat{M} \amalg S]$ instead of $[\hat{M} \amalg S, j]$.

Step 4. Let F be as in Claim 1. Clearly $S := \pi^{-1}(F)$ is the boundary of a 2-disk bundle. Then it would be enough to prove that $[\hat{M} \amalg S] = 0$. We are able to do it under a more restrictive hypothesis. We can assume that \hat{M} is transverse to S in $\partial N(\tilde{M})$ and that $\hat{M} \cap S = F_1$ where F_1 is the copy of F in $\partial N(\tilde{M})$ determined by the above normal unitary field \tilde{v} along \tilde{M} .

Claim 2. *Assume that the oriented normal bundle to F_1 in \hat{M} is isomorphic to the oriented normal bundle of F_1 in S . Then $[\hat{M} \amalg S] = 0$.*

Let U_1 be a tubular neighbourhood of F_1 in \hat{M} , U_2 a tubular neighbourhood of F_1 in S . We can construct a manifold Y by gluing $\hat{M} \setminus \text{Int}(U_1)$ and $S \setminus \text{Int}(U_2)$ along the boundary which are isomorphic by hypothesis. In fact Y can be realized within $\partial N(\tilde{M})$ in such a way that it contains isotopic copies of the original constituent pieces. It is not hard to check that Y is bordant with $\hat{M} \amalg S$ and that $[Y] =$

$[\hat{M}] + [S] = 0$ in $\mathcal{H}_4(X; \mathbb{Z})$. By Proposition 13.9 Y is a boundary and hence also $M \amalg S$ is so.

Step 5. In general the normal bundles of F_1 in \hat{M} and S respectively are not isomorphic to each other. The oriented rank-2 normal bundle of F_1 in \hat{M} is determined up to isomorphism by the self-intersection number of F_1 in \hat{M} . One realizes that by performing a complex (anti) blow up of \hat{M} at a point of F_1 we get a manifold \hat{M}' diffeomorphic to $\hat{M} \# \pm \mathbf{P}^2(\mathbb{C})$ such that the strict transform of F_1 in \hat{M}' is equal to F_1 and its self intersection number varies by ± 1 . Moreover, it is not restrictive to assume that \hat{M}' is realized within $\partial N(\tilde{M})$. By iterating this construction we eventually get $\hat{M}' \sim \hat{M} \# p\mathcal{P} \# q\mathcal{Q} = M \# k\mathcal{P} \# h\mathcal{Q}$ to which Claim 2 applies. Theorem 20.14 is eventually achieved. □

20.4. Simply connected classification up to odd stabilization

In this section we restrict to *simply connected* 4-manifolds. We are going to prove:

THEOREM 20.15. *For every compact oriented simply connected boundaryless 4-manifold M , there exist $(k, h), (m, n) \in \mathbb{N} \times \mathbb{N}$ such that $M \# k\mathcal{P} \# h\mathcal{Q} = m\mathcal{P} \# n\mathcal{Q}$.*

By using Proposition 20.10 one can slightly refine the statement in the form:
 \dots there exists $(k, m) \in \mathbb{N} \times \mathbb{N}$ such that $M \# (k + 1)\mathcal{P} \# k\mathcal{Q} = (m + 1)\mathcal{P} \# m\mathcal{Q}$.

Theorem 20.15 is analogous to surface Section 15.5, however we have not here any *a priori* information about the integers k, h, m, n . By Theorem 20.14, for every M as above there is $l \in \mathbb{Z}$ such that $M \# l\mathbf{P}^2(\mathbb{C})$ and this last is still simply connected; then Theorem 20.15 will readily follow by combining the next proposition with Proposition 20.10.

PROPOSITION 20.16. *Let M be simply connected and a boundary. Then there are $(k_0, k_1), (h_0, h_1) \in \mathbb{N} \times \mathbb{N}$ such that*

$$M \# k_0(S^2 \times S^2) \# k_1(S^2 \tilde{\times} S^2) \sim h_0(S^2 \times S^2) \# h_1(S^2 \tilde{\times} S^2) .$$

Proof: As M is a boundary, there is an oriented triad (W, M, S^4) . Let us take an ordered handle decomposition of (W, M, S^4) without 0- and 5-handles. Hence it is of the form

$$(M \times [0, 1]) \cup \{\mathcal{H}^1\} \cup \{\mathcal{H}^2\} \cup \dots \cup \{\mathcal{H}^4\} \cup ([-1, 0] \times S^4)$$

where every \mathcal{H}_j , $j = 1, \dots, 4$, denotes a pattern of a_j j -handles attached simultaneously at disjoint attaching tubes. We claim that we can modify the 5-manifold W without changing the boundary $M \amalg S^4$ in such a way that it is not restrictive to assume that $a_1 = a_4 = 0$. To do it we apply the “trading” argument already used in the proof of Proposition 19.8. We can assume that the attaching tube a every 1-handle is contained in a smooth 4-disk of M . Then the new boundary component obtained by modifying M can be realized as well by means of a 3-handle trivially attached to M ; thus we can trade every 1-handle with a 3-handle. By using the dual handle decomposition we can trade every 4-handle with a 2-handle; so, up to reordering, we can assume that the ordered handle decomposition of (W, M, S^4) contains only 2 and 3 handles. Hence W can be obtained by gluing $(M \times [0, 1]) \cup \{\mathcal{H}_2\}$ and $\{\mathcal{H}_3\} \cup ([-1, 0] \times S^4)$ along diffeomorphic boundary components. Note that in terms of the dual decomposition, also $\{\mathcal{H}_3\} \cup ([-1, 0] \times S^4)$ is obtained by attaching 2-handles. Then the following lemma allows us to conclude.

LEMMA 20.17. *Consider the cylinder $(M \times [0, 1], M_0, M_1)$, $M_j = M \times \{j\}$. Let (Y, M_0, \hat{M}_1) obtained by attaching a 2-handle to $M \times [0, 1]$ along M_1 . Assume that M is simply connected. Then either $\hat{M}_1 \sim M \# (S^2 \times S^2)$ or $\hat{M}_1 \sim M \# (S^2 \tilde{\times} S^2)$.*

Proof : As $\dim M = 4$ and M is simply connected, the attaching 1-sphere of the handle is isotopic to a standard S^1 in a chart of M . Then it is easy to check that $M_1 \sim M \# \mathcal{F}$ where \mathcal{F} is the total space of an oriented fibre bundle over S^2 with fibre S^2 . Then we apply Proposition 20.9. The lemma and Proposition 20.16 are proved. □

20.5. On the classification up to even stabilization

As in the previous section we deal with simply connected 4-manifolds. Being very sketchy, we are going to discuss the following deeper result [Wall3], [Wall4].

THEOREM 20.18. *Let M_0 and M_1 be compact oriented simply connected boundaryless 4-manifolds with isometric intersection forms. Then there is $k \in \mathbb{N}$ such that $M_0 \# k(S^2 \times S^2) \sim M_1 \# k(S^2 \times S^2)$.*

A few comments are in order:

- In a sense this is the strongest 4-dimensional analogous of surface classification in terms of the intersection form, which one has obtained by means of classical differential/topological methods available till the ends of 70's of the last century.

- Theorem 20.18 implies Theorem 20.15. For up to a suitable odd stabilization $M \# \pm \mathbf{P}^2(\mathbb{C})$, this last has the same intersection form of some $k\mathcal{P} \# h\mathcal{Q}$. By applying to this couple of manifolds Theorem 20.18 and Proposition 20.10, we get Theorem 20.15. In fact a proof of Theorem 20.18 is much more demanding, it incorporates the one of Theorem 20.15, together with more advanced tools in homotopy and homology theory beyond the limits of the present text. So we will give just some indications. A detailed proof can be found for example in [Sc].

- For our main application in Section 20.6, the simpler classification up to odd stabilization will suffice.

First one proves the theorem under a stronger hypothesis. The idea is that the h -cobordism theorem holds also in dimension 5 up to even stabilization.

PROPOSITION 20.19. *Let M_0 and M_1 be compact oriented simply connected boundaryless 4-manifolds. Assume that they are h -cobordant. Then there is $k \in \mathbb{N}$ such that $M_0 \# k(S^2 \times S^2) \sim M_1 \# k(S^2 \times S^2)$.*

Sketch of proof: We know that the main difficulty to perform the stable proof of the h -cobordism theorem in dimension 5 is that we cannot apply the Whitney trick to eliminate couples of intersection points between the b -sphere S_b and the a -sphere S_a of two *algebraically* complementary handles. In particular, trying to construct a Whitney disk, we cannot avoid that such a generically immersed 2-disk D has self-intersection points. Let p such a point. Let us make the connected sum with a copy of $S^2 \times S^2$. This contains two 2-spheres S_1 and S_2 which intersect transversely at one point. By means of a thin embedded 1-handle we connect D with S_1 obtaining a new immersed 2-disk D' ($D' \sim D \# S_1$) which intersects transversely S_2 at one point q . Let c be a simple arc on D' which connects p and q and does not pass through other self-intersection points. By using another thin embedded 1-handle along c we connect D' with a parallel copy of S_2 and get D'' from which both the self-intersection points p and q have been eliminated. Hence up to a certain number of even stabilizations we can assume that D is embedded and eventually provides a genuine Whitney disk. □

The classification up to even stabilization is now a consequence of the “if” implication in the the following deep Wall’s theorem.

THEOREM 20.20. *Let M_0 and M_1 be compact oriented simply connected boundaryless 4-manifolds. Then they are h -cobordant if and only if they have isometric intersection forms.*

Being even more sketchy: “if” is the hard implication; it strenghtens a classical Whitehead theorem (based on CW complex techniques) according to which M_0 and M_1 have the same homotopy type. If the intersection forms are isometric then they have in particular the same signature, so that M_0 is bordant with M_1 by Theorem 20.14 . Arguing as in the proof of Proposition 20.16, we know that there are triads (W, M_0, M_1) where W is obtained by gluing some V with boundary $\partial V = M_0 \amalg (M_0 \# k(S^2 \times S^2) \# h(S^2 \tilde{\times} S^2))$ and some V' with boundary $\partial V' = (M_1 \# k'(S^2 \times S^2) \# h'(S^2 \tilde{\times} S^2)) \amalg M_1$, via a diffeomorphism

$$\phi : M_0 \# k(S^2 \times S^2) \# h(S^2 \tilde{\times} S^2) \rightarrow M_1 \# k'(S^2 \times S^2) \# h'(S^2 \tilde{\times} S^2) .$$

As M_0 and M_1 are simply connected, then also W is so. The key point is to show that, by fully exploiting the hypothesis, amongs the triads of this kind there are such that W is homologically trivial; by standard algebraic/topological arguments this is enough to conclude that the triad (W, M_0, M_1) is a h -cobordism.

20.6. Congruences modulo 16

To introduce the theme, let us begin with a bit of history. We have recalled in Section 17.4.3 that by means of the hardest application of Pontryagin method, in a series of four papers of 1951-52 (see [GM] for the translation in french and wide deep commentaries) Rohlin eventually computed the stable homotopy group

$$\pi_3^\infty = \pi_{n+3}(S^n) \sim \Omega_3^{\mathcal{F}}(S^n) \sim \mathbb{Z}/24\mathbb{Z}, \quad n \geq 5 .$$

As a corollary he obtained his celebrated congruence mod(16); a slightly weaker formulation of it is as follows:

THEOREM 20.21. *Let M be a compact oriented boundaryless simply connected 4-manifold. Assume that its intersection form is even. Then $\sigma(M) \equiv 0 \pmod{16}$.*

As $\sigma(M)$ is even, the arithmetic of unimodular forms tells us that $\sigma(M) \equiv 0 \pmod{8}$, so we can reformulate the result as

$$\frac{\sigma(M)}{8} \equiv 0 \pmod{2} .$$

This improvement by 2 implies in particular that \mathbf{E}_8 cannot be realized by any simply connected 4-manifold. The derivation of Theorem 20.21 from stably $\pi_{n+3}(S^n) \sim \mathbb{Z}/24\mathbb{Z}$ is rather demanding and uses several facts less elementary than the ones covered by the present text. Just to give an idea, without any pretention to be understandable, let us sketch the argument by following [MK]. It is shown that $p_1(M) = 3\sigma(M)$ where $p_1(M)$ denotes the first Pontryagin number of $T(M)$ (see Remark 16.9). This follows because both p_1 and σ are bordism invariant, additive on connected sum and the formula holds for the generator of $\Omega_4 = \mathbb{Z}$. So it is enough to prove that $p_1(M) \equiv 0 \pmod{48}$. One can assume that $M \subset \mathbb{R}^{4+n}$, $n \geq 5$. In the hypotheses of Rohlin’s theorem, one can prove that M is almost parallelizable that is the tangent bundle of $M \setminus \{x_0\}$ admit a global trivialization. Let f be a non vanishing section of the restriction to $M \setminus \{x_0\}$ of the $SO(n)$ normal bundle ν of M in \mathbb{R}^{4+n} . Let ϵ be the obstruction to extending f ; it is identified with an element of $\pi_3(SO(n))$ (which is an infinite cyclic group), as well as the Pontryagin number $p_1(\nu)$ is identified with $\pm 2\epsilon$. Consider the J -homomorphism (Section 17.4.1) $J : \pi_3(SO(n)) \rightarrow \pi_{3+n}(S^n)$. One proves that $J(\epsilon) = 0$, hence ϵ is divisible by 24. Finally one proves that $p_1(M) = -p_1(\nu)$ because $T(M) \oplus \nu = \epsilon^{4+n}$.

An interesting feature of this history is that in the second paper of the series, Rohlin outlined a proof of the *erroneous* result that stably $\pi_{n+3}(S^n) \sim \mathbb{Z}/12\mathbb{Z}$. Arguing as above this would imply the non surprising congruence $\sigma(M) \equiv 0 \pmod{8}$. In the fourth paper, after having established the isomorphism $\sigma : \Omega_4 \rightarrow \mathbb{Z}$ determined by the signature (i.e. Theorem 20.14), he firstly realized that this combined with some claims in his early presumed proof produced a contradiction, then he localized the mistake and corrected it getting the right group $\mathbb{Z}/24\mathbb{Z}$. In fact he pointed out that there was only one substantial mistake: a certain simply connected 4-manifold M has been constructed with a characteristic element $\omega \in \mathcal{H}^2(M; \mathbb{Z})$ of its intersection form which can be represented by a generic immersion $f : S^2 \rightarrow M$; then by an *abusive* application of the Whitney trick in dimension 4, he argued erroneously that ω was represented by an *embedded* $S^2 \subset M$. This was a quite fruitful mistake: his correction leads to the celebrated congruence mod(16) and provides a *concrete counterexample* to the applicability of Whitney's trick in dimension 4. Moreover, by elaborating on this counterexample the authors pointed out in [KM] (1961) an interesting extension. Recall that for every 4-manifolds M and for every characteristic element $\omega \in \mathcal{H}^2(M; \mathbb{Z})$ of its intersection form

$$\sigma(M) - \omega \sqcup \omega \equiv 0 \pmod{8} .$$

Then, assuming Theorem 20.21, the following theorem is proved in [KM].

THEOREM 20.22. *Let M be a compact oriented boundaryless simply connected 4-manifold. Let $\omega \in \mathcal{H}^2(M; \mathbb{Z})$ be a characteristic element of its intersection form that can be represented by an embedded 2-sphere. Then*

$$\frac{\sigma(M) - \omega \sqcup \omega}{8} \equiv 0 \pmod{2} .$$

If the intersection form is even, then we can take $\omega = 0$ and recover Rohlin's theorem. In general a characteristic element ω as above can be represented by an oriented surface F embedded in M but not necessarily by a 2-sphere. For example take $M = \mathcal{P} \# 8\mathcal{Q}$. If a_0 is the standard generator of $\mathcal{H}^2(\mathcal{P}; \mathbb{Z})$ represented by a projective complex line, and similarly a_j for the j th-copy of \mathcal{Q} , then $\omega := 3a_0 + a_1 + \dots + a_8$ is characteristic and $\omega \sqcup \omega - \sigma(M) = 8$, hence ω cannot be represented by a 2-sphere by Theorem 20.22. This motivates the following somewhat informal

Guess: (1) *Let M be a compact oriented boundaryless simply connected 4-manifold. Let $\omega \in \mathcal{H}^2(M; \mathbb{Z})$ be a characteristic element of its intersection form represented by an embedded oriented surface $F \subset M$. Then one expects a formula of the type*

$$\left[\frac{\sigma(M) - \omega \sqcup \omega}{8} \right]_{(2)} = \alpha(F)$$

where $\alpha(F) \in \mathbb{Z}/2\mathbb{Z}$ represents an obstruction to surgery F "within M " to get an embedded S^2 . Moreover, having in mind Pontryagin's computation of π_2^∞ depicted in Section 17.4.3 (recall also the study of immersions of surfaces in 3-manifolds in Section 19.8), it is predictable that $\alpha(F)$ is the Arf invariant of some quadratic enhancement of $\mathcal{H}_1(F; \mathbb{Z}/2\mathbb{Z})$ (see Section 15.6) associated to the embedding of F in M .

(2) *Assuming the isomorphism $\sigma : \Omega_4 \rightarrow \mathbb{Z}$, in contrast with the above derivation of Theorem 20.21 from the homotopic result $\pi_3^\infty = \mathbb{Z}/24\mathbb{Z}$, the definition of $\alpha(F)$ as well as the proof of the congruence should be geometric and possibly elementary.*

Accordingly with Freedman-Kirby [FK] (1978), the realization therein of the above guess is derived, considerably different in details, from one outlined by Casson in 1974 (unpublished). Accordingly to the historical appendix by Kharlamov and Viro in [GM], Rohlin announced such a formula at the Moskow IMC 1966 but only in a paper of 1972 he used it to solve a conjecture by Gudkov concerning

Hilbert’s 16th problem about the configuration of ovals of planar even degree real algebraic curves. The study of this problem by means of a 4-manifold obtained as a branched covering of $\mathbf{P}^2(\mathbb{C})$ ramified along a given non singular real algebraic curve in $\mathbf{P}^2(\mathbb{R}) \subset \mathbf{P}^2(\mathbb{C})$ was introduced by Arnol’d [A3] (1971). The basic congruences mod(8) already imply non trivial prohibitions for the oval configuration; the finer formula as in the above guess implies stronger prohibitions. All this holds under weaker hypotheses relaxing the fact that M is simply connected; for example $\Omega_1(M) = 0$ suffices to define the quadratic enhancement by using “membranes” (see below) and we can even avoid the use of membranes by means of spin structures (see [Kirby]). However, we will keep M to be simply connected and follow the treatment of Matsumoto [Mat] given in a paper available in [GM]; it is the simplest one as it is readily accessible by means of the tools developed in the present text.

20.6.1. Quadratic enhancement for characteristic surfaces. In this section M will be a compact oriented connected smooth 4-manifold such that $\Omega_1(M) = 0$ (this holds in particular if M is simply connected) and $F \subset M$ an orientable surface. Let c be a simple connected smooth circle on F . As $\Omega_1(M) = 0$ and using transversality, there exists a smooth map $f : P \rightarrow M$ such that:

- P is an oriented compact surface with one boundary component;
- $f(\partial P) = c$;
- The restriction of f to a collar C of ∂P in P is an embedding;
- $f(C \setminus \partial P) \subset M \setminus F$ and $f(C)$ is normal to F along c ;
- f is a generic immersion of P in M ;
- $f|(P \setminus \partial P)$ is transverse to F .

Such a map f is said a *membrane* along c . We simply write P instead of (P, f) . If M is simply connected we can also assume that P is a 2-disk, but this is not so important at this point. For simplicity let us identify c with ∂P . The pull-back of $T(M)$ on P splits as

$$f^*T(M) = T(P) \oplus \nu(f)$$

where $\nu(f)$ is said the *normal bundle of the membrane* and is an oriented bundle of rank 2. As P retracts to a wedge of a finite number of S^1 (to one point if P is a disk), then $\nu(f)$ is isomorphic to a product bundle. Let us fix a global trivialization τ . This induces a trivialization of the restriction $\nu(f)|_c$. Two trivializations of $\nu(f)$ differ by a map $g : P \rightarrow SO(2)$. The restriction $g|_c$ represents 0 in $\Omega_1(SO(2))$, hence it is homotopically trivial (Section 13.3). Then the restricted trivialization τ_c does not depend on the choice of τ . The normal bundle ν_c of c in F define a rank-1 orientable sub-bundle of $\nu(f)|_c$. Then denote by $n(P)$ the *number of full twists made by ν_c with respect to τ_c , moving along c in the direction given by its orientation as ∂P* . It is not hard to check that $[n(p)]_{(2)} \in \mathbb{Z}/2\mathbb{Z}$ does not depend on the choice of the orientation of P .

Let now $a \in \mathcal{H}_1(F; \mathbb{Z}/2\mathbb{Z})$. We know (Lemma 15.3) that $a = [c]$ for some simple smooth circle c on F . Given a membrane P along c , set

$$q_F(c, P) = [n(P)]_{(2)} + [P \bullet F]_{(2)} \in \mathbb{Z}/2\mathbb{Z}$$

where $P \bullet F$ is in fact the intersection number between $\text{Int}(P)$ and F . We have

PROPOSITION 20.23. *Let $F \subset M$ be an oriented characteristic surface of M , that is $\omega = [F] \in \mathcal{H}^2(M; \mathbb{Z})$ is a characteristic element of the intersection form of M . Then:*

- (1) *For every simple smooth circle c on F , $q_F(c) := q_F(c, P)$ does not depend on the choice of the membrane P along c .*

- (2) For every $a \in \mathcal{H}_1(F; \mathbb{Z}/2\mathbb{Z})$, for every simple smooth circle c representing a ($a = [c]$), then $q_F(a) := q_F(c)$ does not depend on the choice of the representative c .
- (3) The function $q_F : \mathcal{H}_1(F; \mathbb{Z}/2\mathbb{Z}) \rightarrow \mathbb{Z}/2\mathbb{Z}$ defined so far is a quadratic enhancement of the intersection form on $\mathcal{H}_1(F; \mathbb{Z}/2\mathbb{Z})$.

Proof : (1) Let P and P' be two membranes along c . Up to “spinning” P' along c , we can assume that P and P' glue along the common boundary c in such a way that: (i) $\Sigma = P \cup P'$ is a boundaryless surface generically immersed into M ; (ii) a tubular neighbourhood of c in Σ is an embedded annulus normal to F , made by two collars C and C' in P and P' respectively, opposite to each other. The membranes P and P' determine respective trivializations τ_c and τ'_c which induce opposite orientations on the fibres of the bundle. The difference between $-\tau'_c$ and τ_c along c is encoded by an element $d \in \pi_1(SO(2)) = \mathbb{Z}$. One verifies that

$$\Sigma \bullet \Sigma = d - 2P \bullet P' = d \pmod{2}$$

$$\Sigma \bullet F = P \bullet F + P' \bullet F \pmod{2}$$

(recall that the self-intersection of c in F $c \bullet c = 0$ because F is orientable). As F is characteristic, then

$$\Sigma \bullet \Sigma = \Sigma \bullet F \pmod{2}$$

hence

$$d = P \bullet F + P' \bullet F \pmod{2} .$$

On the other hand,

$$n(P') = n(P) + d \pmod{2} .$$

By combining these relations we eventually get

$$n(P) + P \bullet F = n(P') + P' \bullet F \pmod{2}$$

as desired. Item (1) is proved.

To achieve (2) (3) we can implement the method illustrated at the end of Section quadratic. We have defined a function which associate $q(c) \in \mathbb{Z}/2\mathbb{Z}$ to every simple smooth circle on F . It is clear that $q(c) = 0$ if c is the boundary of a 2-disk embedded in F . We extend additively this function to every not necessarily connected simple curve $c = c_1 \amalg \dots \amalg c_k$ on F . If γ is now a curve generically immersed in F with a number say $r(\gamma) \geq 0$ of normal crossings, every crossing can be simplified in two ways. Let us call a *state* s of γ a system of simplifications at every crossing. Performing these simplifications we get a simple curve c_s . Set

$$q_F(\gamma, s) = q_F(c_s) + [2r(\gamma)]_{(2)} .$$

Then it is enough to prove that $q_F(\gamma) := q_F(\gamma, s)$ does not depend on the choice of the state s . Arguing by induction of $r(\gamma)$, we localize the question at one crossing. If s and s' differ just at one crossing, then we can use membranes P and P' along the components of c_s and $c_{s'}$ which only differ locally at the crossing. By a direct computation we can compute $q_F(\gamma, s)$ and $q_F(\gamma, s')$ by using P and P' getting the desired result. \square

For the definition of the Arf invariant of q_F we refer to Section 15.6. In the next proposition we show that the Arf invariant of q_F only depends on the characteristic element $\omega = [F] \in \mathcal{H}^2(M; \mathbb{Z})$.

PROPOSITION 20.24. *Let $F, F' \subset M$ be oriented characteristic surfaces of M representing the same characteristic element ω of the intersection form of M . Then $\text{Arf}(q_F) = \text{Arf}(q_{F'})$, so that $\alpha(\omega) := \text{Arf}(q_F) \in \mathbb{Z}/2\mathbb{Z}$ is well defined.*

Proof: We repeat an embedded bordism argument already employed in Sections 17.4.3, 19.8.1. We know that there is an orientable 3-dimensional triad (W, F, F') properly embedded into the triad $(M \times [0, 1], M \times \{0\}, M \times \{1\})$ and we can assume that the restriction to (W, F, F') of the projection onto $[0, 1]$ is a Morse function. Consider the corresponding handle decomposition of (W, F, F') and the successive surgeries which produce F' from F . It is immediate that either attaching a 0-handle or attaching a 1-handle to different boundary connected components does not change the value of Arf. By attaching a 1-handle to a same connected component, the boundary is modified by an embedded connected sum with a copy of $T = S^1 \times S^1$; we realize that there is a basis l, m of $\mathcal{H}_1(T; \mathbb{Z}/2\mathbb{Z})$ such that the intersection form is represented by the standard matrix \mathbf{H} and m is the co-core of the handle, so that $q_T(m) = 0$. It follows that $\text{Arf}(q_T) = 0$, so that the total Arf does not change also in this case. Finally we consider the dual handle decomposition to rule out also 2 and 3-handles. □

20.6.2. A digression in classical knot theory. Let us recall a few facts of classical knot theory (see for instance [Kau], [Rolf]) that we will use below in the proof of the main result. Let K be a knot in $S^3 = \partial D^4$ considered up to ambient isotopy. Every oriented proper surface $(S, \partial S) \subset (D^4, S^3)$ such that $\partial S = K$ is “characteristic” for $\mathcal{H}^2(D^4, S^3; \mathbb{Z}) = 0$. So by a similar construction as above we can define a quadratic form $q_S : \mathcal{H}_1(S; \mathbb{Z}/2\mathbb{Z}) \rightarrow \mathbb{Z}/2\mathbb{Z}$ whose Arf invariant $\alpha(q_S) \in \mathbb{Z}/2\mathbb{Z}$ eventually depends only on the knot K so that the *Arf invariant of the knot* $\text{Arf}(K) := \alpha(q_S)$ is well defined. It can be computed by means of any oriented planar diagram \mathcal{D} of K as follows. We can use as S the surface obtained by pushing in D^4 the Seifert surface of K in S^3 constructed by means of the Seifert algorithm via the oriented simplification of the normal crossings of \mathcal{D} . If \mathcal{D}' is a knot diagram which differs from \mathcal{D} just by the over/under branches at one crossing, denote by K' the corresponding knot. Performing the simplification at the given crossing of \mathcal{D} (or of \mathcal{D}' , the result is the same) we get a diagram \mathcal{D}'' of a link with two oriented components K_1 and K_2 . Then one realizes that the following relation holds involving the linking number of K_1 and K_2 :

$$\text{Arf}(K) = \text{Arf}(K') + [L(K_1, K_2)]_{(2)} \in \mathbb{Z}/2\mathbb{Z} .$$

The linking number mod (2) can be easily computed by means of the diagram \mathcal{D}'' : the number c of crossings of \mathcal{D}'' whose local branches do not belong to a same constituent knot is even and $[L(K_1, K_2)]_{(2)} = [c/2]_{(2)}$. Moreover, it is well known that one gets a diagram \mathcal{D}_0 for the unknot K_0 by switching some crossings of \mathcal{D} ; clearly $\text{Arf}(K_0) = 0$; then the above relation allows to compute inductively $\text{Arf}(K)$ starting from \mathcal{D} .

Let $T \subset \mathbb{R}^3$ be the standard torus obtained by rotation of the planar circle $\{x = 0, (y - 2)^2 + z^2 = 1\}$ around the z -axis. For every couple (p, q) of coprime integers, the *torus knot* $K(p, q)$ is traced on T turning p times in the direction of the standard longitude of T , q times in the direction of the meridian. By projection onto the (x, y) coordinate plane, we get a standard diagram $\mathcal{D}(p, q)$ of $K(p, q)$. We will be interested to the case $K(s, s - 1)$, where $s > 1$ is odd (so that $(1 - s^2) \equiv 0 \pmod{8}$). It is known in knot theory (for example by applying the above method to the diagram $\mathcal{D}(s, s - 1)$) that

$$\text{Arf}(K(s, s - 1)) = \left[\frac{1 - s^2}{8} \right]_{(2)} .$$

20.6.3. The main results. We can state now the main result of this section.

THEOREM 20.25. *Let M be a compact oriented boundaryless simply connected 4-manifold. Let $\omega \in \mathcal{H}^2(M; \mathbb{Z})$ be a characteristic element of the intersection form*

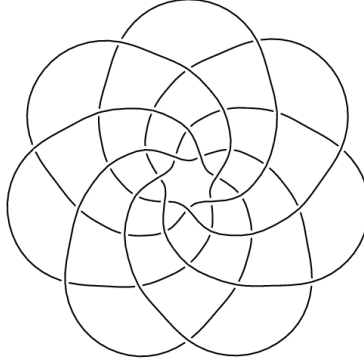
FIGURE 2. A standard diagram of $K(7,6)$.

of M . Then

$$\left[\frac{\sigma(M) - \omega \sqcup \omega}{8} \right]_{(2)} = \alpha(\omega) .$$

Proof : The proof is based on the classification up to odd stabilization. First note that if $M = M_1 \# M_2$ is the connected sum of two simply connected manifolds, then a characteristic element ω of M is the sum $\omega = \omega_1 + \omega_2$ of characteristic elements of M_1 and M_2 respectively. So if the theorem holds for two members of the triple (M, ω) , (M_1, ω_1) , (M_2, ω_2) , then it holds also for the third. By Theorem 20.15 we have that

$$M \# (k\mathcal{P} \# h\mathcal{Q}) = m\mathcal{P} \# n\mathcal{Q}$$

for some $k, h, m, n \in \mathbb{N}$. Then by applying inductively the above remark, it is enough to prove the theorem for \mathcal{P} and \mathcal{Q} . If $\mathbf{P}^1(\mathbb{C}) \subset \mathcal{P}$ is a complex line, then every characteristic element of \mathcal{P} is of the form $\omega = s[\mathbf{P}^1(\mathbb{C})]$, where s is an odd integer; to our aims it is not restrictive to assume that $s \geq 1$. The theorem clearly holds for $s = 1$, so let us assume $s > 1$. Then $\omega = [F]$ where F is any non singular complex projective curve in \mathcal{P} defined as the zero set of a homogeneous polynomial of degree s in the homogeneous complex coordinates (z_1, z_2, z_3) on \mathcal{P} . One can prove indeed (by using the fibration theorem 5.14) that all these curves are isotopic to each other but this is not so important for the present discussion. Let us consider the family of projective curves

$$F_\epsilon = \{z_1^s + z_2^{s-1}z_3 - \epsilon z_3^s = 0\}$$

where $\epsilon \in \mathbb{R}$, $\epsilon \geq 0$. For $\epsilon = 0$, F_0 has one isolated singularity at the point $x_0 = (0, 0, 1)$ and in the affine coordinates such that $z_3 \neq 0$, it is defined by the equation $x^s + y^{s-1} = 0$. The best reference for the study of such isolated singularities of complex planar curves is celebrated Milnor's book [M6]. Our case is particularly simple and the following facts are verified. There is a small round 4-disk D around $x_0 = (0, 0)$ in such affine chart, such that:

- (1) $S^3 = \partial D$ is tranverse to F_0 and $K := F_0 \cap S^3$ is a torus knot $K(s, s-1)$.
- (2) The pair $(D, F_0 \cap D)$ is homeomorphic to the pair (D, cK) where cK denotes the cone with base K and centre at x_0 .
- (3) $F_0 \cap (\mathcal{P} \setminus \text{Int}(D))$ is a smooth properly embedded 2-disk. Hence F_0 is homeomorphic to S^2 .

If $\epsilon > 0$ is small enough, then

- (i) F_ϵ is non singular.
- (ii) $F_\epsilon \cap S^3$ is an isotopic copy of $K(s, s-1)$ and $F_\epsilon \cap D$ is properly embedded.
- (iii) $F_\epsilon \cap (\mathcal{P} \setminus \text{Int}(D))$ is a smooth properly embedded 2-disk.

Then it is clear that

$$\alpha(\omega) = \text{Arf}(q_{F_c}) = \text{Arf}(K(s, s - 1)) = \left[\frac{1 - s^2}{8} \right]_{(2)} = \left[\frac{\sigma(\mathcal{P}) - \omega \sqcup \omega}{8} \right]_{(2)}$$

and this achieves the case $M = \mathcal{P}$. By taking into account the change of orientation, the same argument holds as well for $M = \mathcal{Q}$ and the proof is complete. \square

20.6.4. On an extension to non orientable characteristic surfaces. We have mentioned a 4-dimensional approach to Hilbert’s 16th problem where the congruences mod(16) give non trivial information. In this setting it is quite current to deal with *non orientable characteristic surfaces* that is representing the reduction mod(2) of any characteristic element of the intersection form of some 4 manifold M . This strongly motivates the search for a further generalization of Theorem 20.25. We limit to state it.

Let $F \subset M$ be a not necessarily orientable characteristic surface. Assume that $\Omega_1(M) = 0$. Similarly to Section 19.8 and using membranes as in the above definition of q_F , we can define a quadratic enhancement

$$\hat{q}_F : \mathcal{H}_1(F; \mathbb{Z}/2\mathbb{Z}) \rightarrow \mathbb{Z}/4\mathbb{Z}$$

of the intersection form by setting

$$\hat{q}_F([c]) = \hat{q}_F(c, P) = [\hat{n}(P)]_{(4)} + 2 \cdot ([P \bullet F]_{(2)} + c \bullet c) \in \mathbb{Z}/4\mathbb{Z}$$

where $\hat{n}(P)$ is the number of *half-twists* made by ν_c with respect to τ_c , moving along c . The fact that is well defined is a bit more complicated but not so much.

Similarly to the discussion made to define the integer Euler-Poincaré characteristic also for non orientable manifolds, we can define geometrically the self-intersection number $F \bullet F \in \mathbb{Z}$ by identifying F with the zero section of its normal bundle in the oriented manifold M and fixing arbitrary compatible local orientations of F and F' at every point of $F \pitchfork F'$, F' being a section transverse to F . By usual arguments this number does not depend on the arbitrary choices made to compute it. Recall the Arf-Brown invariant of \hat{q}_F defined in Section 15.6. Here we denote it by $\hat{\alpha}(F) \in \mathbb{Z}/8\mathbb{Z}$. Recall that the multiplication by 2 determines injective homomorphisms $\mathbb{Z}/2\mathbb{Z} \rightarrow \mathbb{Z}/4\mathbb{Z} \rightarrow \mathbb{Z}/8\mathbb{Z} \rightarrow \mathbb{Z}/16\mathbb{Z}$. Finally we can state:

THEOREM 20.26. *Let M be a compact oriented boundaryless simply connected 4-manifold. Let $F \subset M$ be a possibly non orientable surface which represents the reduction mod(2) of any characteristic element ω of the intersection form of M . Then*

$$[\sigma(M) - F \bullet F]_{(16)} = 2 \cdot \hat{\alpha}(F) .$$

If F is oriented we recover Theorem 20.25, because $F \bullet F = \omega \sqcup \omega$, $\hat{q}_F = 2 \cdot q_F$, $\hat{\alpha}(F) = 4 \cdot \alpha(\omega)$.

Theorem 20.26 is due to Guillou-Marin [GM]. There are several difficulties to overcome. When F is non orientable, $F \bullet F \in \mathbb{Z}$ cannot be identified with the intersection number of any bordism classes of M . So it is not clear how to reformulate Proposition 20.24. The reduction mod(2), say $\omega_{(2)}$, of any characteristic number ω does not depend on the choice of ω . So we should rather prove that $[F \bullet F + 2 \cdot \hat{\alpha}(F)]_{(16)}$ does not depend on the choice of the (possibly non orientable) surface F representing $\omega_{(2)}$. Note also that dealing with non orientable surfaces, the embedded bordism argument used in the proof of Proposition 20.24 is not immediately available (recall Remark 13.11). In the already cited paper [Mat], Matsumoto gives another proof which by an inductive argument reduces the general statement to forms Theorem 20.25. In both proofs there are two other basic cases besides \mathcal{P} and \mathcal{Q} , that is S^4 with suitably embedded real projective spaces as characteristic surface.

20.7. On the topological classification of smooth 4-manifolds

From Rohlin's theorem (1952) to Donaldson's work in 1982 [Do], no further prohibitions to the realizability of unimodular forms by boundaryless smooth 4-manifolds appeared. On the other hand Wall's Theorem 20.18 was the strongest one about the extent which the intersection form determines the differential topology of a boundaryless 4-manifold. At the beginning of the 80's two parallel new waves have revolutionated the subject. Since Donaldson's work, the introduction of new methods derived from gauge theory, of differential-geometric/analytic nature and strongly influenced by ideas of theoretical physics, have produced amazing new prohibitions and powerful smooth invariants distinguishing homeomorphic but non diffeomorphic smooth 4-manifolds. Let us recall a few new prohibitions.

(Donaldson 1982 [Do]) *If the intersection form of a simply connected, boundaryless smooth 4-manifold is definite then it is diagonalizable, that is of the form $k\mathbf{U}_\epsilon$.*

Donaldson's result means that the arithmetic complication of definite forms does not concern the intersection forms of smooth 4-manifolds; hence the problem of four dimensional smooth realizability is reduced to the indefinite and even case. To this respect we recall:

(Furuta 2001 [Fu]) *If the intersection form of a simply connected, boundaryless smooth 4-manifold is indefinite and even, that is of the type $2h\mathbf{E}_8 \perp a\mathbf{H}$, then $a \geq 2|h| + 1$.*

The following still is an open conjecture.

The so called "11/8" Conjecture: *If the intersection form of a simply connected, boundaryless smooth 4-manifold is indefinite and even, that is of the type $2h\mathbf{E}_8 \perp a\mathbf{H}$, then $a \geq 3|h|$.*

If the conjecture holds true, then the rank must be at least 11/8 times $|\sigma|$. Furuta theorem means that the rank is at least 10/8 times $|\sigma|$. If the form is indefinite and even we may assume that it is of nonpositive signature by changing orientations if necessary, in which case $h \leq 0$. If $a \geq 3|h|$, then the form can be realized by means of $|h|K \# (a - 3|h|)(S^2 \times S^2)$, where K is the Kummer complex surface of Example 20.11. Hence a confirmation of the conjecture would achieve the realizability problem.

The other wave had a somewhat more conservative motivation. It was clear at least since Rohlin's 'mistake', that there were in general actual obstructions in order to apply the Whitney trick in dimension 4; nevertheless one wondered if such a 'technical' difficulty could be circumvented in some way in order to prove the 5-dimensional h -cobordism theorem. For example in Wall's theorem 20.19 this is done by paying the price of performing even stabilizations. In this vein, in 73-74 A. Casson introduced so called "flexible handles" later currently called "Casson handles" (see Lecture I in the second part of [GM]). Let M be a boundaryless simply connected 4-manifold and let $\alpha, \beta \in \mathcal{H}_2(M; \mathbb{Z})$ such that $\alpha \bullet \alpha = \beta \bullet \beta = 0$, $\alpha \bullet \beta = 1$. Then, by means of a certain 'infinite construction', he produced an open set V of M such that

- V has the proper homotopy type of $S^2 \times S^2 \setminus \{pt\}$;
- $\mathcal{H}_2(V; \mathbb{Z})$ carries the submodule of $\mathcal{H}_2(M; \mathbb{Z})$ generated by α and β

Moreover, he argued (Lecture III of the second part of [GM]) that

If flexible handles V are diffeomorphic to the true $S^2 \times S^2 \setminus \{pt\}$, then we could carry out the Whitney process and cancel handles to trivialize five dimensional simply connected h -cobordisms.

More information about the flexible handles (at least about its 'end') would be also of main importance with respect to the realizability problem:

- If such a flexible handle V would be diffeomorphic to the true $S^2 \times S^2 \setminus \{pt\}$, then we could split $M = M' \# (S^2 \times S^2)$ where M' is simply connected and passing from W to W' we have surgered out a factor \mathbf{H} of the intersection form of M .

- If V is diffeomorphic to $N \setminus \{pt\}$ where N is a compact boundaryless 4-manifold, then $M = M' \# N$ where N has the homotopy type of $S^2 \times S^2$ and again carries α and β ; so M' has the same properties as above.

- If the end of V coincides with the end of an open contractible manifold V^* , then by replacing V with V^* we get again W' with α and β killed.

Notice that before Donaldson's result, there were not known obstructions in order that the arithmetic splitting of an indefinite and even form $2h\mathbf{E}_8 \perp a\mathbf{H}$ of some simply connected 4-manifold M could be realized by a splitting $M' \# a(S^2 \times S^2)$. After Donaldson we know that the above underlying hope was too optimistic, nevertheless the main achievement of [Fr] (1982) was that

A flexible handle is a 'true' $S^2 \times S^2 \setminus \{pt\}$, provided one works in the more flexible setting of almost smooth 4-manifolds.

A topological manifold N is *almost smooth* if $N \setminus \{pt\}$ has a smooth structure (which in general cannot be extended over the whole N). Remarkably, more or less at the same time it was proved in [Q]:

Every boundaryless simply connected topological 4-manifold is almost smooth.

This opens the way (via the solution of other hard technical issues) for a complete classification of topological simply connected 4-manifolds, which includes the fact that *every* unimodular symmetric form can be realized as the intersection form of a boundaryless simply connected almost smooth 4-manifolds. Here we limit to state a few corollaries in our favourite smooth setting.

(1) **Topological five dimensional h -cobordism:** *Every smooth simply connected 5-dimensional h -cobordism (W, M_0, M_1) is homeomorphic to the product $M_0 \times [0, 1]$. In particular M_0 and M_1 are homeomorphic to each other.*

(2) **A classification of smooth 4-manifolds up to homomorphism:** *Two smooth simply connected boundaryless 4-manifolds are homeomorphic if and only if they have isometric intersection forms.*

The new gauge theoretical prohibitions and smooth invariants, together with the above topological classifications, lead to a dramatic failure of the *smooth* five dimensional h -cobordism theorem and to the existence of a plenty of non diffeomorphic smooth structures on certain topological 4-manifolds. In particular we recall that the Kummer complex surface of Example 20.11 admits countably many non diffeomorphic smooth structures [FS]. Finally we recall that the classification of topological 4-manifolds includes the solution of the four dimensional *topological* Poincaré conjecture: *Every boundaryless topological 4-manifold which is homotopically equivalent to S^4 is homeomorphic to S^4 .* It is not known if every *smooth* boundaryless 4-manifold which is homotopically equivalent to S^4 is *diffeomorphic* to S^4 . This smooth four dimensional Poincaré conjecture presumably is the main basic open question about smooth 4-manifolds.

Appendix: baby categories

Along the text we make some (very moderate indeed) use of the language of categories. We collect in this appendix the few necessary notions.

A *category* \mathbf{C} consists of three things:

- (1) A class of *objects* X ;
- (2) For every ordered pair of objects (X, Y) , a set $\text{Hom}(X, Y)$ of *morphisms* (also called *arrows*) $f : X \mapsto Y$;
- (3) For every ordered triple (X, Y, Z) of objects, a *composition function of arrows*

$$\circ : \text{Hom}(X, Y) \times \text{Hom}(Y, Z) \rightarrow \text{Hom}(X, Z), (f, g) \rightarrow g \circ f .$$

We require that the following properties are satisfied:

- (1) (*Associativity*) Whenever the involved compositions make sense, we have $h \circ (g \circ f) = (h \circ g) \circ f$;
- (2) (*Existence of the identity*) For every object X , there is a (necessarily unique) arrow $1_X \in \text{Hom}(X, X)$ such that $1_X \circ f = f$, $g \circ 1_X = g$, whenever the compositions make sense.

A morphism $f \in \text{Hom}(X, Y)$ is an *equivalence* in the category \mathbf{C} if there exists a (necessarily unique) morphism $g \in \text{Hom}(Y, X)$ such that $f \circ g = 1_X$ and $g \circ f = 1_Y$.

A fundamental example is the category of sets, denoted by **SET**, which has as objects the class of all sets, while $\text{Hom}(X, Y)$ consists of the set of all maps from X to Y . 1_X is the identity map, while the equivalences are the bijective maps. We know a lot of sub-categories of **SET** obtained by specializing both objects and arrows: the categories of groups and group homomorphisms, of vector spaces (on a given scalar field) and linear maps, of topological spaces and continuous maps, of smooth manifolds and smooth maps The equivalences are the isomorphisms, the homomorphisms, the diffeomorphisms,

A single group G can be considered as a category with just G as unique object, while $\text{Hom}(G, G) \sim G$, by associating to every $h \in G$ the morphism by left multiplication by h , $L_h : G \rightarrow G, g \rightarrow hg$. In this category all morphisms are equivalences.

Not every category is a subcategory of **SET**. For example, starting from the category of topological spaces and continuous maps we can construct a new category with the same class of objects, and as arrows the *homotopy classes* of continuous maps from X to Y . The fact that associativity holds is left as an exercise.

If X is a path connected topological space, we can consider the category whose objects are the points of X and $\text{Hom}(x, y)$ consists of the homotopy classes $[\alpha]$ of paths in X connecting x and y . One can verify that every morphism in this category is an equivalence (we say that it is a *groupoid*).

Given two categories \mathbf{C} and \mathbf{D} , a *covariant functor* $\mathcal{F} : \mathbf{C} \Rightarrow \mathbf{D}$ from \mathbf{C} to \mathbf{D} assigns to every object X of \mathbf{C} , an object $\mathcal{F}(X)$ of \mathbf{D} , to every arrow $f \in \text{Hom}(X, Y)$ of \mathbf{C} , an arrow $\mathcal{F}(f) : \mathcal{F}(X) \mapsto \mathcal{F}(Y)$ of \mathbf{D} in such a way that the following properties are satisfied:

- (1) For every object X of \mathbf{C} , $\mathcal{F}(1_X) = 1_{\mathcal{F}(X)}$;
- (2) $\mathcal{F}(g \circ f) = \mathcal{F}(g) \circ \mathcal{F}(f)$, whenever the composition is defined.

A *contravariant functor* assigns to every $f \in \text{Hom}(X, Y)$, an arrow $\mathcal{F}(f) \in \text{Hom}(\mathcal{F}(Y), \mathcal{F}(X))$ in such a way that $\mathcal{F}(g \circ f) = \mathcal{F}(f) \circ \mathcal{F}(g)$. A basic example of contravariant functor is the functor from the category of vector spaces (on a given scalar field) to itself such that for every V , $\mathcal{F}(V) = V^*$ the dual space, and for every linear map $f : V \rightarrow W$, $\mathcal{F}(f) = f^t$ the transposed map of f , $f^t : W^* \rightarrow V^*$, $f^t(\phi) = \phi \circ f$.

Let \mathcal{F} and \mathcal{G} be two say covariant functors from \mathbf{C} to \mathbf{D} . A *natural transformation* T from \mathcal{F} to \mathcal{G} is a rule assigning to every object X of \mathbf{C} , a morphism $T_X : \mathcal{F}(X) \rightarrow \mathcal{G}(X)$ such that for every $f \in \text{Hom}(X, Y)$ of \mathbf{C} , $\mathcal{G}(f) \circ T_X = T_Y \circ \mathcal{F}(f)$. If for every X , T_X is an equivalence, then T is called a *natural equivalence of functors*.

For example a Δ -complex mentioned in the text can be abstractly defined as being a contravariant functor from the category Δ to the category **SET**, where Δ has as objects the ordered sets $\Delta^n = \{0, 1, \dots, n-1\}$, $n \in \mathbb{N}$, and as arrow the strictly increasing maps $\Delta^k \rightarrow \Delta^n$, $k \leq n$. Maps between Δ -complexes would be defined as natural transformations of the corresponding functors.

Bibliography

- [AG] F.D. Ancel, C.R. Guilbault, *An extension of Rourke's proof that $\Omega_3 = 0$ to non orientable manifolds*, Proc. AMS Vol. 115, 1, 283–291, 1992;
- [Ap] F. Apéry, *La surface de Boy*, Adv. Math., 61 (1986), 185–266;
- [A] V. I. Arnold, *Ordinary differential equations*, Springer Science and Business Media, 1992;
- [A2] Arnold, V.I., Gusein-Zade, S.M., Varchenko, Alexander N., *Singularities of Differentiable Maps, Volume 1*, Birkhäuser, 2012;
- [A3] V. I. Arnold, *On the arrangement of the ovals of real plane curves, involutions of 4-dimensional smooth manifolds and the arithmetic of integral quadratic forms*, Funktsionalni Anliz i ego Prilozheniya 5, 1971, 1–9;
- [AM] M. Artin, B. Mazur, *On periodic points*, Ann. of Math., 81, 82–99, 1965;
- [At] M. F. Atiyah, *K-Theory*, W. A. Benjamin, 1967.
- [BL] R. Benedetti, P. Lisca, *Framing 3-manifolds with bare hands*, arXiv:1806.04991 To appear on 'L'enseignement mathématique' (LEM);
- [BM] R. Benedetti, A. Marin, *Déchirure de variétés de dimension trois et la conjecture de Nash de rationalité en dimension trois*, Commentarii Math. Helvetici 67, (1993), 514–545;
- [BP] R. Benedetti, C. Petronio, *Branched standard spines of 3-manifolds*, Lectures Notes in Math. 1653, Springer, 1997;
- [BS] R. Benedetti, R. Silhol, *Spin and Pin^- structures, immersed and embedded surfaces and a result of Segre on real cubic surfaces*, Topology, Vol. 34, No.3, 651–678, 1995;
- [BR] R. Benedetti, J.-J. Risler, *Real algebraic and semi-algebraic sets*, Actualités Mathématiques, Hermann, Paris, 1990;
- [BCR] J. Bochnak, M. Coste, M-F. Roy, *Géométrie algébrique réelle*, Ergebnisse der Mathematik 3, 12, Springer, 1987;
- [BO] F. Bonahon, J-P. Otal *Scindements de Heegaard des espaces lenticulaires*, Annales scientifiques de l' E.N.S. 4e série, tome 16, no 3 (1983), p. 451–466;
- [BT] R. Bott, L.W. Tu, *Differential forms in algebraic topology*, Springer GTM 82, 1982;
- [B] R. Bott, *Lectures on $K(X)$* , W. A. Benjamin, 1969.
- [BH] S. Buoncristiano, D. Hacon, *An elementary geometric proof of two theorems of Thom*, Topology, Vol. 20, 97–99, 1981;
- [Bo] J.M. Boardman, *Singularities of differential maps*, Publ. Math. IHES 33, 1967;
- [Brod] E. J. Brody, *The topological classification of the lens spaces*, Annals of Mathematics, 2, 71 (1), 163–184, 1960;
- [Ce] J. Cerf, *Sur les difféomorphismes de la sphere de dimension trois*, LNM, Vol. 53, Springer 1968;
- [Ce2] J. Cerf, *La startification naturelle des espaces de fonctions defferentiables réelle et le thèorème de la pseudoisotopie*, Publ. Math. I.H.E.S. 39 (1970);
- [I] R.L. Cohen, *Immersion of manifolds*, Proc. Nat. Acad. Sci. USA, Vol. 79, 3390–3392, May 1982 Mathematics;
- [COM] A. Comessati, *Sulla connessione delle superficie razionali reali*, Annali di Mat. (3) 23, 1914;
- [Do] S.K. Donaldson, *An application of gauge theory to four dimensional topology*, J. Differential Geometry, 18 (1983), 279–315;
- [FR] R. Fenn, C. Rourke, *On Kirby's calculus of links*, Topology, Vol. 18, 1979, 1–15;
- [FS] R. Fintushel, R.Stern, *Knots, links, and 4-manifolds*, Invent. Math. 134, no. 2 (1998), 363?–400;
- [FM] A. T. Fomenko, S. V. Matveev, *Algorithmic and Computer Methods for Three-Manifolds*, Springer, MAIA, volume 425, 1997;
- [Fr] M.H. Freedman, *The topology of four dimensional manifolds*, J. Differential Geom. 17, no. 3, 357–453, 1982;
- [FK] M.H. Freedman, R. Kirby, *A geometric proof of Rochlin's theorem*, Proceedings of Symposia in Pure Mathematics, Vol 32, 1978;
- [Fu] M. Furuta, *Monopole equation and the 11/8 conjecture*, Mathematical Research Letters, 8, 279–291, 2001;

- [Ge] H. Geiges, *An Introduction to Contact Topology*, Cambridge University Press 2008;
- [G] R. Gini, *Cobordism of immersions of surfaces in non-orientable 3-manifolds*, *math. 104*, 49–69 (2001);
- [GM] L. Guillou, A. Marin, *A la recherche de la topologie perdue*, Progress in Mathematics 62, Birkhäuser, 1986;
- [GP] V. Guillemin, A. Pollack, *Differential Topology*, Prentice-Hall, 1974;
- [HT] S. Halperin, D. Toledo, *Stiefel-Whitney homology classes*, *Ann. of Math. (2)* 96 (1972) 511–525;
- [HH] J. Hass, J. Hughes, *Immersions of surfaces in 3-manifolds*, *Topology* 24, No. 1, 97–112, 1985;
- [Hatch] A. Hatcher, *Algebraic Topology*, Cambridge University Press, 2002, <http://www.math.cornell.edu/hatcher/AT/ATpage.html>;
- [HE] S. Hawking, G. Ellis, *The Large Scale Structure of Spacetime*, Cambridge University Press, 1973;
- [H] M.W. Hirsch, *Differential Topology*, Springer GTM, No. 33, 1997;
- [H2] M.W. Hirsch, *Immersions of Manifolds*, T.A.M.S., Vol. 93, 2, 242–276, 1959;
- [Hu] D. Husemoller, *Fibre bundles*, Springer (3rd ed.), 1994;
- [J] I. M. James, *The topology of Stiefel Manifolds*, Cambridge University Press, 1976;
- [Ka] S.J. Kaplan, *Constructing framed 4-manifolds with given almost framed boundaries*, T.A.M.S., Volume 254, October 1979, 237–263;
- [Kau] L. H. Kauffman, *On knots*, *Annals of Mathematics Studies*. 115; Princeton University, 1987;
- [KM] M. A. Kervaire, J.W. Milnor, *On 2-Spheres in 4-Manifolds*, *Proceedings of the National Academy of Sciences of the United States of America*, Vol. 47, No. 10 (Oct. 15, 1961), pp. 1651–1657;
- [Ki] H. King, *Approximating submanifolds of real projective spaces by varieties*, *Topology* 15 (1), 81–85, 1976;
- [Kirby] R. Kirby, *The Topology of 4-manifolds*, Springer LNM 1374, 1980;
- [Kirby2] R. Kirby, *A Calculus for Framed Links in S^3* , *Inventiones Mathematicae*, vol. 45 (1978), pp. 35–56;
- [Ko] J. Kollar, *Which are the simplest algebraic varieties?*, *Bulletin (New Series) of the A.M.S.*, Volume 38, Number 4, Pages 409–433, Article electronically published on June 12, 2001;
- [Ko2] J. Kollar, *The Nash conjecture for nonprojective threefolds*, *Contemp. Math.*, vol. 312, Amer. Math. Soc., Providence, RI, 2002, pp. 137–152;
- [KT] R. Kirby, L.R. Taylor, *Pin structures on low-dimensional manifolds*, in *Geometry of low-dimensional manifolds*, Vol.2, S.K. Donaldson and C.D. Thomas Eds, Cambridge University Press, (1989) 177–241;
- [Lick] W.B.R. Lickorish, *A representation of orientable combinatorial three-manifolds*, *Ann. of Math. (2)* 76, 531–540, 1962;
- [Lick2] W.B.R. Lickorish, *Homeomorphisms of non-orientable surfaces*, *Proc. Cambridge Philos. Soc.* 59 (1963), 307–317;
- [Ma] J.N. Mather, *Generic Projections*, *Annals of Mathematics*, Second Series, Vol. 98, No. 2 (Sep., 1973), pp. 226–245;
- [Ma2] J.N. Mather, *Stability of smooth mappings V: transversality*, *Advances in Math.* 4 (1970) 301–336;
- [Mart] B. Martelli, *An introduction to geometric topology*, ISBN 9781539580232, 2016;
- [Mart2] B. Martelli, *A finite set of local moves for Kirby calculus*, *Journal of Knot Theory and Its Ramifications* 21 (14), 2012;
- [Mat] Y. Matsumoto, *An elementary proof of Rochlin's signature theorem and its extension by Guillou and Marin*, pag. 119–139 in "A la recherche de la topologie perdue", Progress in Mathematics 62, Birkhäuser, 1986;
- [M1] J.W. Milnor, *Topology from the differentiable viewpoint*, The University Press of Virginia, Charlottesville, Second printing, 1969;
- [M2] J.W. Milnor, *Morse Theory*, Princeton University Press, No.51, 1963;
- [M3] J.W. Milnor, *Lectures on h-cobordism*, Princeton university press, 1965;
- [M4] J.W. Milnor, *On manifolds homeomorphic to the 7-sphere*, *Annals of Math.* 64, 399–405, 1956;
- [M5] J.W. Milnor, *On the Stiefel-Whitney numbers of complex manifolds and of spin manifolds*. *Topology* Vol. 3, pp. 223–230, 1965;
- [M6] J.W. Milnor, *Singular Points of Complex Hypersurfaces*, *Annals of Mathematics Studies*, Princeton University Press, 1968;
- [MH] J. W. Milnor, D. Husemoller, *Symmetric bilinear forms*, Springer 1973;
- [MK] J.W. Milnor, M. A. Kervaire, *Bernoulli numbers, homotopy groups and a theorem of Rohlin*, *Proceedings of the International Congress of Mathematicians*, Edinburgh, 1958;
- [MS] J.W. Milnor, J.D. Stasheff, *Characteristic Classes*, Princeton University Press, 1974;

- [Mu] J.R. Munkres, *Elementary differential topology*, Princeton University Press, 1961;
- [Mu2] J.R. Munkres, *Elements of algebraic topology*, Addison Wesley 1984;
- [Na] J. F. Nash, *Real algebraic manifolds*, Ann. of Math. 56 (3), 405–421, 1952;
- [Q] F.S. Quinn, *Ends of maps III*, J. Diff. Geometry 17, (1982), 503–521;
- [Pa] R.S. Palais, *Morse theory on Hilbert manifolds*, Topology, Vol. 2, 299–340, 1963;
- [Pi] U. Pinkall, *Regular Homotopy classes of immersed surfaces*, Topology 24, No.1, 421–434, 1985;
- [Pont] , L.S. Pontryagin, *Smooth manifolds and their applications in homotopy theory*, Amer. Math. Soc. Translations, ser. 2, II (1959),1–114 (translation from Trudy Inst. Steklov 45 (1955));
- [Rolf] D. Rolfsen, *Knots and Links*, Publish or Perish, MLS 7, 1976;
- [Rourke] C. Rourke, *A new proof that Ω_3 is zero*, J. London Math. Soc. (2) 31 (1985) 373–376;
- [RS] C.P. Rourke, B.J. Sanderson, *Introduction to Piecewise-Linear Topology*, Ergebnisse der Mathematik, Vol. 69, 1972, Springer;
- [Sc] A. Scorpan, *The wild world of 4-manifolds*, AMS, ISBN 0-8218-3749-4, 2005;
- [Seif] H. Seifert, *Algebraische approximation von Mannigfaltigkeiten*, Math. Z. 41, 1-17, 1936;
- [Se] J-P Serre, *Homologie singulière des espaces fibrés. Applications*, Annals of Mathematics, Second Series, 54 (3), 425–505 , 1951;
- [Sing] J. Singer, *Three-dimensional manifolds and their Heegaard diagrams*, Trans. Amer. Math. Soc. 35 (1933) 88–111;
- [Shi] M. Shiota, *Nash Manifolds*, Springer LNM 1269, 1987;
- [S0] S. Smale, *A classification of immersions of the two-sphere*, Trans. Amer. Math. Soc. 90, (1958), 281– 290;
- [S1] S. Smale, *Diffeomorphisms of the 2-sphere*, Proc. Amer. Math. Soc. 10, (1959), 621–626;
- [S2] S. Smale, *Generalized Poincaré ’s conjecture in dimensions greater than four*, Ann. of Math. (2) 74 (1961), 391–406.
- [Steen] N. Steenrod, *The topology of fibre bundles*, Princeton University Press, 1951;
- [Stief] E. Stiefel, *Richtungsfelder und Fernparallelismus in Mannigfaltigkeiten*, Comment. Math. Helv. 8, 3–51, 1936;
- [Stone] M. H. Stone, *The Generalized Weierstrass Approximation Theorem*, Mathematics Magazine, 21 (4): (1948) 167–184;
- [T] R. Thom, *Quelques propriétés globales des variétés différentiables*, Commenetarii Mathematici Helvetici, 28, 17–86, 1954;
- [To] H. Toda, *Composition methods in homotopy groups of spheres*, Annals of Mathematics Studies, 49, Princeton University Press, 1962;
- [Tog] A. Tognoli *Su una congettura di Nash*, Ann. Scuola Norm. Sup. Pisa 27, 167–185, 1973;
- [Tur] V.G. Turaev, *Quantum Invariants of Knots and 3-Manifolds*, De Gruyter Studies in Mathematics 18, 1994;
- [Wall] C.T.C. Wall, *Determination of cobordism ring*, Ann. of Math. (2) 72 (1960), 292–311;
- [Wall2] C.T.C. Wall, *Differential topology*, Cambridge Studies in Advanced Mathematics (156), 2016;
- [Wall3] C.T.C. Wall, *Diffeomorphism of 4-manifolds*, J. London Math.Soc. 39 (1964), 131–140;
- [Wall4] C.T.C. Wall, *On simply connected 4-manifolds*, J. London Math.Soc. 39 (1964), 141–149;
- [Wa] , A. H. Wallace, *Modifications and cobounding manifolds*, Can. J. Math., 12: 503?528, 1960;
- [Wa2] A. H. Wallace, *Algebraic approximation of manifolds*, Proc. London Math. Soc., 3(7), (1957);
- [Whit] H. Whitney, *A function non constant on a connected set of critical points*, Duke Math. J. 1, 514–517, 1935;
- [Whit2] H. Whitney, *The Self-Intersections of a Smooth n -Manifold in $2n$ -Space*, Annals of Math. (2) 45, 220–246, 1944 ;
- [Whit3] H. Whitney, *The Singularities of a Smooth n -Manifold in $(2n - 1)$ -Space*, Annals of Math. (2) 45, 247–293, 1944 ;